

AM-EN1611S113 SERIES

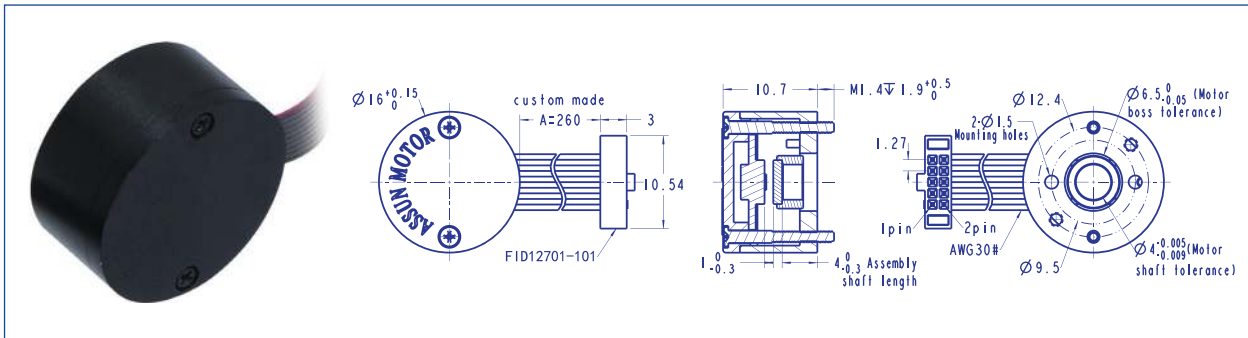

**Electromagnetic Encoder**

1) Basic parameters		2) Specification		3) Suitable for motor size		4) Pin definition	
Encoder type	absolute	Power Vcc	5V±5%	Suitable for shaft diameter	2.0;3.0;4.0	1. NC	2.Vcc
Multiple circles/bits	NC	Highest clock rate	10MHz	Suitable for shaft length	3.7~4.0	3. GND	4. NC
Angle/bit	16	Operating Temperature	-40~125°C	Suitable for boss diameter	6.45~6.5	5. SCL +	6. SCL -
protocol	SSI	Inertia	0.015g.cm <sup>2</sup>	Suitable for boss thickness	Max 1.0	7. NSL +	8. NSL -
Number of channels	3	Output Current, each channel	20mA(max)	Code wheel spacing	0.7~1.0	9. DO +	10. DO -
Differential signal	Yes	Weight	6.5 g	Other fixed size	Drawing		

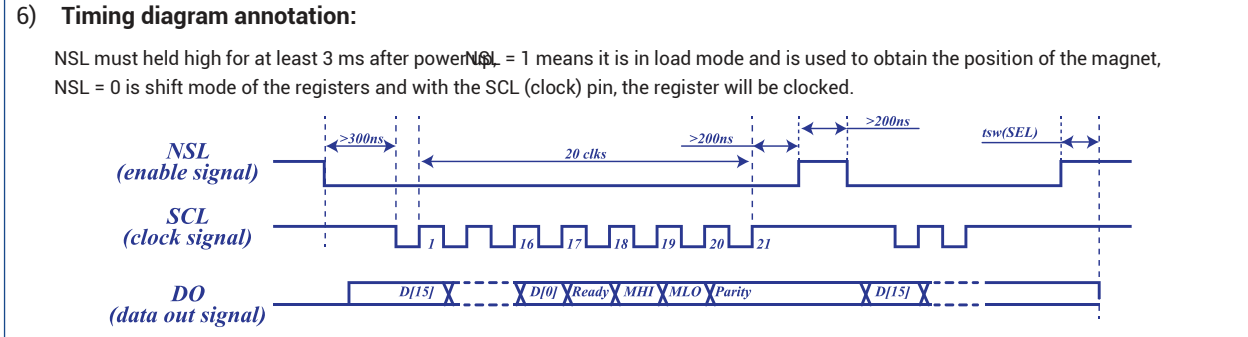
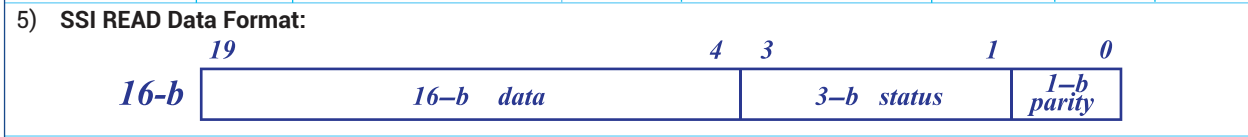

7) Recommended Combination

Total Length of Geared Motor System: L <sub>T</sub> =L1+L2+L3(=10.7mm)					
L1: 16GP	L1: 20GP	L2: BL16	L1: 20GP	L1: 24GP	L2: BL20
15.9	18.8	40.0	18.8	22.2	40.0
23.3	23.6		23.6	27.4	
27	28.4		28.4	32.6	
L1: 24GP	L1: 28GP	L2: BL24	L1: 28GP	L1: 28GP	L2: BL28
22.2	25.9	53.0	25.9	27.4	45.0
27.4	33.1		33.1	35.9	
32.6	40.3		40.3	44.4	

**AM-EN1611S\*\*\* Combination Scheme**

**Recommended Gearbox:**  
Planetary Gearbox:  
AM-16GP AM-28GP  
AM-20GP AM-32GP  
AM-24GP

**Recommended Motor:**  
AM-BL16\*\* AM-BL20\*\*\*  
AM-BL/D24\*\*  
AM-BL/D28\*\*

For more combination specs, visit Assun Motor website.

Remarks: Clients can choose gearbox and motor to match with this encoder. Some combinations are listed here for reference.

Please tell us if there is vibration in application. Client should pay attention to the integrity and reliability of the transmitted signal.

Download datasheet: <https://assunmotor.com/documents-download>