

AM-16HP Series

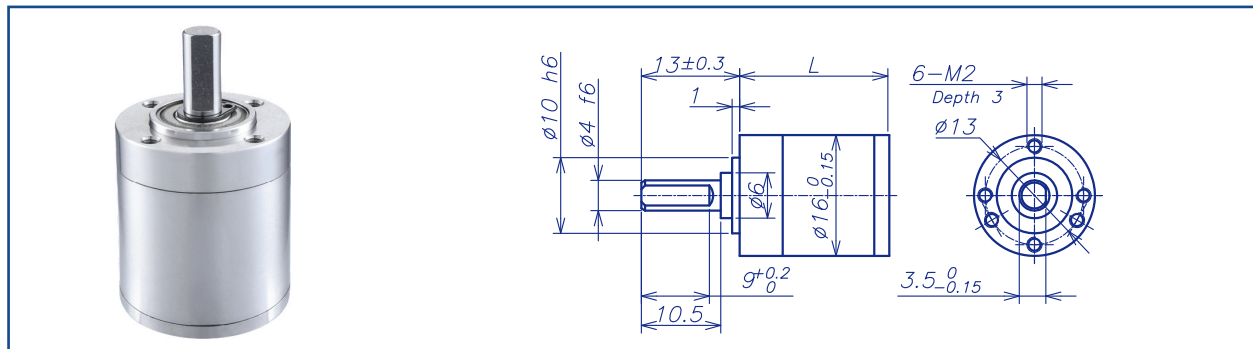

GEARBOX CHARACTER

Gear type	Straight teeth	Radial Play (6mm from flange)	max 0.1mm
Output shaft	Stainless steel hardened	Permissible force press fits	max. 100 N
Main gear	Alloy Steel hardened	Permissible axial load (dynamic)	max. 30N
Ring gear	Stainless steel hardened	Recommended input speed	16000RPM
Adapter plate	Stainless steel	Operating temperature range	-40°C ~ +100°C
Bearing AT output	Ball bearing	Operating humidity range	10-90%RH
Axial play	0-0.3	Number of stages	1 2 3 4
Directions	CW/CCW	Permissible load (6mm from flange)	30N 45N 70N 70N

GEARBOX DATA

Number of stage	1			2		3			4			
	Reduction ratio X:1	3.8	4.4	5.4	14	29	53	84	157	198	370	590
Reduction ratio absolute	15/4	57/13	27/5	225/16	729/25	3375/64	185193/2197	19683/125	50625/256	10556001/28561	531441/625	
				855/52		12825/208	4617/52		192375/832	263169/676		
				3249/169		48735/676	87723/845		731025/2704	6561/16		
				81/4	1539/65	1215/16	2187/20	41551/325	18225/64	5000211/10985	124659/260	
Motor shaft max. diameter (mm)	2	1.5		2	1.5				2			1.5
Gearbox length "L" (mm)	16.1			19.8		23.5			27.2			
Max. continuous torque (N.m)	0.1			0.5		0.8			0.9			
Max. intermittent torque (N.m)	0.12			0.7		1			1.08			
Average backlash no load	1.2°			1.4°		1.5°			1.5°			
Gearbox efficiency	90%			81%		73%			65%			
Max. mass inertia (g.cm ²)	0.04			0.04		0.04			0.04			
Gearbox weight approx (g)	25			30		35			40			
gearbox model	AM-16HPA-X			AM-16HPB-X		AM-16HPC-X			AM-16HPD-X			

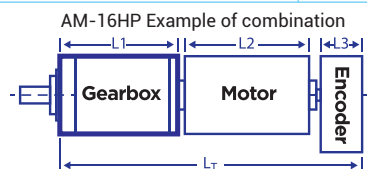

INPUT GEARBOX DATA

Modulus	0.3	
Press angle	20°	
Teeth number	10	13 16
Max gear hole "A"	1.5	2.0
Max motor shaft	1.5	2.0
Motor dimension "D"	6.0	

MOTOR DIMENSION

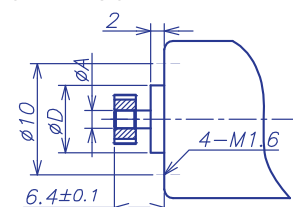

Recommend Motor:
Coreless Motor (w/E):
AM-CL1623MAN
AM-CL1626MAN
AM-CL1633MAN
AM-CL1643MAN

Recommend Encoder:
Suitable for Coreless Motor
Encoder S: AM-EN1611S***

Brushless Motor (w/E):
AM-BL1632AN
AM-BL1640AN

Suitable for Brushless Motor
Encoder S: AM-EN1611S***
Encoder T: AM-EN1612T***

GEARBOX MOTOR LENGTH "LT"

Gear motor length L_T	39.1	67.2	79.2
Gear box length L_1	16.1	23.5	27.2
Motor length L_2	23	33	40
Encoder length L_3	-	10.7	12

Download datasheet: <https://assunmotor.com/documents-download>

Visit Our Website and Online Shop at <https://assunmotor.com> Contact: info@assunmotor.com