

### Features

- Freq: DC-8.0GHz
- Insertion Loss: 2.0dB
- Attenuation Range:0.5~31.5dB
- Relative Phase Shift:±3°
- RMS: 0.7dB
- RF1/RF2 Stationary Wave: 1.3/1.3
- 50Ω Input/Output
- Die Size: 1.9×1.3×0.1mm<sup>3</sup>

### Functional Diagram

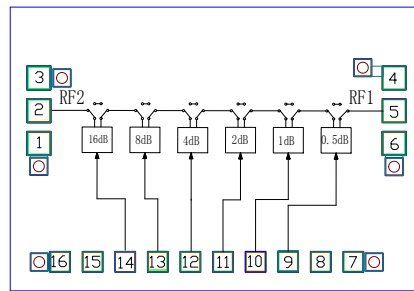

2.0dB and the additional phase shift is less than ± 3°. The logic control is 0V/+3.3V. A single Vcc bias of -5V is required. The Typical bias current is 7mA and the switch speed is less than 50ns.

The chip applies the on-chip metallization through-hole technology thus no need for additional grounding measures which makes it very easy and convenient to use; the backside of the chip is metallized, suitable for conductive adhesive bonding or eutectic mounting process..

### Generation Description

The MC14167 is a 6-bit, digital step attenuator working at DC-8.0 GHz with a typical insertion loss of

### Electrical Specification (T<sub>A</sub>=+25°C,50Ω system,0V/+3.3V Control (0V/+5VControl Compatible))

Parameter	Function	Min.	Typ.	Max.	Units
Frequency Range	Freq	DC	-	8.0	GHz
Insertion Loss	IL	-	2.0	-	dB
Attenuation Range	ΔIL	0.5~31.5			dB
Relative Phase Shift	ΔPhase	-	±3	-	°
Attenuation Accuracy	0.5	-	0.6	-	dB
	1.0	-	1.0	-	dB
	2.0	-	1.9	-	dB
	4.0	-	3.7	-	dB
	8.0	-	7.6	-	dB
	16.0	-	16.0	-	dB
RMS	-	-	0.7	-	dB
RF1 Stationary Wave	VSWR	-	1.3	-	-
RF2 Stationary Wave	VSWR	-	1.3	-	-

[1] The chips are 100% DC and RF tested.

### Typical Testing Characteristics

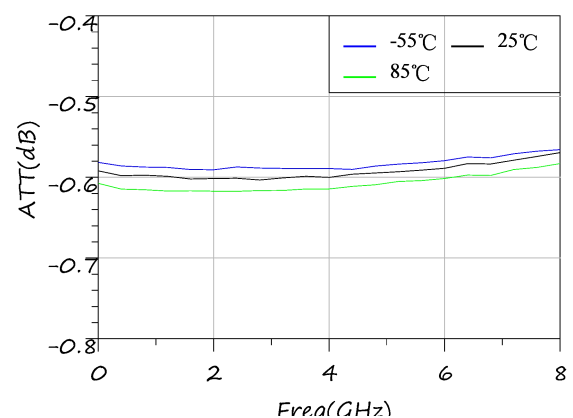
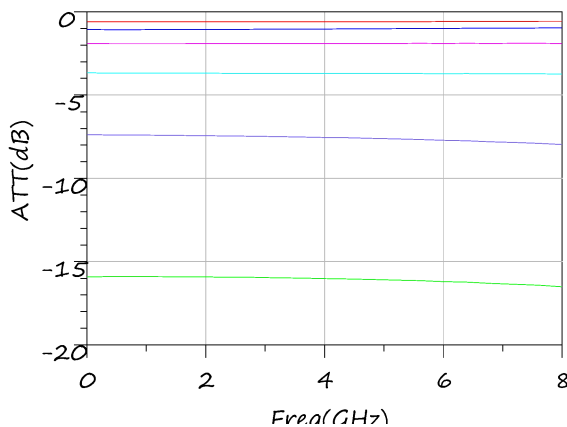

Normalized Attenuation & Frequency over Major Attenuation

0.5dB Attenuation State vs Frequency

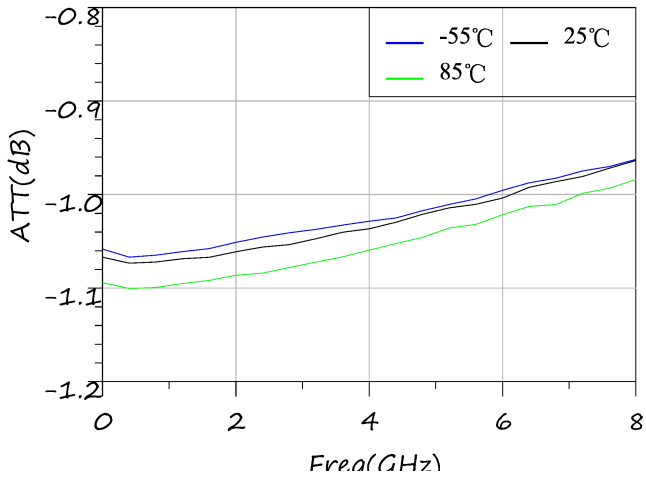

1dB Attenuation State vs Frequency

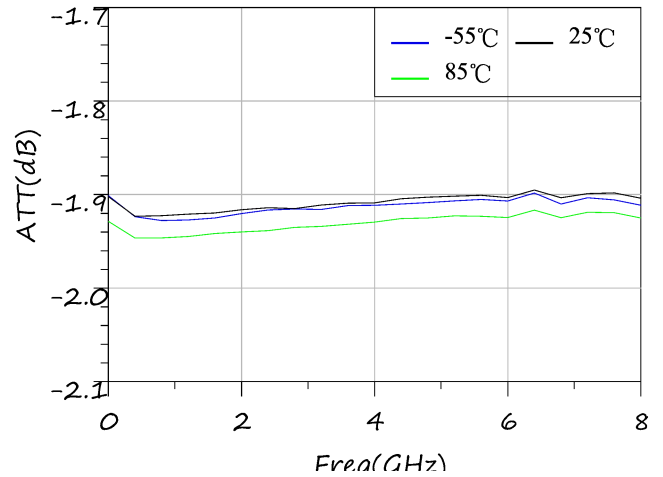

2dB Attenuation State vs Frequency

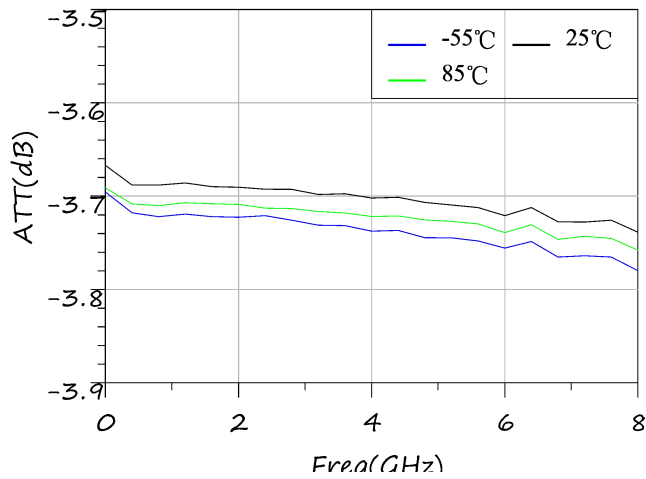

4dB Attenuation State vs Frequency

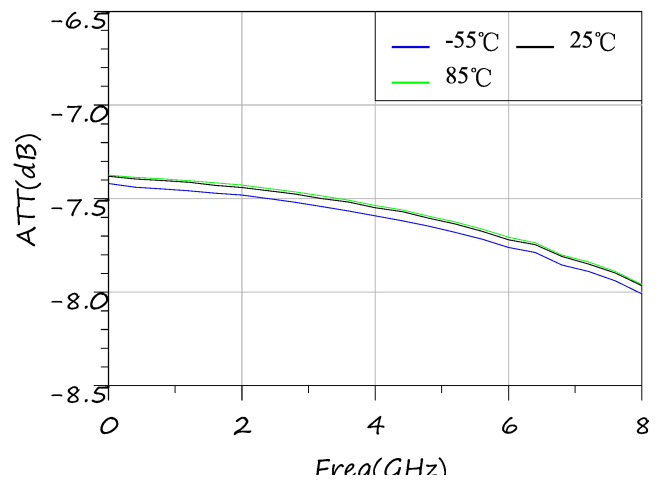

8dB Attenuation State vs Frequency

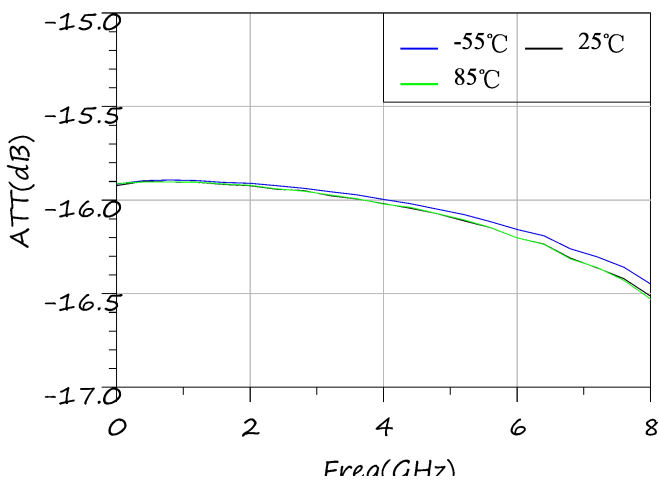

16dB Attenuation State vs Frequency

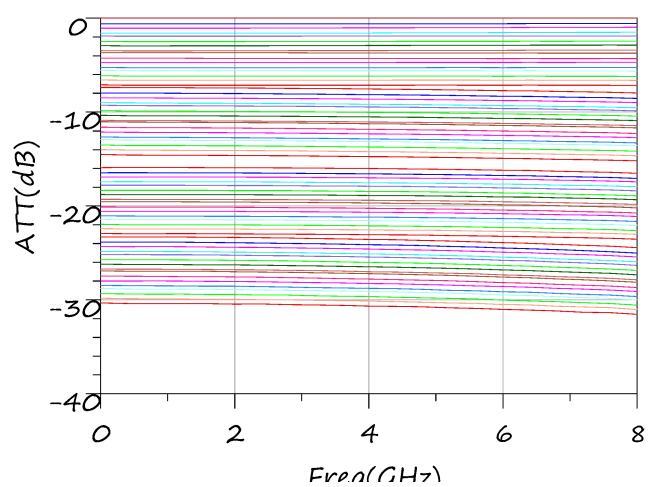

ALL Attenuation State vs Frequency

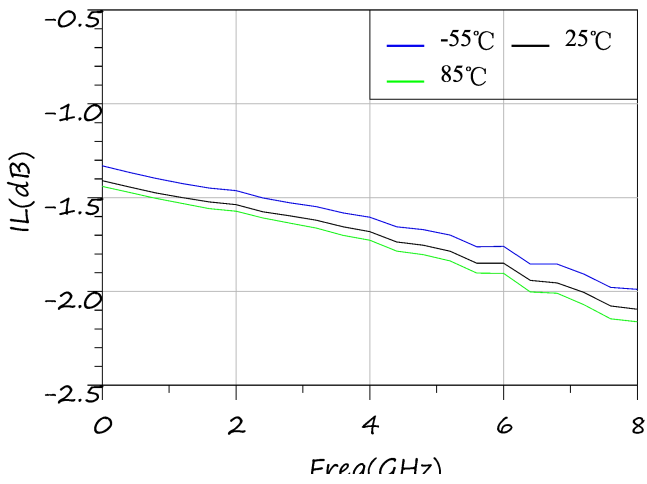

Insertion Loss vs Frequency

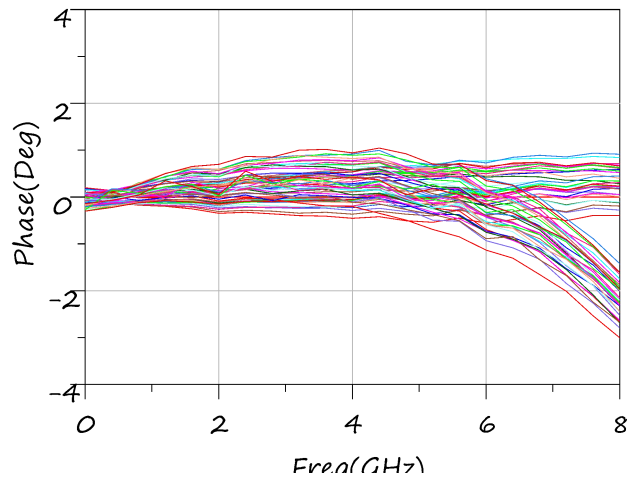

Relative Phase Shift vs Frequency

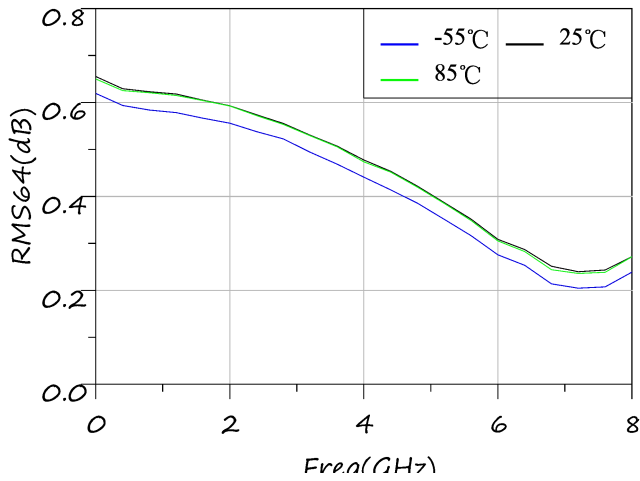

RMS 64 (dB) vs Frequency

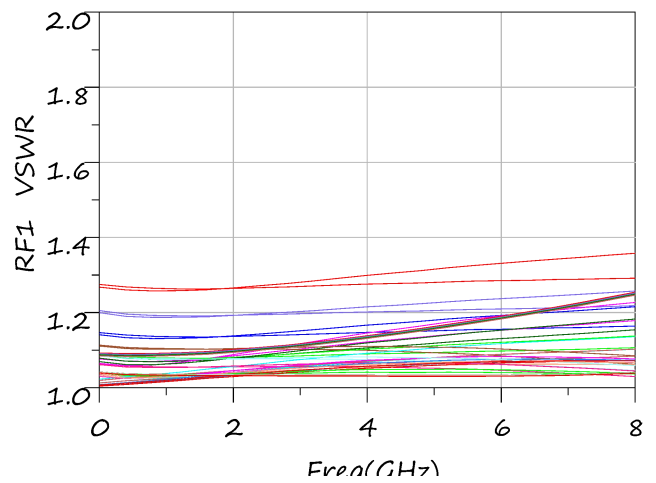

RF1 Stationary Wave vs Frequency

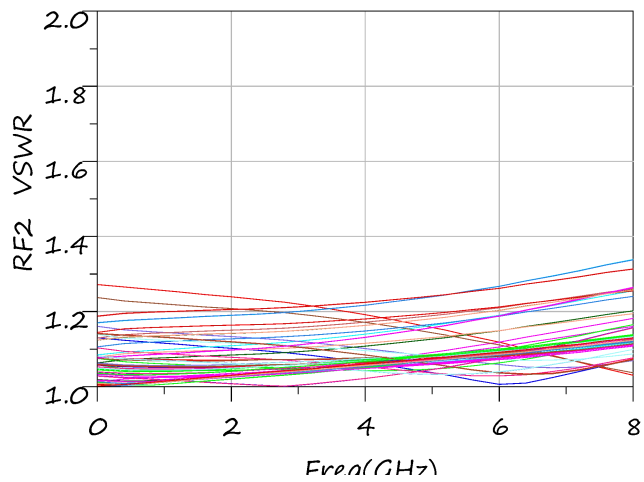

RF2 Stationary Wave vs Frequency

### Absolute Maximum Ratings

Parameter Limits	Value
Input Power, 50Ω	23dBm
Digital Control Input Voltage	0V~+5V
Storage Temperature Range	-65~+150°C
Operating Temperature Range	-55~+125°C
Mounting Temperature (30s, N <sub>2</sub> protection)	300°C
Exceeding the above conditions may cause permanent damage to the chip.	



This product is ESD(Electrostatic discharge) sensitive. Therefore, proper ESD precautions should be taken to avoid performance degradation or loss of functionality.

- Assembling in a clean environment
- Avoiding rapid temperature changes during the mounting process
- Do not touch the surface or use dry and wet chemical methods to clean the surface
- Using 2 bonding wires (shaped as figure 八) for input and output, the bonding wires should be as short as possible
- Storing in a dry, nitrogen environment

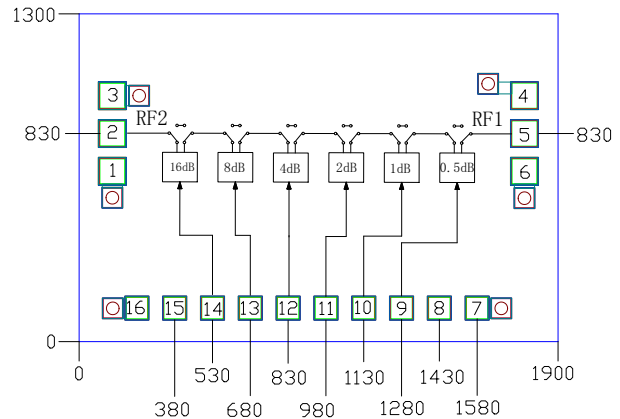

### Outline Drawing



### Notes:

1. Units:μm
2. Back side metallization: Gold
3. Back side metal is ground
4. Bonding Pad size:100μm
5. Outline Dimensional Tolerance: ±50μm

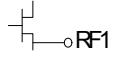
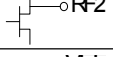
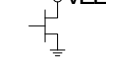
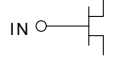
### Pad Descriptions

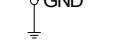
Pad Number	Function	Description	Interface Schematic
2	RF1	RF signal input/Output, 50Ω matched, Without blocking capacitor inside	
5	RF2	RF signal input/Output, 50Ω matched, Without blocking capacitor inside	
8, 15	VEE	Bias voltage terminal, -5V matched. The two VEEs are connected internally, connecting either one of them while use	
9~14	IN	DC control signal, external 0V/+3.3V voltage	
1, 3, 4, 6, 7, 16	GND	Grounding Pad for probe test	
Die Bottom	GND	Die bottom must be connected to RF/DC ground	

### Control Voltage Range

Typ.	Control Voltage Range
0V	0V~+0.5V
+3.3V	+3V~+5V

### Truth Table

Bias Voltage	Control Input						Status
	IN1	IN2	IN3	IN4	IN5	IN6	
VEE	0V	0V	0V	0V	0V	0V	Reference
-5V	0V	<b>3.3</b>	0V	0V	0V	0V	0.5dB
-5V	0V	<b>3.3V</b>	0V	0V	0V	0V	1dB
-5V	0V	0V	<b>3.3V</b>	0V	0V	0V	2dB
-5V	0V	0V	0V	<b>3.3V</b>	0V	0V	4dB
-5V	0V	0V	0V	0V	<b>3.3V</b>	0V	8dB
-5V	0V	0V	0V	0V	0V	<b>3.3V</b>	16dB

### Assembly Drawing

