

Gold Solo Twitter B
160A/80V, 140A/100V,
40A/200V
Digital Servo Drive
Installation Guide
CAN and EtherCAT

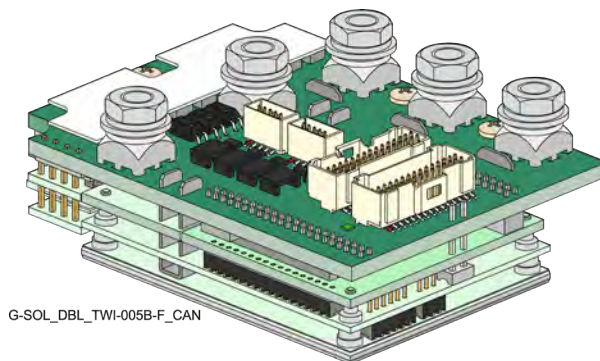
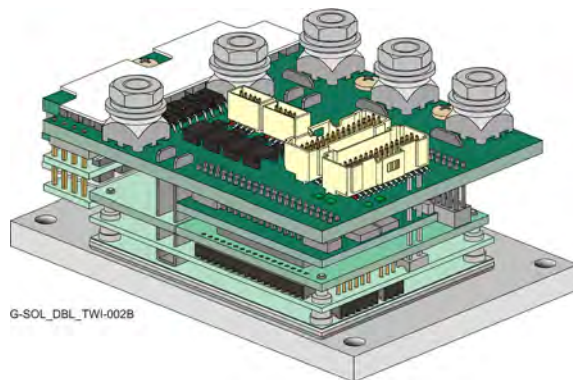

Notice

This guide is delivered subject to the following conditions and restrictions:

- This guide contains proprietary information belonging to Elmo Motion Control Ltd. Such information is supplied solely for the purpose of assisting users of the Gold Solo Twitter B servo drive in its installation.
- The text and graphics included in this manual are for the purpose of illustration and reference only. The specifications on which they are based are subject to change without notice.
- Information in this document is subject to change without notice.

Document no. MAN-G-SOLTWIB_160 (Ver. 1.001)
 Copyright © 2018
 Elmo Motion Control Ltd.
 All rights reserved.

Catalog Number

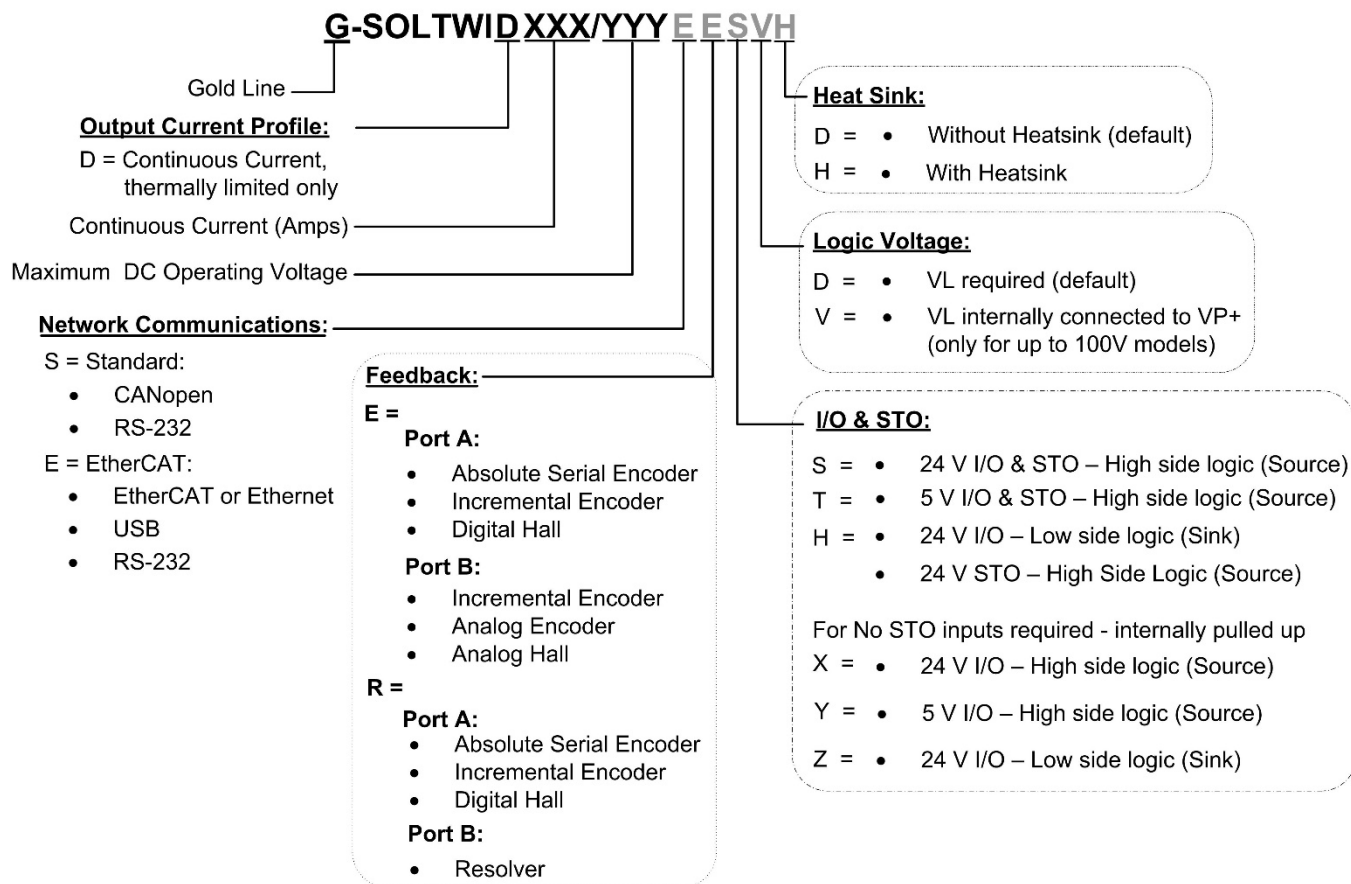

Revision History

Version	Date
Ver. 1.000	Mar 2018



- Chapter 1: This Installation Guide7**
- Chapter 2: Safety Information7**
 - 2.1. Warnings8
 - 2.2. Cautions.....8
 - 2.3. CE Marking Conformance.....8
 - 2.4. Warranty Information8
- Chapter 3: Product Description.....9**
- Chapter 4: Technical Information.....10**
 - 4.1. Physical Specifications.....10
 - 4.2. D Type Technical Data10
 - 4.3. Control Supply Input Voltage (VL).....11
 - 4.4. Product Features11
 - 4.5. Environmental Conditions.....12
- Chapter 5: Standards.....13**
 - 5.1. CE Declaration13
 - 5.2. Environmental14
 - 5.3. EMC14
 - 5.4. EtherCAT Conformance.....14
 - 5.5. Other Compliant Standards.....15
- Chapter 6: Installation.....16**
 - 6.1. Unpacking the ServoDrive Components16
 - 6.2. Mounting the Gold Solo Twitter B to a Heat Sink17
 - 6.3. The Gold Solo Twitter B Connection Diagram.....18
 - 6.3.1. CAN Connection Diagram18
 - 6.3.2. EtherCAT Connection Diagram19
- Chapter 7: Wiring.....20**
 - 7.1. Wiring Legend.....20
 - 7.2. Connectors Types22
 - 7.2.1. Recommended Cable Lugs and Cabling.....24
 - 7.3. Mating Connectors24
 - 7.4. Wiring the Female Connectors.....25
- Chapter 8: Connections26**
 - 8.1. Main, Control, and Motor Power26



- 8.1.1. Connecting the DC Power and the Motor Power Cables26
- 8.1.2. Motor Power Connections27
- 8.1.3. Motor Power29
- 8.1.4. Main Power and Control Supply.....31
 - 8.1.4.1. Main Power31
 - 8.1.4.2. Control Supply (J10).....32
 - 8.1.4.3. Dual Power Supply (PN G-SOLTWIDXXX/YYYEESDH).....33
 - 8.1.4.4. Single Power Supply (PN G-SOLTWIDXXX/YYYEESVH).....34
- 8.2. Drive Status Indicator35
- 8.3. J10 VL and Feedback Connector.....36
 - 8.3.1. Port A.....38
 - 8.3.1.1. Incremental Encoder38
 - 8.3.1.2. Absolute Serial Encoder.....38
 - 8.3.1.3. Hiperface40
 - 8.3.1.4. Hall Sensors41
 - 8.3.2. Port B.....42
 - 8.3.2.1. Incremental Encoder42
 - 8.3.2.2. Interpolated Analog Encoder42
 - 8.3.2.3. Resolver43
 - 8.3.3. Port C – Emulated Encoder Output (J10).....44
- 8.4. J11 I/O and Communication Connector45
 - 8.4.1. Digital Inputs.....47
 - 8.4.1.1. Source PLC Voltage Level Digital Input.....47
 - 8.4.1.2. Sink PLC Voltage Level Digital Input49
 - 8.4.1.3. Source 5V Logic Level Digital Input.....51
 - 8.4.2. Digital Outputs.....53
 - 8.4.2.1. Source PLC Voltage Level Digital Output53
 - 8.4.2.2. Sink PLC Voltage Level Digital Output55
 - 8.4.2.3. Digital Outputs Source 5V Logic Mode.....57
 - 8.4.3. STO (Safe Torque Off).....59
 - 8.4.4. Analog Input60
 - 8.4.5. Standard RS-23261
 - 8.4.6. USB 2.0 Communication (Only for EtherCAT version).....62
- 8.5. EtherCAT Communications Version63
 - 8.5.1. EtherCAT IN/Ethernet Connector (J17)63
 - 8.5.2. EtherCAT OUT Connector (J18)64
 - 8.5.3. EtherCAT Option.....65



- 8.5.3.1. EtherCAT Communication65
- 8.5.3.2. EtherCAT Status Indicator (D2).....66
- 8.5.3.3. EtherCAT Link Indicators (D3, D4)67
- 8.6. CAN Communications Version68
 - 8.6.1. CAN IN Connector (J17)68
 - 8.6.2. CAN OUT Connector (J18).....69
 - 8.6.3. CAN Option70
 - 8.6.3.1. Interface70
 - 8.6.3.2. CAN Layout71
- Chapter 9: Powering Up72**
 - 9.1. Initializing the System72
 - 9.2. Heat Dissipation73
 - 9.2.1. Heat Dissipation Data73
 - 9.2.2. How to Use the Chart77
- Chapter 10: Dimensions78**
 - 10.1. Dimensions including Base Heat Sink.....78
 - 10.2. Dimensions without Base Heat Sink.....80
- Chapter 11: Accessories82**



Chapter 1: This Installation Guide

This installation Guide details the technical data, pinouts, and power connectivity of the Gold Solo Twitter B. For a comprehensive detailed description of the functions and connections of the drive, refer to the Gold Panel Mounted Drives Hardware Manual.

Chapter 2: Safety Information

In order to achieve the optimum, safe operation of the Gold Solo Twitter B, it is imperative that you implement the safety procedures included in this installation guide. This information is provided to protect you and to keep your work area safe when operating the Gold Solo Twitter B and accompanying equipment.

Please read this chapter carefully before you begin the installation process.

Before you start, ensure that all system components are connected to earth ground. Electrical safety is provided through a low-resistance earth connection.

Only qualified personnel may install, adjust, maintain and repair the servo drive. A qualified person has the knowledge and authorization to perform tasks such as transporting, assembling, installing, commissioning and operating motors.

The Gold Solo Twitter B contains electrostatic-sensitive components that can be damaged if handled incorrectly. To prevent any electrostatic damage, avoid contact with highly insulating materials, such as plastic film and synthetic fabrics. Place the product on a conductive surface and ground yourself in order to discharge any possible static electricity build-up.

To avoid any potential hazards that may cause severe personal injury or damage to the product during operation, keep all covers and cabinet doors shut.

The following safety symbols are used in this and all Elmo Motion Control manuals:



Warning:

This information is needed to avoid a safety hazard, which might cause bodily injury or death as a result of incorrect operation.



Caution:

This information is necessary to prevent bodily injury, damage to the product or to other equipment.



Important:

Identifies information that is critical for successful application and understanding of the product.



2.1. Warnings

- To avoid electric arcing and hazards to personnel and electrical contacts, never connect/disconnect the servo drive while the power source is on.
- Power cables can carry a high voltage, even when the motor is not in motion. Disconnect the Gold Solo Twitter B from all voltage sources before servicing.
- The high voltage products within the Gold Line range contain grounding conduits for electric current protection. Any disruption to these conduits may cause the instrument to become hot (live) and dangerous.
- After shutting off the power and removing the power source from your equipment, wait at least 3 minutes before touching or disconnecting parts of the equipment that are normally loaded with electrical charges (such as capacitors or contacts). Measuring the electrical contact points with a meter, before touching the equipment, is recommended.



2.2. Cautions

- The maximum DC power supply connected to the instrument must comply with the parameters outlined in this guide.
- When connecting the Gold Solo Twitter B to an approved control supply, connect it through a line that is separated from hazardous live voltages using reinforced or double insulation in accordance with approved safety standards.
- Before switching on the Gold Solo Twitter B, verify that all safety precautions have been observed and that the installation procedures in this manual have been followed.
- Make sure that the Safe Torque Off is operational

2.3. CE Marking Conformance

The Gold Solo Twitter B is intended for incorporation in a machine or end product. The actual end product must comply with all safety aspects of the relevant requirements of the European Safety of Machinery Directive 2006/42/EC as amended, and with those of the most recent versions of standards EN 60204-1 and EN ISO 12100 at the least, and in accordance with 2006/95/EC.

Concerning electrical equipment designed for use within certain voltage limits, the Gold Solo Twitter B meets the provisions outlined in 2006/95/EC. The party responsible for ensuring that the equipment meets the limits required by EMC regulations is the manufacturer of the end product.

2.4. Warranty Information

The products covered in this manual are warranted to be free of defects in material and workmanship and conform to the specifications stated either within this document or in the product catalog description. All Elmo drives are warranted for a period of 12 months from the time of shipment. No other warranties, expressed or implied — and including a warranty of merchantability and fitness for a particular purpose — extend beyond this warranty.



Chapter 3: Product Description

The Ultra High Current Gold Solo Twitter B which can deliver up to 160A @ up to 75VDC, 140A @ up to 95VDC, and 40A @ up to 195VDC, are advanced high power density servo drives, delivering up to **11 kW power** in a 97.02 cm³(5.92 Inch³) compact package 47 x 69.5 x 29.7 mm (1.85" x 2.74" x 1.17").

This advanced, high power density servo drive provides top performance, advanced networking and built-in safety, as well as a fully featured motion controller and local intelligence. Power to the Gold Solo Twitter B is provided by a DC power source which is isolated from the Mains. The Gold Solo Twitter B can operate with single or dual power supplies. If separation between the main DC power source and a control supply is required, then a control supply (isolated from the Mains) is required according to the Part Number.

The drive can operate as a stand-alone device or as part of a multi-axis system in a distributed configuration on a real-time network.

The Gold Solo Twitter B drive is easily set up and tuned using the Elmo Application Studio (EASII) software tools. As part of the Gold product line, it is fully programmable with the Elmo motion control language. For more information about software tools refer to the Elmo Application Studio (EASII) User Guide.

The Gold Solo Twitter B is available in a variety of models. There are multiple power rating options, different communications options, a number of feedback options and different I/O configuration possibilities.

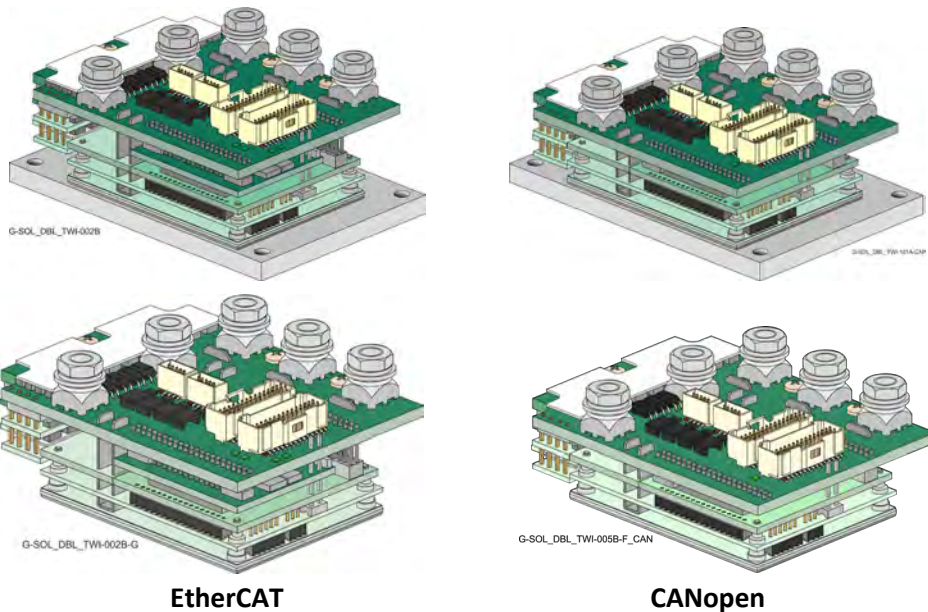

Figure 1: Difference between 4-Tier EtherCAT and 3-Tier CANopen modules with/without heatsink



Chapter 4: Technical Information

4.1. Physical Specifications

Feature	Units	All Types
Weight with heatsink	g (oz)	~120.0 g (4.23 oz)
Weight without heatsink	g (oz)	~86.0 g (3.03 oz)
EtherCAT Version Dimension with heatsink	mm (in)	47 x 69.5 x 29.7 mm (1.85" x 2.74" x 1.17")
EtherCAT Version Dimension without heatsink	mm (in)	46.3 x 62.5 x 25.7 mm (1.82" x 2.46" x 1.01")
CAN Version Dimension with heatsink	mm (in)	47 x 69.5 x 26.9 mm (1.85" x 2.74" x 1.06")
CAN Version Dimension without heatsink	mm (in)	46.3 x 62.5 x 22.9 mm (1.82" x 2.46" x 0.90")
Mounting method		Panel Based Mounting

4.2. D Type Technical Data

Feature	Units	D160/80	D140/100	D40/200
Minimum supply voltage	VDC	11		20
Nominal supply voltage	VDC	65	85	170
Maximum supply voltage	VDC	75	95	195
Maximum continuous Electrical power output	kW	10	11	7
Efficiency at rated power (at nominal conditions)	%	> 99		
Maximum output voltage		Up to 96% of DC bus voltage		
Amplitude sinusoidal/DC continuous current	A	160	140	40
3-Phase Sinusoidal continuous RMS current limit (I _c)	A	113	99	28
DC Motor (any two phase motor)	A	100		40
Current limit	A	Max Output current is guaranteed for T _{Heat-Sink} <85°C		

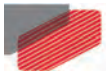

4.3. Control Supply Input Voltage (VL)

The Control Supply input voltage (VL) must be either SELV or PELV rated.

Feature	Unit	Details
Standard CAN (S option)		
Input range	V	12V – 95V
Power consumption (including 5 V/200 mA for encoder)	W	<2.5W
ETHERCAT (E option)		
Input range	V	12V – 95V
Power consumption (including 5 V/200 mA for encoder)	W	<4W

4.4. Product Features

Main Feature	Details	Presence / No.
STO	+5V Logic, Opto isolated from the Control section, <i>or</i>	✓
	PLC Source, Opto isolated from the Control section	✓
Digital Input	+5V Logic, Opto isolated from the Control section <i>or</i>	6
	PLC Source, Opto isolated from the Control section <i>or</i>	6
	PLC Sink Opto isolated from the Control section	6
Digital Output	+5V Logic, Opto isolated from the Control section <i>or</i>	4
	PLC Source, Opto isolated from the Control section <i>or</i>	4
	PLC Sink, Opto isolated from the Control section	4
Analog Input	Differential ±10V or Single Ended	1
Feedback	Standard Port A, B, & C	✓
Communication Option	USB (only for EtherCAT version)	✓
	EtherCAT <i>or</i>	✓
	CAN	✓
	Standard RS232	✓



4.5. Environmental Conditions

You can guarantee the safe operation of the Gold Solo Twitter B by ensuring that it is installed in an appropriate environment.



Warning: During operation the Gold Solo Twitter B becomes hot to the touch (the heatsink and wires may heat up to 92 °C). Care should be taken when handling it.



Caution:
The Gold Solo Twitter B dissipates its heat by convection or by conduction. The maximum ambient operating temperature of 50 °C (122°F) must not be exceeded.

Feature	Details
Operating ambient temperature in compliance with STO standards	0 °C to 40 °C (32 °F to 104 °F)
Operating ambient temperature according to IEC60068-2-2	0 °C to 50 °C (32 °F to 122 °F) in compliance with UL standards
Storage temperature	-20 °C to +85 °C (-4 °F to +185 °F)
Maximum non-condensing humidity according to IEC60068-2-78	95%
Maximum Operating Altitude	2,000 m (6562 feet) It should be noted that servo drives capable of higher operating altitudes are available on request.
Mechanical Shock according to IEC60068-2-27	15g / 11ms Half Sine
Vibration according to IEC60068-2-6	5 Hz ≤ f ≤ 10 Hz: ±10mm 10 Hz ≤ f ≤ 57 Hz: 4G 57 Hz ≤ f ≤ 500 Hz:5G



Chapter 5: Standards

The following table describes the Main Standards of the Gold Solo Twitter B servo drive. For further details refer to the MAN-G-Panel Mounted Drives Hardware manual.

Main Standards	Item
The related standards below apply to the performance of the servo drives as stated in the environmental conditions in section 4.5 Environmental Conditions above.	
Pending STO IEC 61800-5-2:2007 SIL 3	Adjustable speed electrical power drive systems – Safety requirements – Functional
Pending EN ISO 13849-1:2008 PL e, Cat 3	Safety of machinery — Safety-related parts of control systems.
In compliance with UL61800-5-1	Adjustable speed electrical power drive systems Safety requirements – Electrical, thermal and energy
Conformity with CE 2006/95/EC	Low-voltage directive 2006/95/EC
In compliance with CSA C22.2 NO. 274-13	Adjustable speed drive

5.1. CE Declaration

This manual is considered to be “original instructions” as defined in EC Directive 2006/42/EC and the contents have been verified by Elmo Motion Control. The products covered by this manual comply with the following directives. The complete EC Declaration of Conformity is available on the internet at <http://www.elmomc.com/standards/files/CE-DECLARATION-OF-CONFORMITY.pdf>.

Specification	Details
Conformity with CE 2006/95/EC	EC Low Level Directive, 2006/95/EC as per Gold Line CE Declaration.
Conformity with CE 2004/108/EC	EC Electromagnetic Compatibility Directive 2004/108/EC as per Gold Line CE Declaration.
Conformity with CE 2006/42/EC	Machinery Directive 2006/42/EC as per Gold Line CE Declaration.



5.2. Environmental

Specification	Details
Approved IEC60068-2-78	Environmental testing – Damp heat, steady state
Approved IEC60068-2-6	Environmental testing –Vibration (sinusoidal)
Approved IEC60068-2-2	Environmental testing – Dry heat
Approved IEC60068-2-27	Basic environmental testing procedures - Shock

5.3. EMC

Specification	Details
Approved IEC/EN 61800-3	Adjustable speed electrical power drive systems
Approved IEC 61326-3-1	Electrical equipment for measurement, control and laboratory use. Standard required for STO.

5.4. EtherCAT Conformance

EtherCAT Conformance Test Certified
Approved and certified EtherCAT conformance



5.5. Other Compliant Standards

Quality Assurance	
ISO 9001:2008	Quality Management
Design	
<ul style="list-style-type: none"> • IPC-D-275 • IPC-SM-782 • IPC-CM-770 	Printed wiring for electronic equipment (clearance, creepage, spacing, conductors sizing, etc.)
Reliability	
MIL-HDBK- 217F	Reliability prediction of electronic equipment (rating, de-rating, stress, etc.)
Workmanship	
In compliance with IPC-A-610, level 3	Acceptability of electronic assemblies
PCB	
In compliance with IPC-A-600, level 3	Acceptability of printed circuit boards
Packing	
In compliance with EN 100015	Protection of electrostatic sensitive devices
Environmental	
In compliance with 2002/96/EC	Waste Electrical and Electronic Equipment regulations (WEEE) Note: Out-of-service Elmo drives should be sent to the nearest Elmo sales office.
In compliance with 2002/95/EC (effective July 2006)	Restrictions on Application of Hazardous Substances in Electric and Electronic Equipment (RoHS)



Chapter 6: Installation

6.1. Unpacking the ServoDrive Components

Before you begin working with the Gold Solo Twitter B, verify that you have all of its components, as follows:

- The Gold Solo Twitter B servo drive
- The Elmo Application Studio (EASII) software and software manual

The Gold Solo Twitter B is shipped in a cardboard box with Styrofoam protection.

To unpack the Gold Solo Twitter B:

1. Carefully remove the servo drive from the box and the Styrofoam.
2. Check the drive to ensure that there is no visible damage to the instrument. If any damage has occurred, report it immediately to the carrier that delivered your drive.
3. To ensure that the Gold Solo Twitter B you have unpacked is the appropriate type for your requirements, locate the part number sticker on the side of the Gold Solo Twitter B. It looks like this:

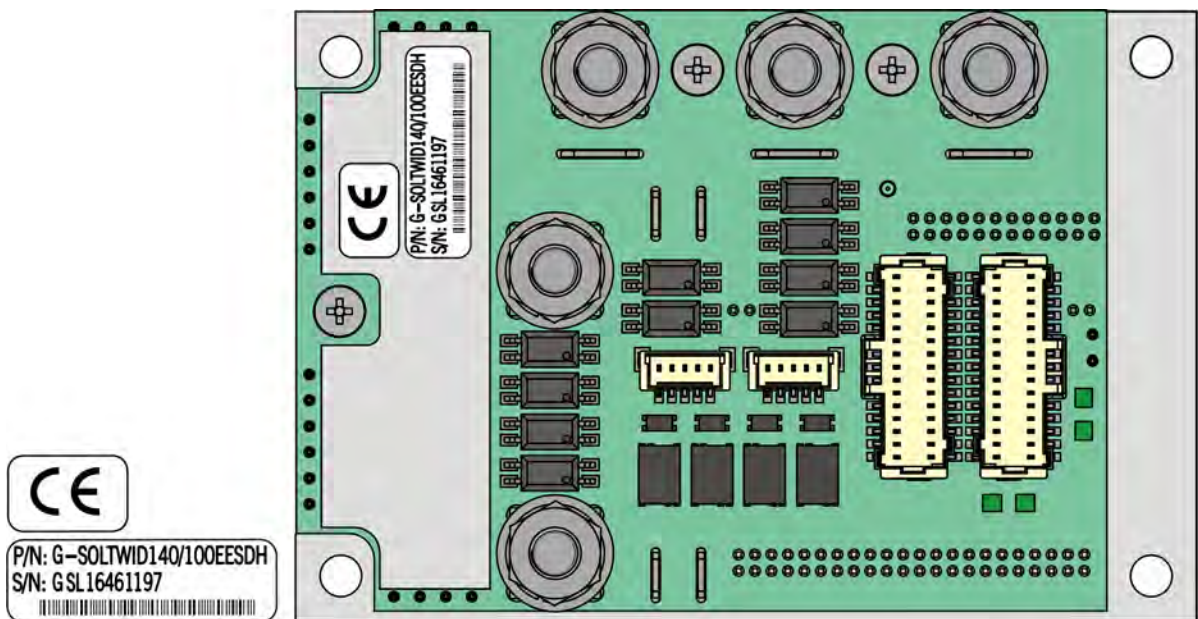

G-SOL_DBL_TWI-009C

4. Verify that the Gold Solo Twitter B type is the one that you ordered, and ensure that the voltage meets your specific requirements.

The part number at the top provides the type designation. Refer to the appropriate part number in the section Catalog Number at the beginning of the installation guide.



6.2. Mounting the Gold Solo Twitter B to a Heat Sink

The selected heat sink must be screwed to the lower surface of the Gold Solo Twitter B.

To mount the heat sink:

1. Mount the heat sink under the base of the Gold Solo Twitter B.
2. Place the Thermal foil (enclosed in the heat sink accessories kit) between the lower surface of the servo drive, and the upper surface of the heat sink
3. Use four M2 screws (enclosed in the heat sink accessories kit) to secure the heat sink under the servo drive.

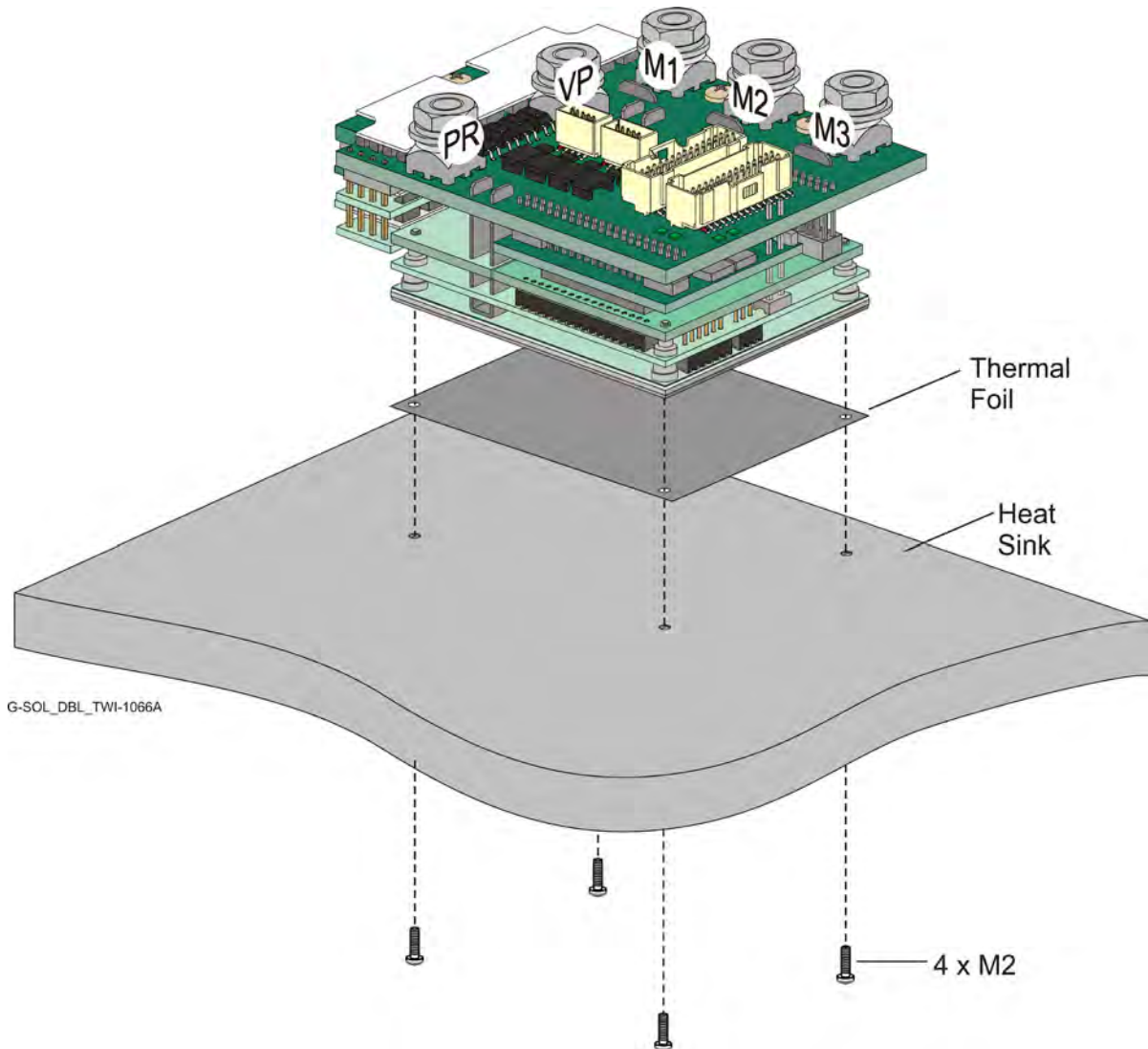

Figure 2: Mount the Heat Sink and Thermal Foil to the Gold Solo Twitter B



6.3. The Gold Solo Twitter B Connection Diagram

6.3.1. CAN Connection Diagram

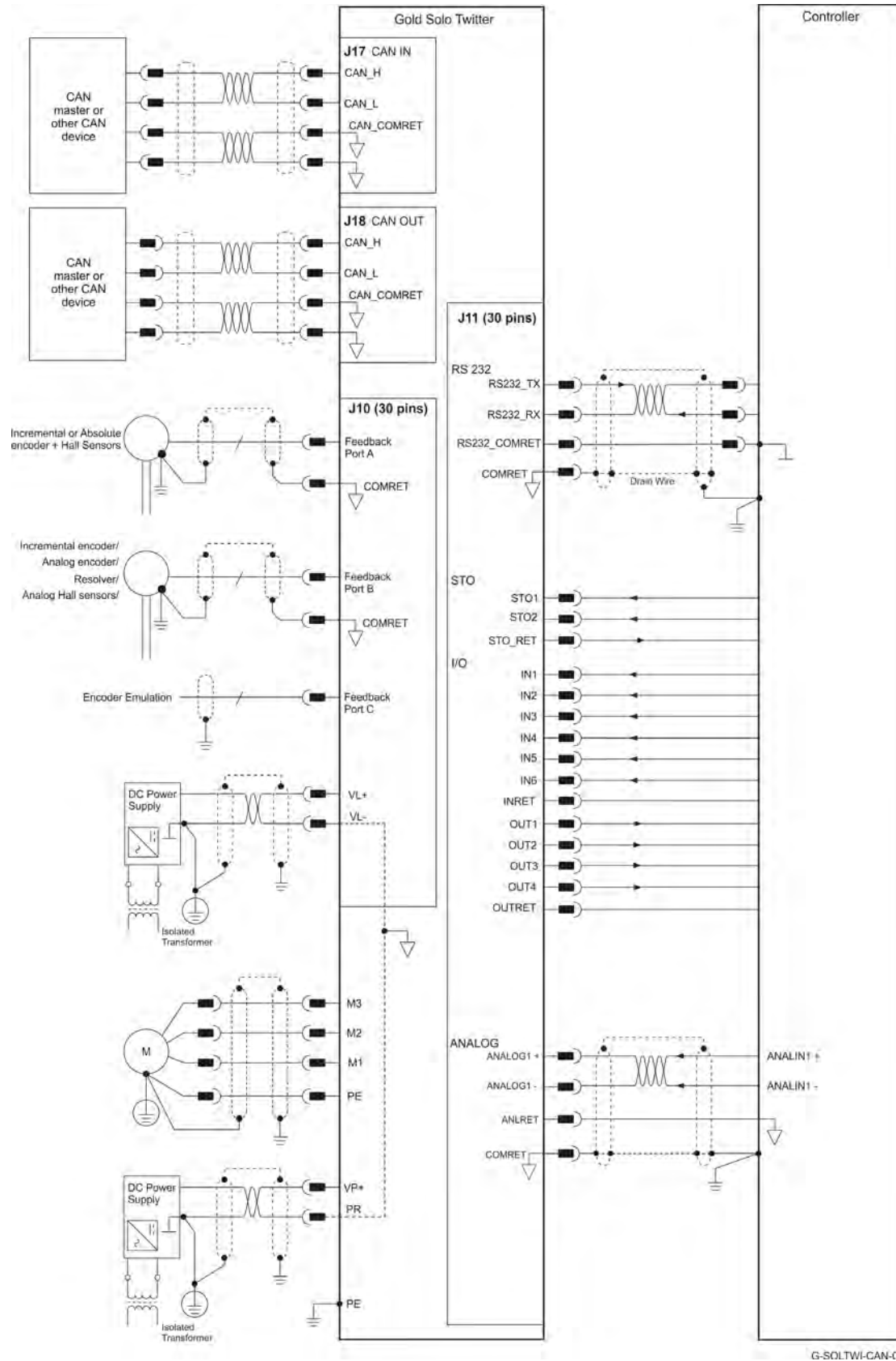
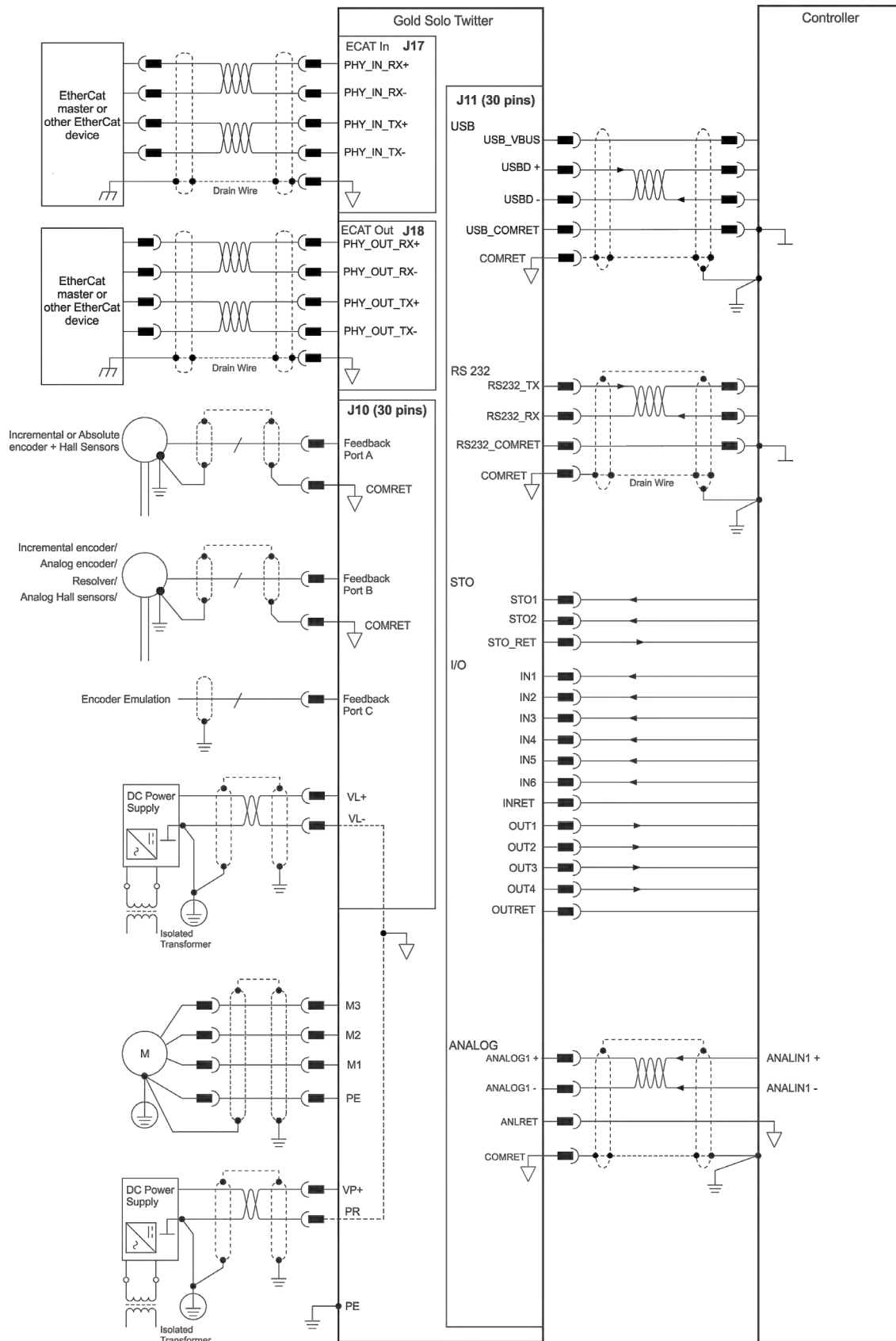

Figure 3: The Gold Solo Twitter B CAN Connection Diagram



6.3.2. EtherCAT Connection Diagram



G-SOLTW001D



Figure 4: The Gold Solo Twitter B EtherCAT Connection Diagram



Chapter 7: Wiring

7.1. Wiring Legend

The following table legend describes the wiring symbols detailed in all installation guides. All the wiring diagrams show wiring for D-TYPE connectors.

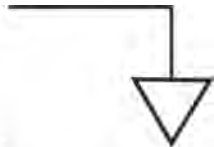
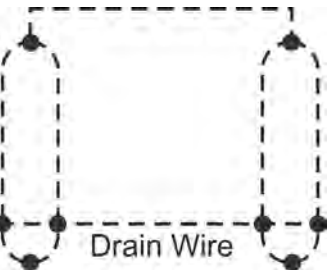
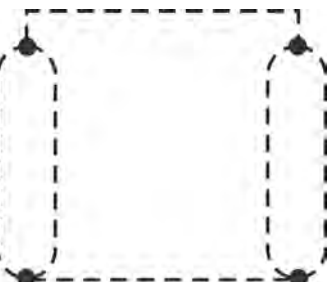
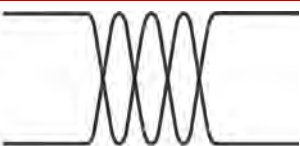
Wiring Symbol	Description
 GGEN_101D-A	Earth connection (PE)
 GGEN_101D-B	Protective Earth Connection
 GGEN_101D-C	Common at the Controller
 GGEN_101D-D	Shielded cable with drain wire. The drain wire is a non-insulated wire that is in direct contact with the braid (shielding). Shielded cable with drain wire significantly simplifies the wiring and earthing.
 GGEN_101D-E	Shielded cable braid only, without drain wire.
 GGEN_101D-F	Twisted-pair wires

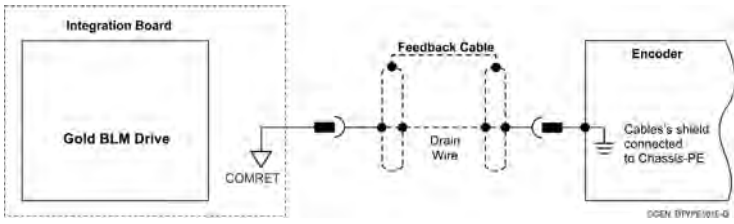

Wiring Symbol	Description
 <p>The diagram illustrates the electrical connection for encoder earthing. On the left, an 'Integration Board' contains a 'Gold BLM Drive' with a 'COMRET' terminal connected to ground. A 'Feedback Cable' connects this terminal to an 'Encoder'. The cable includes a 'Drain Wire' and its shield is connected to 'Chassis-PE'. The encoder also has a connection to 'Chassis-PE'.</p>	<p>Encoder Earthing.</p> <p>The cable's shield is connected to the chassis (PE) in the connector.</p> <p>Earthing the Encoder and connecting the Earth (PE) to the drive COMRET is mandatory to insure reliable operation, high noise immunity and rejection of voltage common mode interferences.</p>



7.2. Connectors Types

The Gold Solo Twitter B has the following types of connectors.

Type	Function	Port	Connector Location
Terminal Lug + M4 Flat Washer + M4 Spring Washer + M4 Nut	Power	VP+, PR	<p>G-SOL_DBL_TWI-006C-A</p>
	Motor	M1, M2, M3	
Terminal Lug + M3 Flat Washer + M3 Spring Washer + M3 screw	Earth Connection	PE, PE,	<p>G-SOL_DBL_TWI-006C-B</p>
			<p>Note: For Gold Solo Twitter B drives without a heatsink, connect the PE to the chassis of the machine.</p>
Recommended for M4 screw		Terminal Lug (FLEX) Stud hall size: M4	



Pins	Type	Function
------	------	----------

Connectors Location

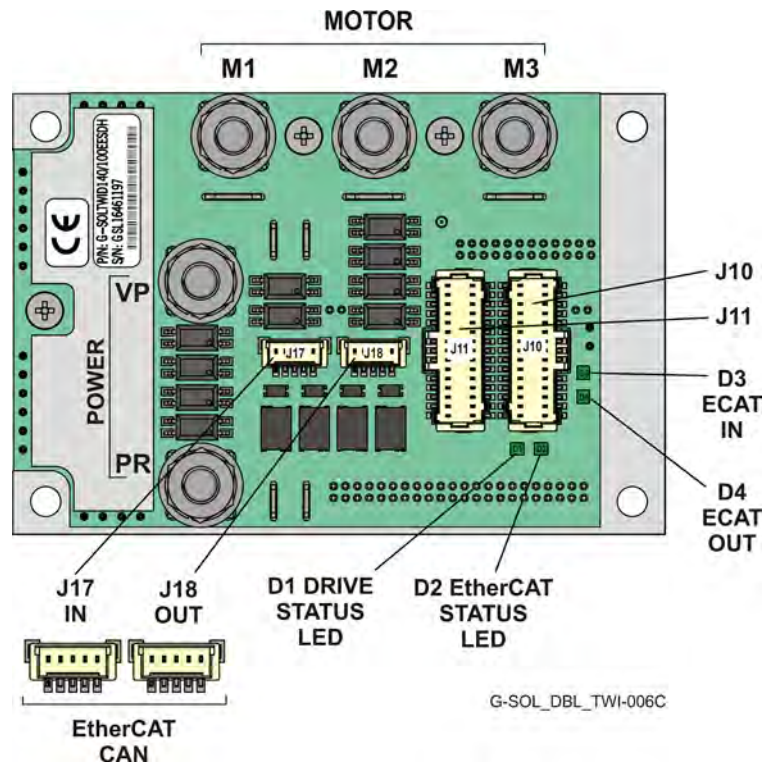

Pins	Type	Function
------	------	----------

	Redcube Terminal screw, M4 Flat Washer, M4 Spring Washer, and M4 Nut	Power, Motor
--	--	--------------

2 rows x 15 Pins	Molex type	J10 - VL & Feedback Ports
------------------	------------	---------------------------

2 rows x 15 Pins	Molex type	J11 - IO and Communication
------------------	------------	----------------------------

EtherCAT/CAN

5	Molex type	J17 - CAN/EtherCAT IN Communication
---	------------	-------------------------------------

5	Molex type	J18 - CAN/EtherCAT OUT Communication
---	------------	--------------------------------------



7.2.1. Recommended Cable Lugs and Cabling

Elmo recommends the following cable lugs depending on the cable to be installed. Refer to the specification drawings for the UL listed lug and cable application.

Panduit Copper Lug - One-Hole, Standard Flex Barrel 6, 8, 10, 12, 14 Gauge

Part No.	Current (A) (Up to)	Wire Size (Max mm)	Wire Type	Wire Strip Length (mm)	Stud Size
PV6-8R	160	8.64	#6 AWG	11.1+0.8	M4(#8)
PV8-8R	100	7.11	#8 AWG	9.5 + 0.8	M4(#8)
PV10-8R	90	5.72	#10 AWG	7.93 + 0.8	M4(#8)
PV12-8HDR	40	5.8	#12 AWG	7.1 + 0.8	M4(#8)
PV14-8R	20	4.3	#14 AWG	7.9 + 0.8	M4(#8)

7.3. Mating Connectors

Connector	Mating Connector Type	Mating Crimping Pins
J10, J11 VL & Feedback Ports IO and Communication	MOLEX 1.00mm "Pico-Clasp" 501189-3010	MOLEX 1.00mm crimp terminal 501193-3000
J17, 18 IN/OUT CAN/EtherCAT Communication	MOLEX 1.00mm "Pico-Clasp" 501330-0500	MOLEX 1.00mm crimp terminal 501334-0100



7.4. Wiring the Female Connectors

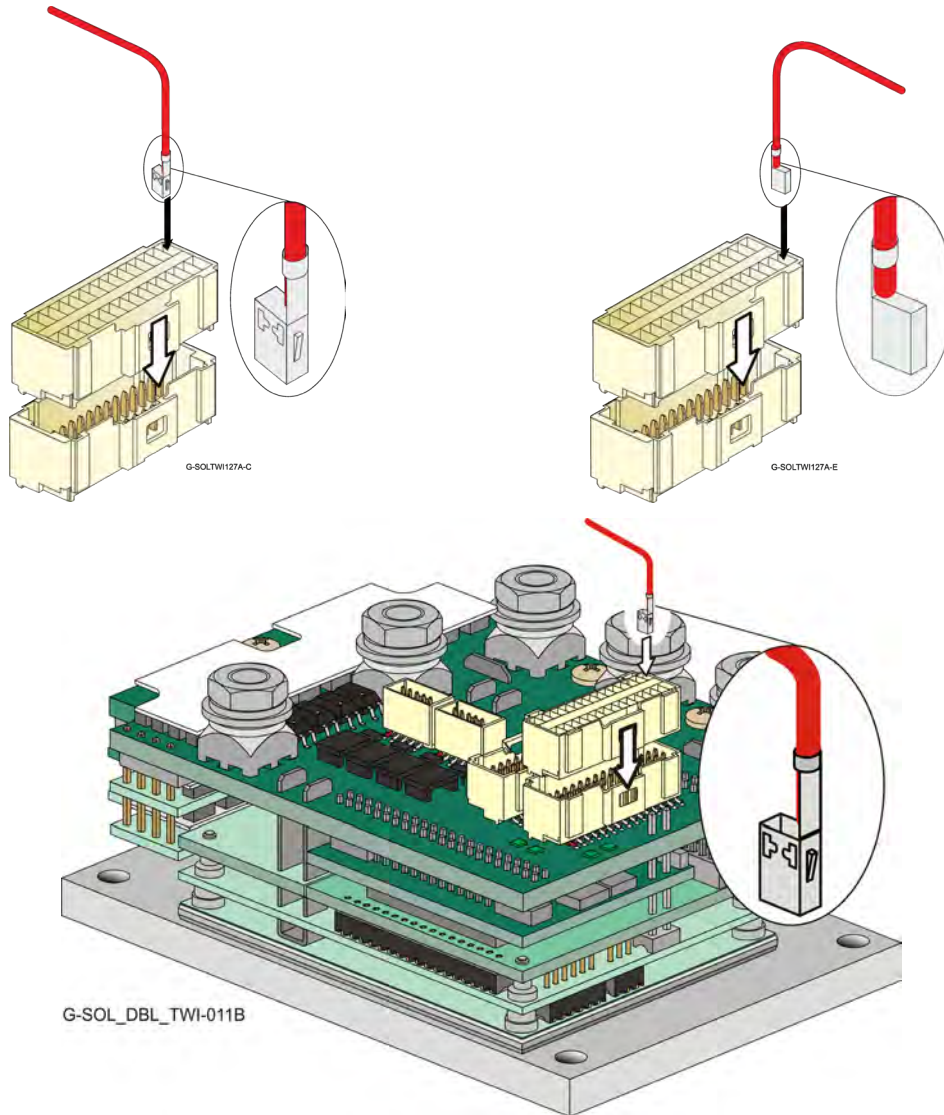

Figure 5: Inserting a wire/pin to the Female Connector

To insert a wire/pin to the female connectors of J10, J11, J17, and J18 do the following:

1. Select the relevantly colored wire to insert to a specific rectangular compartment on the female connector.
2. Use the appropriate Molex crimping plier (Molex P/N 63819-1500) to fasten a pin connector to the end of the wire.
3. Place the connector on a flat surface, in the orientation as shown in Figure 5. Notice that the rectangular slot has a niche at the bottom of the slot.
4. Insert the wire connector to the slot as shown in Figure 5. Make sure that the connector protrusion is inserted to the bottom of the rectangular slot. When inserting the wire connector to a slot in the second row, make sure to rotate the connector in the opposite orientation.
5. Repeat the same procedure for any other wire connections.



Chapter 8: Connections

8.1. Main, Control, and Motor Power

This section describes the Main and Control supplies, and Motor Power connections. The Motor and Main Power interface uses lugs and cables defined in section 7.2.1 Recommended Cable Lugs and Cabling.

8.1.1. Connecting the DC Power and the Motor Power Cables

This section describes the installation of the cable terminal lugs for both the Main Power Cables to VP+, PR, and PE terminals on the Gold Solo Twitter B (with and without heatsink), and the Motor Power cables to the M1, M2, M3, and PE terminals on the Gold Solo Twitter B (with and without heatsink).

Note: When connecting several motors, all the motor phases must be connected in an identical sequence.

Step 1: PE Earth Connection

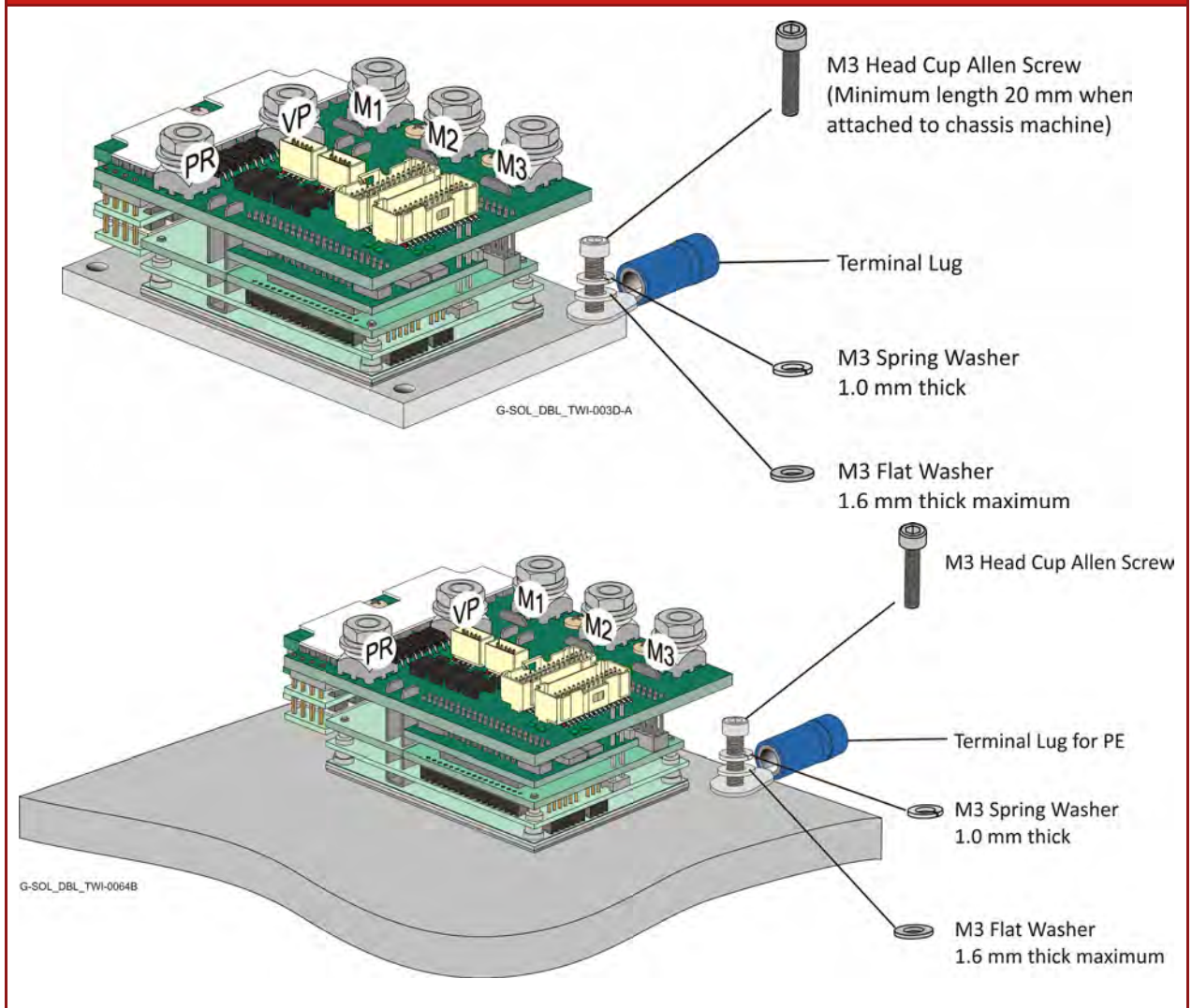

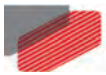

Step 2: Power and Motor Connection

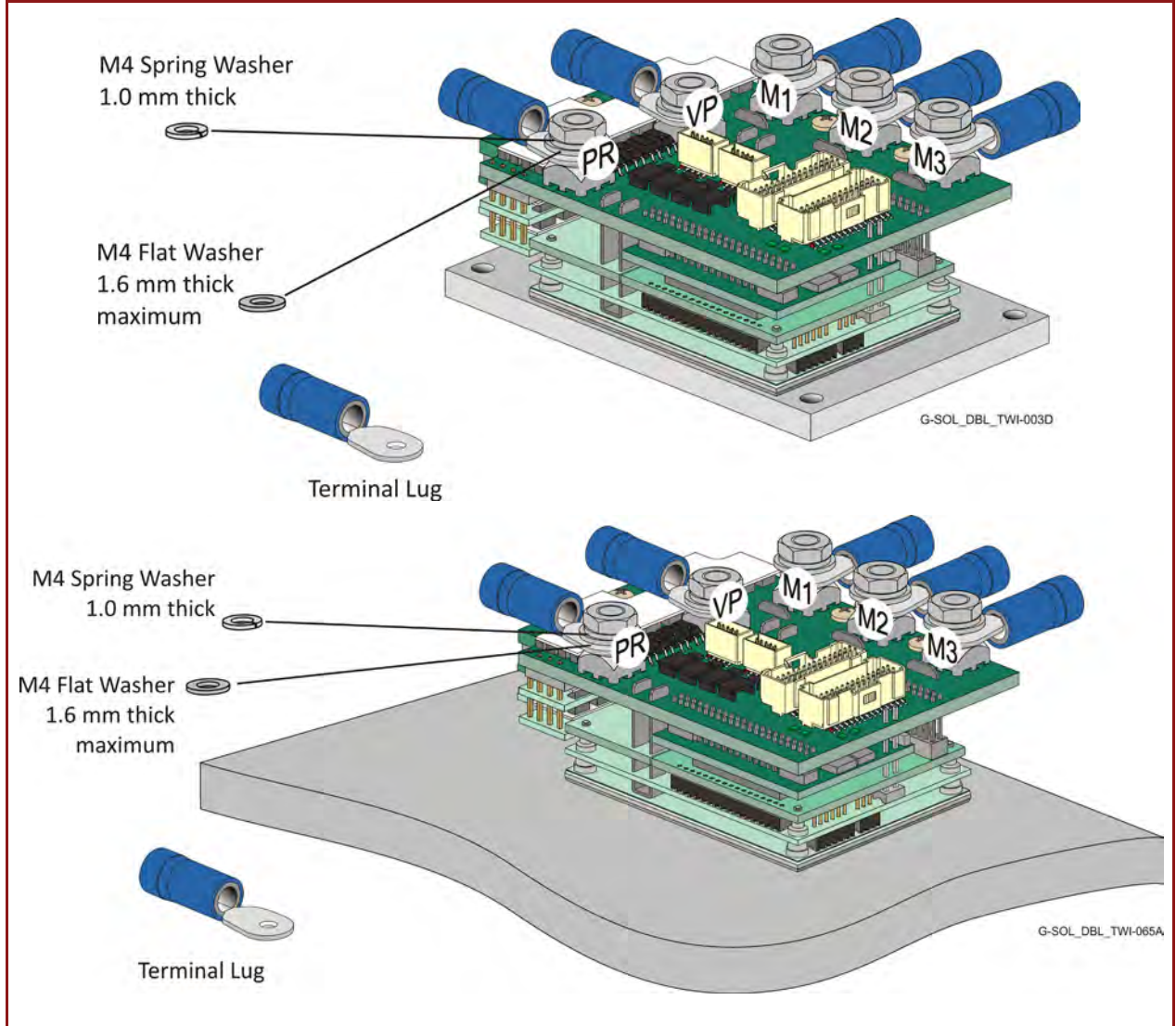

Table 1: Connecting the Main Power and Motor Cables

8.1.2. Motor Power Connections

1. For best immunity, it is highly recommended to use a 4-wire shielded (not twisted) cable for the motor connection. The gauge is determined by the actual RMS current consumption of the motor.

Connect the cable shield to the closest ground connection at the motor end.

For better EMI performance, the shield should be connected to Earth Connection (heat sink mounting holes).

2. Ensure that the motor chassis is properly earthed.
3. Connect the appropriate terminal lugs from the Motor Power cables to the M1, M2, M3, and PE terminals on the Gold Solo Twitter B.

The phase connection is arbitrary as Elmo Application Studio (EAS II) will establish the proper commutation automatically during setup. When tuning a number of drives, you can copy the setup file to the other drives and thus avoid tuning each drive separately. In this case the motor-phase order must be the same as on the first drive.



- a. Install the motor cable to the drive using the recommended Terminal Lug (FLEX), M4 flat washer, M4 spring washer, and secure with an M4 nut (to the drive). The required M4 nut torque is typically 1.2 Nm.
- b. Install the recommended PE wire to the drive, using a barrel connector, M3 flat washer, M3 spring washer, and secure with an M3 head cup Allen screw to the heatsink. The required M3 screw torque is typically 1.2 Nm.



8.1.3. Motor Power

For full details see Section 7.3 in the manual: MAN-G-Board Level Modules Hardware manual.

Pin	Function	Cable		Pin Positions
		Brushless Motor	Brushed DC Motor	
PE	Connection earth	Motor	Motor	
M1	Motor phase	Motor	N/C	
M2	Motor phase	Motor	Motor	
M3	Motor phase	Motor	Motor	

Table 2: Motor Terminals

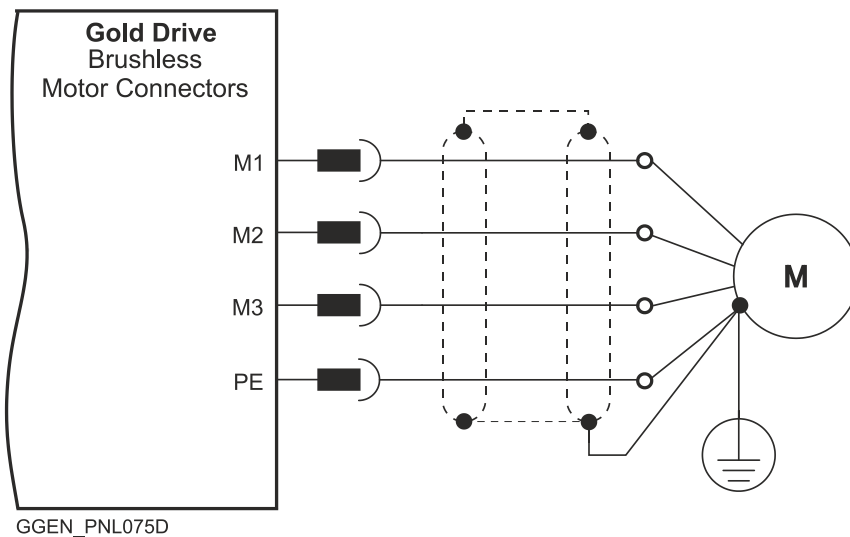

Figure 6: Brushless Motor Power Connection Diagram

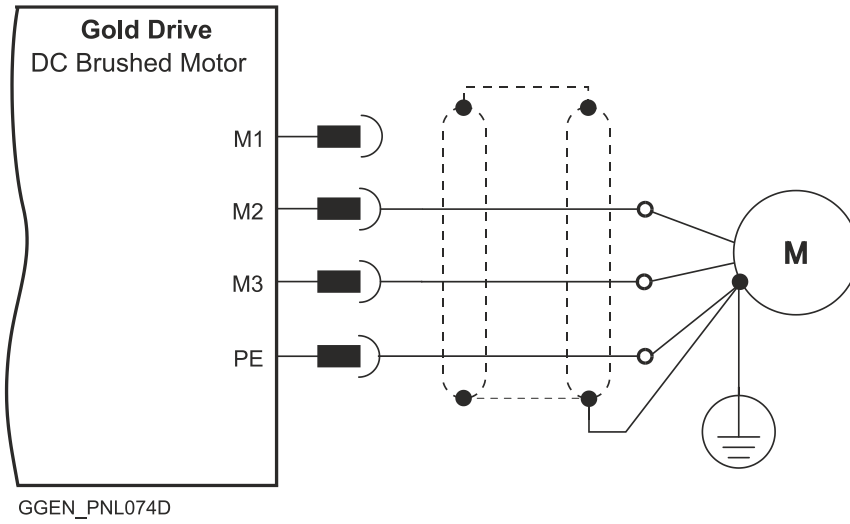

Figure 7: Brushed Motor Power Connection Diagram



8.1.4. Main Power and Control Supply

This section describes the Main Power and the Control supply connector.

8.1.4.1. Main Power

The isolated DC power source is not included with the Gold Solo Twitter B.

Pin	Function	Cable	Pin Positions
VP+	DC Pos. Power input	Power	<p>The diagram shows two views of the main power connector. The top view is labeled 'G-SOL_DBL_TWI-006C-A' and the bottom view is labeled 'G-SOL_DBL_TWI-006C-B'. Both views show a green PCB with three motor terminals (M1, M2, M3) at the top, labeled 'MOTOR'. On the left side, there are three power terminals: VP+ (top), PR (middle), and PE (bottom), labeled 'POWER'. The PCB also features a CE mark and a label with the part number 'MAN-G-SOLTWIB_160' and 'SN: G-SOL1601157'.</p>
PR	Power return	Power	
PE	Connection earth	Power	

Table 3: Main Power Terminals

Connect the DC power cable to the VP+ and PR terminals on the main power connector.

To connect the Gold Solo Twitter to the DC power source:

1. The source of the VDC power supply must be isolated from the Mains.
2. Verify that the rectified VDC is indeed within the range of the drive.
3. Connect the cable shield to the closest earth connection near the power supply.
4. Connect the PE to the closest earth connection near the power supply.
5. Connect the PR to the closest earth connection near the power supply.
6. Before applying power, first verify the polarity of the connection.



8.1.4.2. Control Supply (J10)

Connect the VL+ and VL- pins on the Gold Solo Twitter B in the manner described in the table and drawing below.

Pin	Signal	Function	Pin Positions
30	VL+	Control Supply Input	
29	VL-	Control Supply Return	
<p>1. Standard CAN (S option) Input range: 12VDC – 95VDC Power consumption: <2.5W (including 5 V/200 mA for encoder)</p> <p>2. EtherCAT (E option) Input range: 12VDC – 95VDC Power consumption: <4W (including 5 V/200 mA for encoder)</p>			

Table 4: Control Supply Pins

Connect the VL+ and VL- terminals to the power supply Control Connector.

To connect your integration board product to the control supply:

1. The source of the control supply must be isolated from the Mains.
2. For safety reasons, connect the return (common) of the control supply source to the closest earth connection near the control supply source.
3. Connect the cable shield to the closest earth connection near the control supply source.
4. Before applying power, first verify the polarity of the connection.



8.1.4.3. Dual Power Supply (PN G-SOLTWIDXXX/YYEESDH)

Whenever dual power supply is selected by its part number, a separate supply for the Logic is required. Both the Power and Logic supplies are required to be isolated-from-the-mains:

- A battery or main DC power source rectified from the Mains, according to specification
- A control supply for the logic (VL+, VL-)

The following figure describes an ordinary power supply for Servo drives with sufficient internal capacitance and shunt regulator to manage power flow in both directions to-and-from the motor.

Note: The PR, COMRET, and VL- are connected internally in the Gold Solo Twitter B.

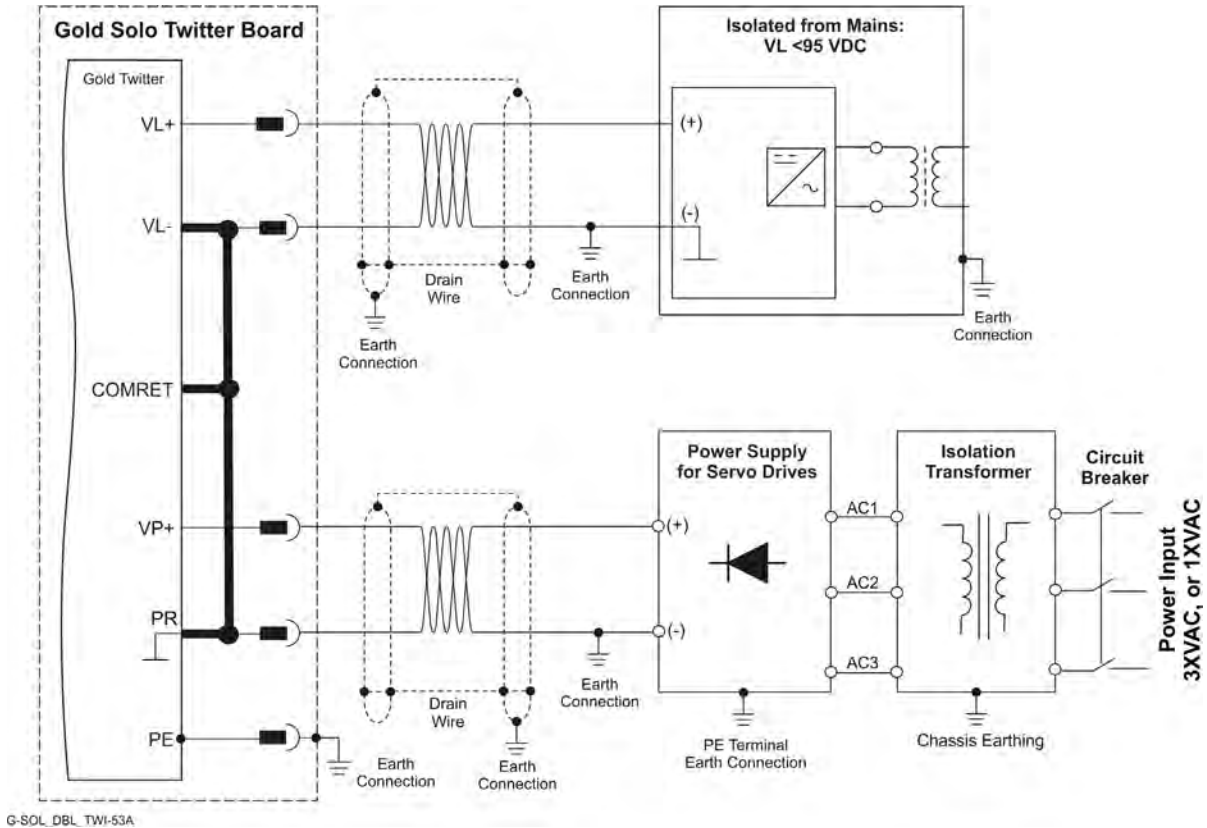

Figure 8: Separate VP and VL Power Supplies Connection Diagram



8.1.4.4. Single Power Supply (PN G-SOLTWIDXXX/YYYEESVH)

Where a single power supply is selected by its part number (VL+ connected to VP+), the absolute maximum VP+ and VL+ voltage must be < 95VDC, under all conditions, to prevent VL+ supply failure.

A single power supply can be used for the main and control power in the range of 12VDC to 95VDC.

The following figure describes a single connection of main power and control

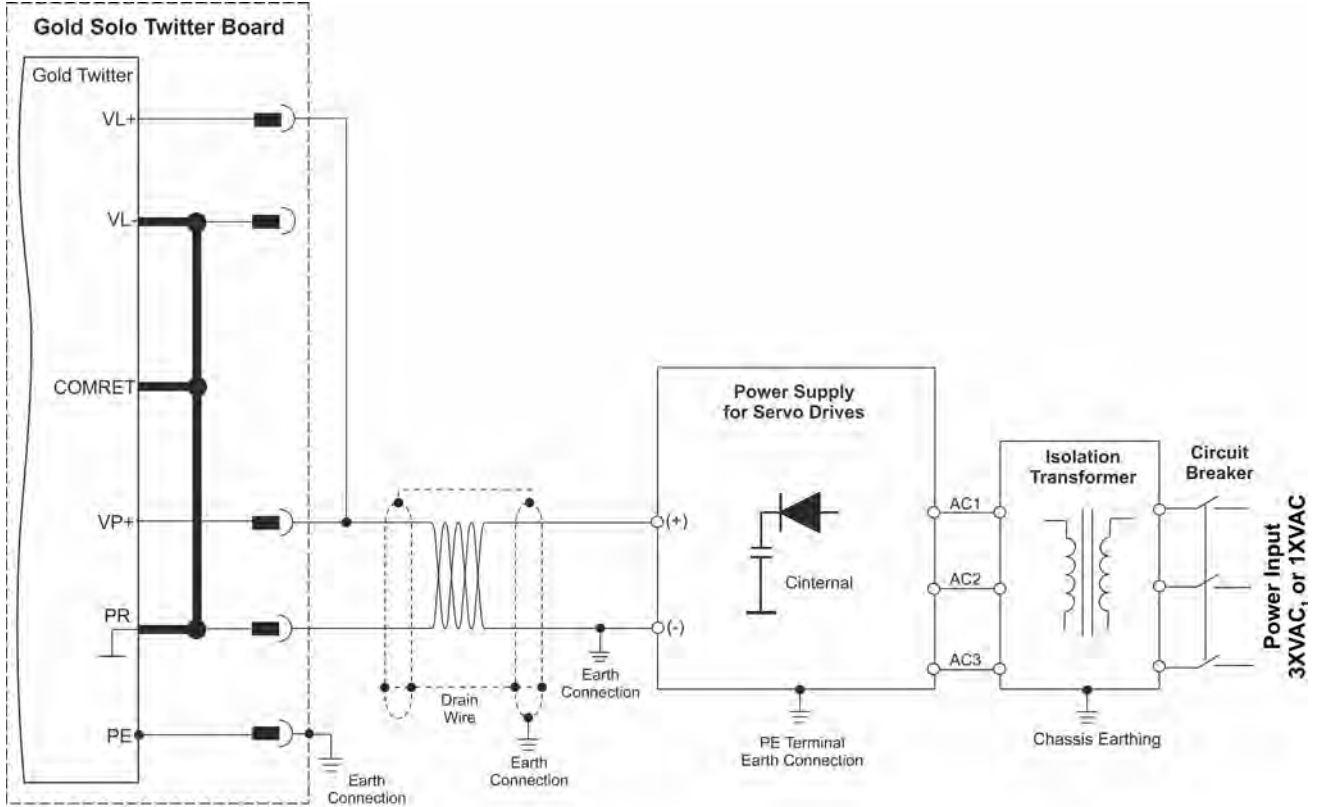

Figure 9: Single Power Supply (VP+ <95V) Connection Diagram

Note: This option is available for 80VDC and 100VDC models only.



8.2. Drive Status Indicator

Figure 10 shows the position of the D1 red/green dual LED, which is used for immediate indication of the Initiation and Working states. For details refer to Chapter 7 Drive Status Indicator, in the MAN-G-Panel Mounted Drives Hardware manual.

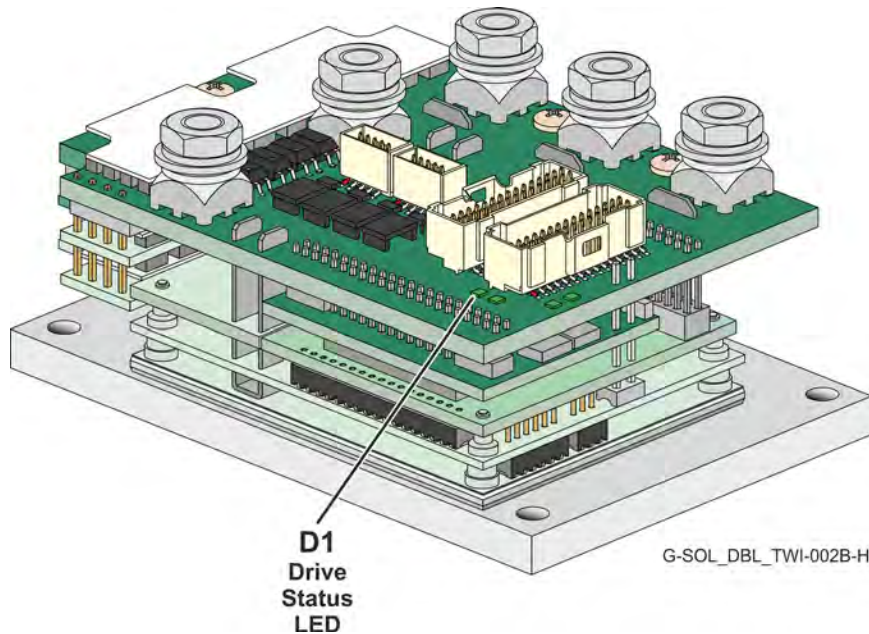

Drive Status Indicator - EtherCAT

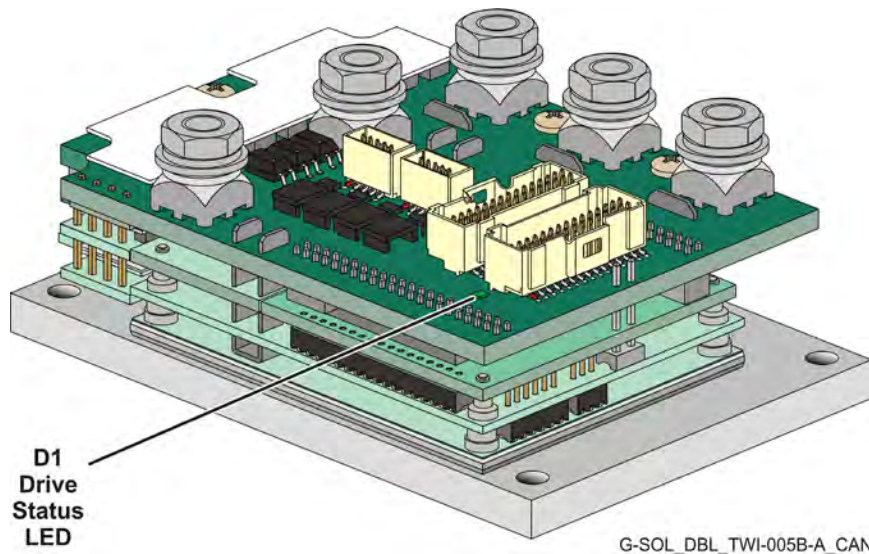

Figure 10: Drive Status Indicator - CAN

The red/green dual LED is used for immediate indication of the following states:

- **Initiation state:** In this state the LED indicates whether the drive is in the boot state (blinking red) or in the operational state (steady red).
- **Working state:** In this state the LED indicates whether the drive is in an amplifier failure state (red) or is ready to enable the motor (green).



8.3. J10 VL and Feedback Connector

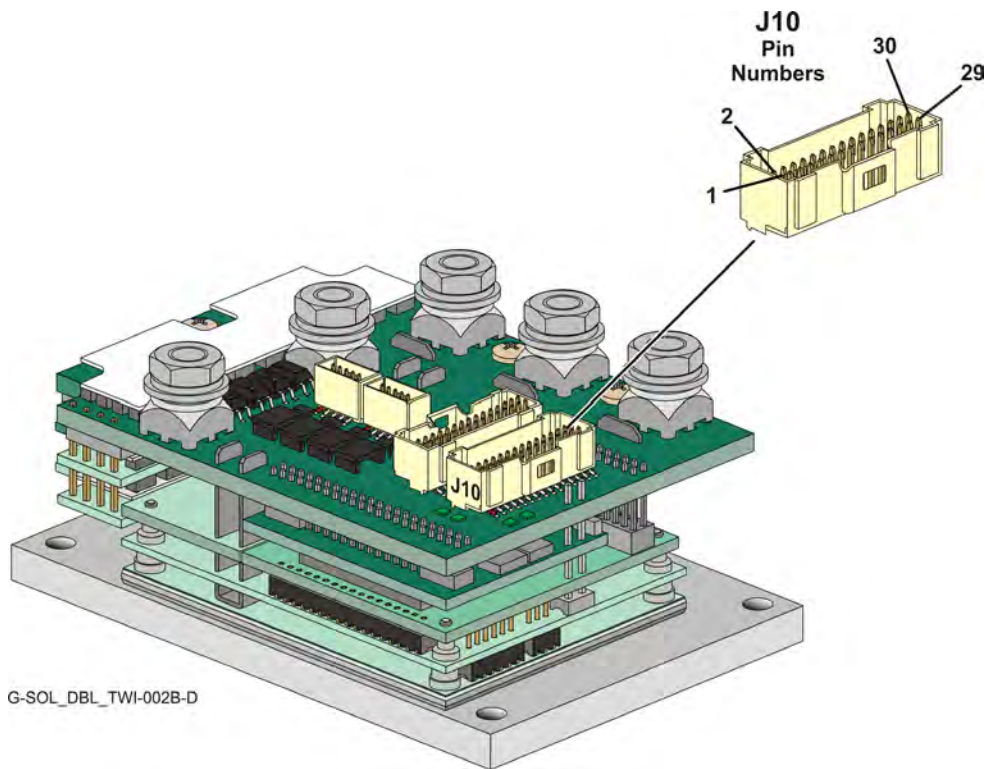

J10 VL & Feedback Connector

Feedback A/B/C, Digital Halls – see Section 9.2 in the manual: MAN-G-Board Level Modules Hardware Manual.

The following table describes the J10 VL and Feedback connections to the 2 x 15 pins female connector.

Pin J10	Signal	Function
1	PortA_ENC_A+ / ABS_CLK+	Channel A+ / Abs encoder clock +
2	PortB_ENC_A-	Port B Channel A-
3	PortA_ENC_A- / ABS_CLK-	Channel A- / Abs encoder clock -
4	PortB_ENC_A+	Port B Channel A+
5	PortA_ENC_B+ / ABS_DATA+	Channel B+ / Abs encoder data +
6	PortB_ENC_B-	Port B Channel B-
7	PortA_ENC_B- / ABS_DATA-	Channel B- / Abs encoder data -
8	PortB_ENC_B+	Port B Channel B+
9	PortA_ENC_INDEX+	Index+
10	PortB_ENC_INDEX-	Port B Index-



Pin J10	Signal	Function
11	PortA_ENC_INDEX-	Index-
12	PortB_ENC_INDEX+	Port B Index+
13	HA	Hall sensor A
14	PortC_ENCO_A-	Buffered Channel A- output / Pulse- / PWM-
15	HB	Hall sensor B
16	PortC_ENCO_A+	Buffered Channel A+ output/Pulse+/PWM+
17	HC	Hall sensor C
18	PortC_ENCO_B-	Buffered Channel B- output / Dir-
19	+5V	Encoder +5V supply with a total allowable maximum consumption of 200mA using Pins 19 and 26.
20	PortC_ENCO_B+	Buffered Channel B+ output / Dir+
21	COMRET	Common return
22	PortC_ENCO_Index-	Buffered Channel INDEX- output
23	COMRET	Common return
24	PortC_ENCO_Index+	Buffered Channel INDEX+ output
25	COMRET	Common return
26	+5V	Encoder +5V supply with a total allowable maximum consumption of 200mA using Pins 19 and 26.
27	COMRET	Common return
28	COMRET	Common return
29	VL-	Control 24V supply return
30	VL+	Control 24V supply

Table 5: Connector J10 – VL & Feedback



8.3.1. Port A

Refer to section 10.3 in the MAN-G-Board Level Modules Hardware Manual for further details of the Port A connections.

8.3.1.1. Incremental Encoder

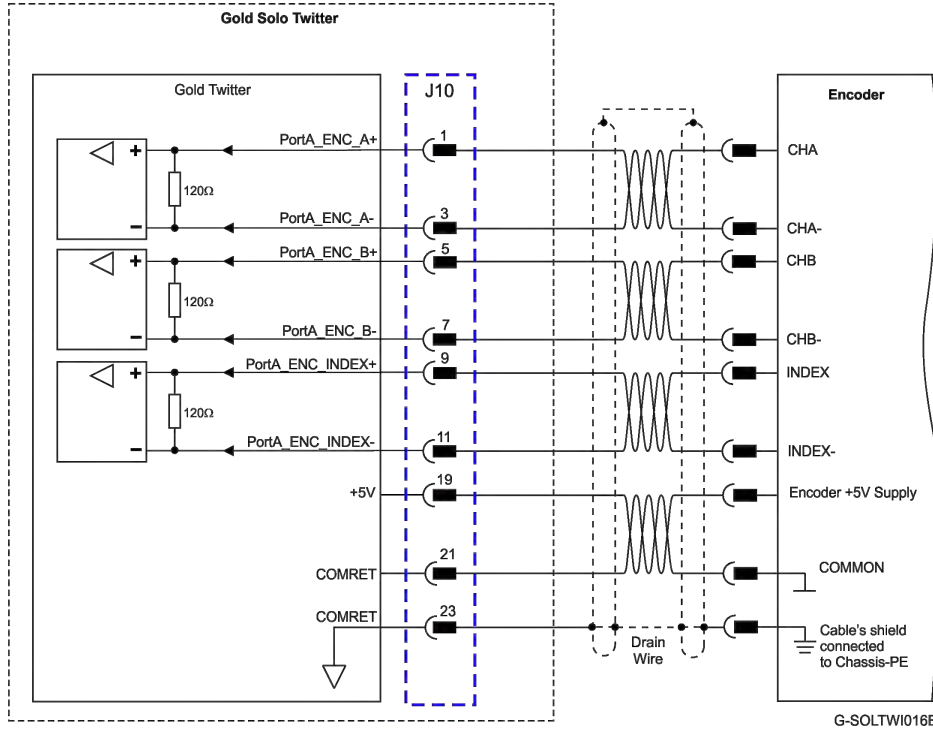

Figure 11: Port A Incremental Encoder Input – Recommended Connection Diagram

8.3.1.2. Absolute Serial Encoder

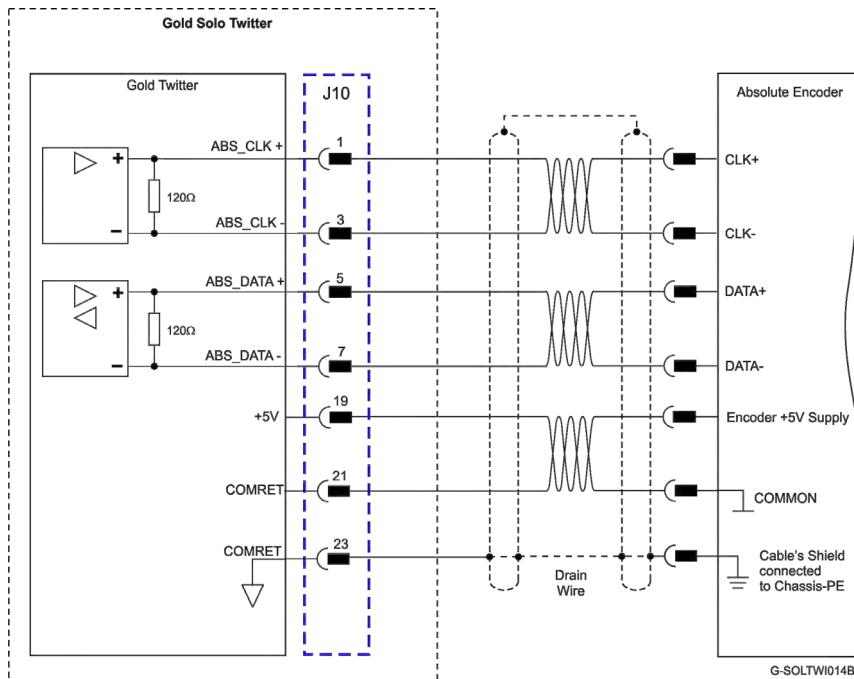

Figure 12: Absolute Serial Encoder – Recommended Connection Diagram for Sensors Supporting Data/Clock (e.g., Biss / SSI / EnDAT, etc.)

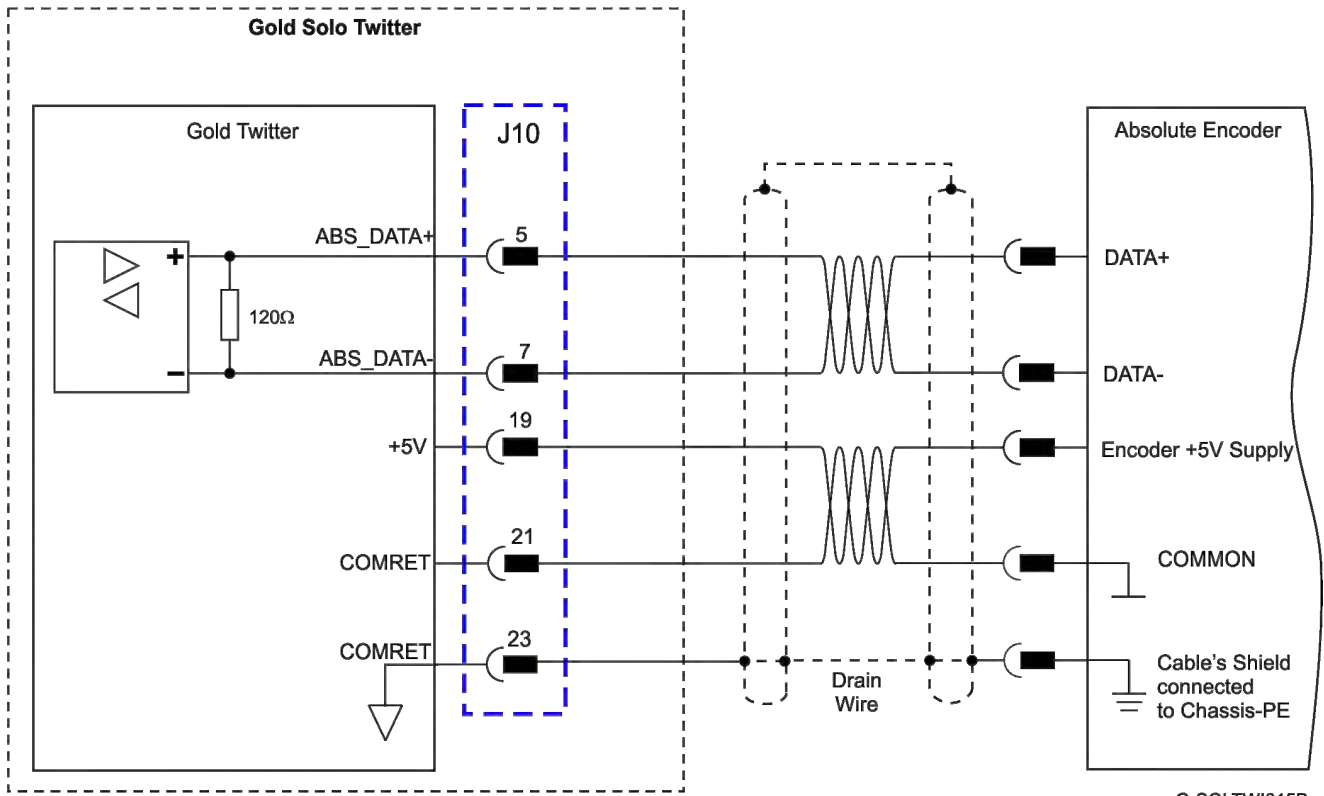

Figure 13: Absolute Serial Encoder – Recommended Connection Diagram for Sensors Supporting Data Line Only (NRZ types, e.g., Panasonic / Mitutoyo / etc.)



8.3.1.3. Hiperface

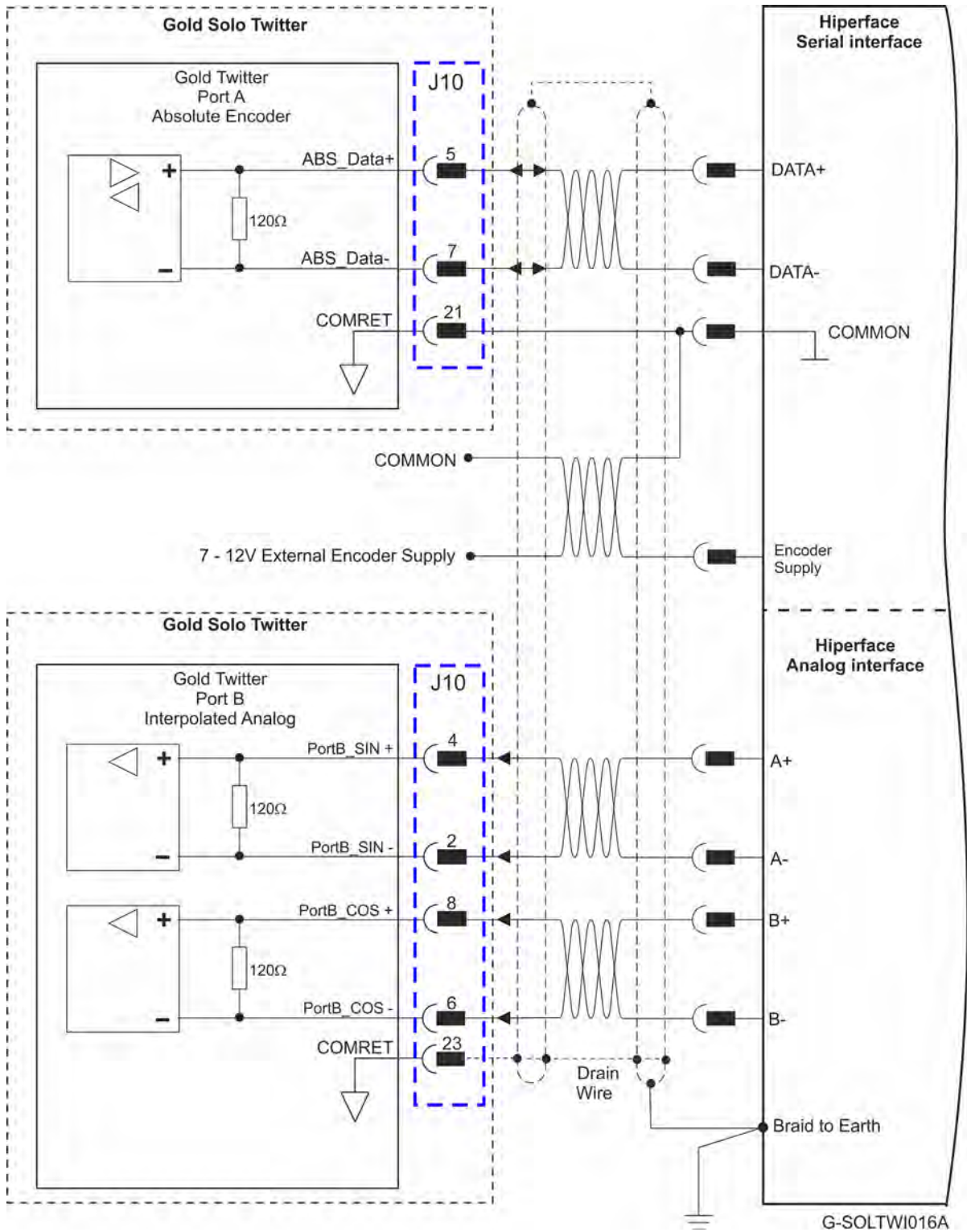

Figure 14: Absolute Serial Encoder – Recommended Connection Diagram for Stegmann Hiperface

Note: When the Hiperface protocol is used, the RS-232 connection is not available



8.3.1.4. Hall Sensors

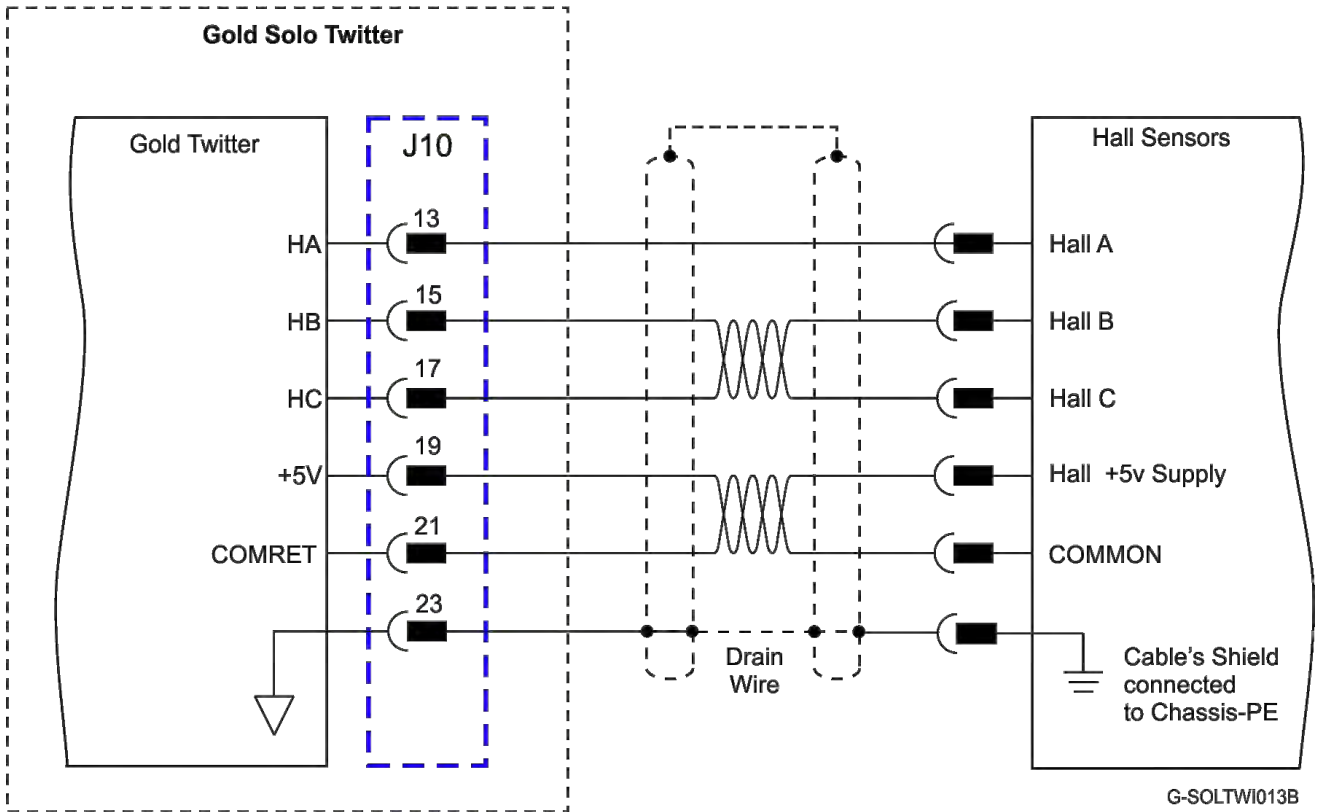

Figure 15: Hall Sensors Connection Diagram



8.3.2. Port B

Refer to section 10.4 in the MAN-G-Board Level Modules Hardware Manual for further details of the Port B connections.

8.3.2.1. Incremental Encoder

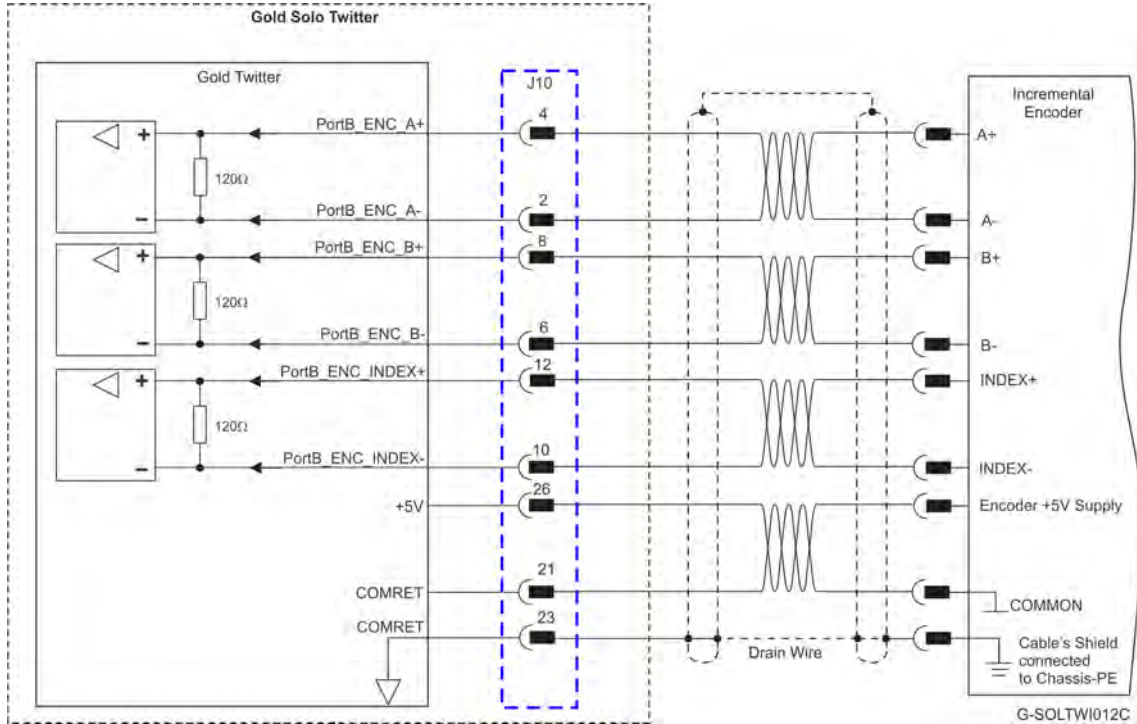

Figure 16: Port B Incremental Encoder Input – Recommended Connection Diagram

8.3.2.2. Interpolated Analog Encoder

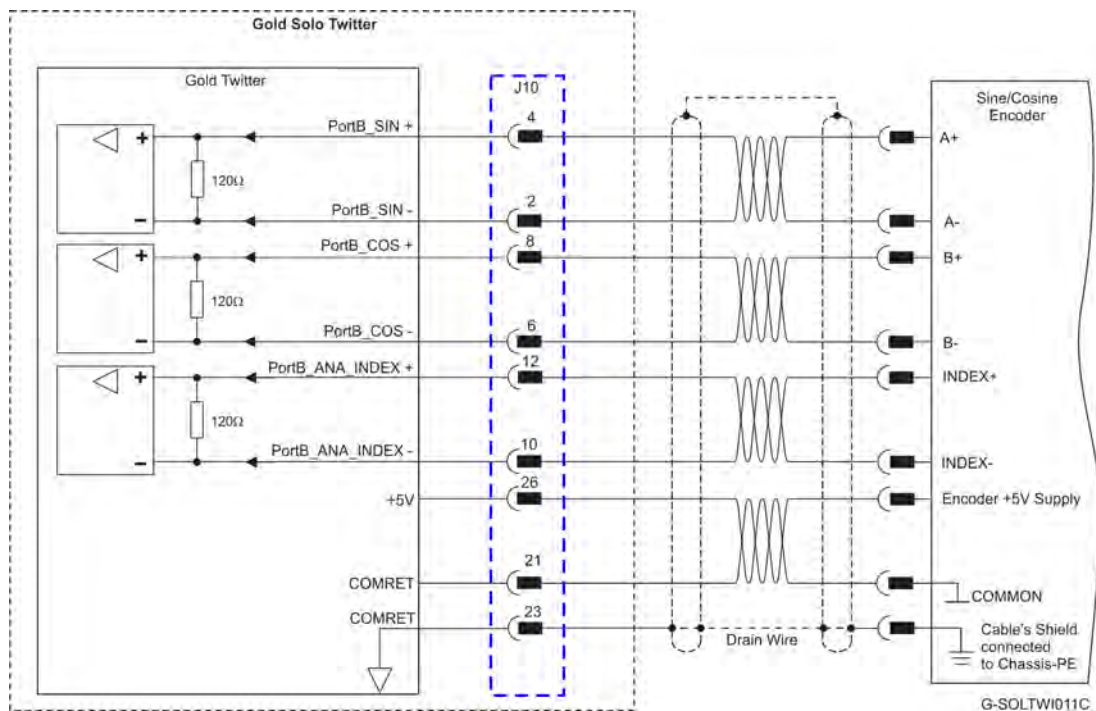

Figure 17: Port B - Interpolated Analog Encoder Connection Diagram



8.3.2.3. Resolver

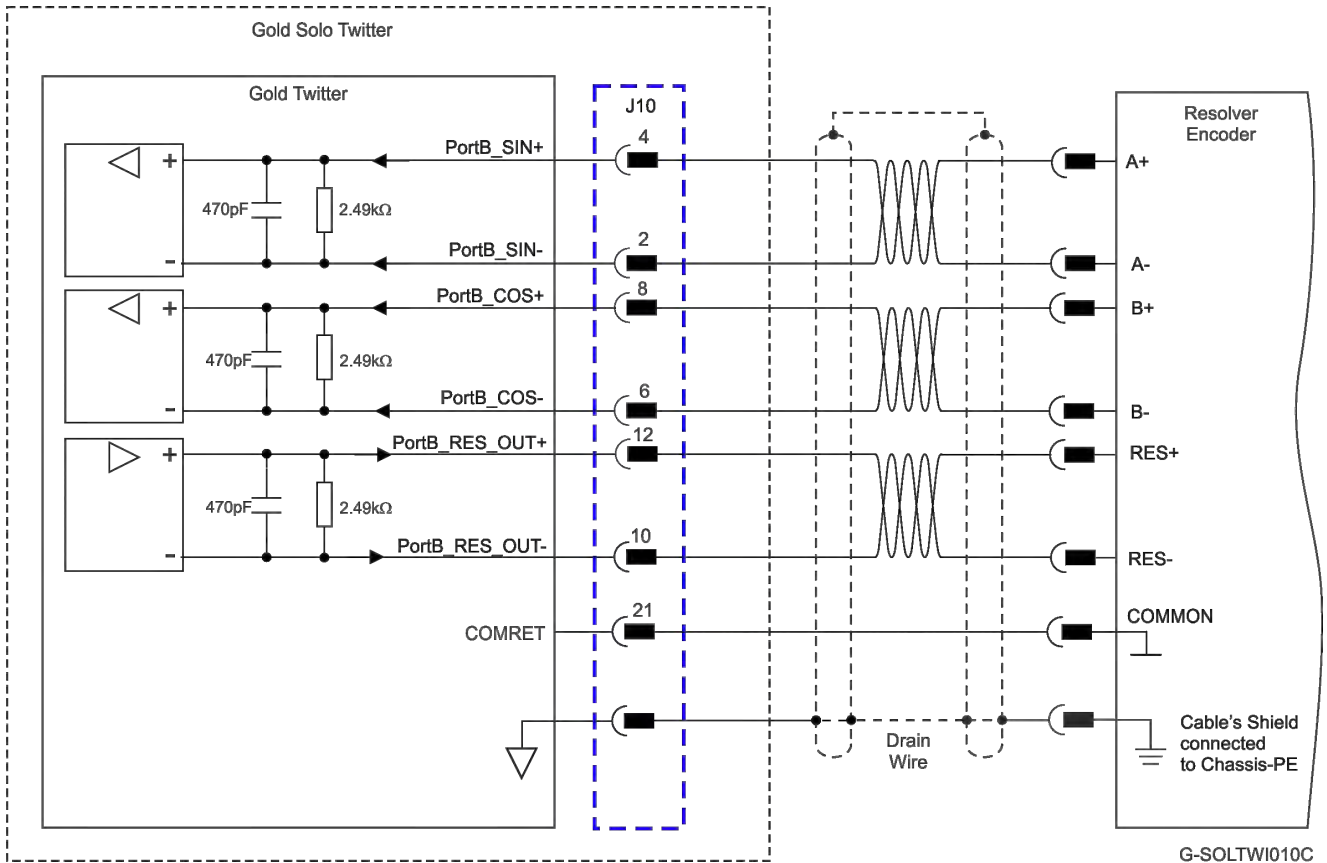

Figure 18: Port B – Resolver Connection Diagram



8.3.3. Port C – Emulated Encoder Output (J10)

See Section 10.5 in the manual: MAN-G-Board Level Modules Hardware Manual for further details of Port C.

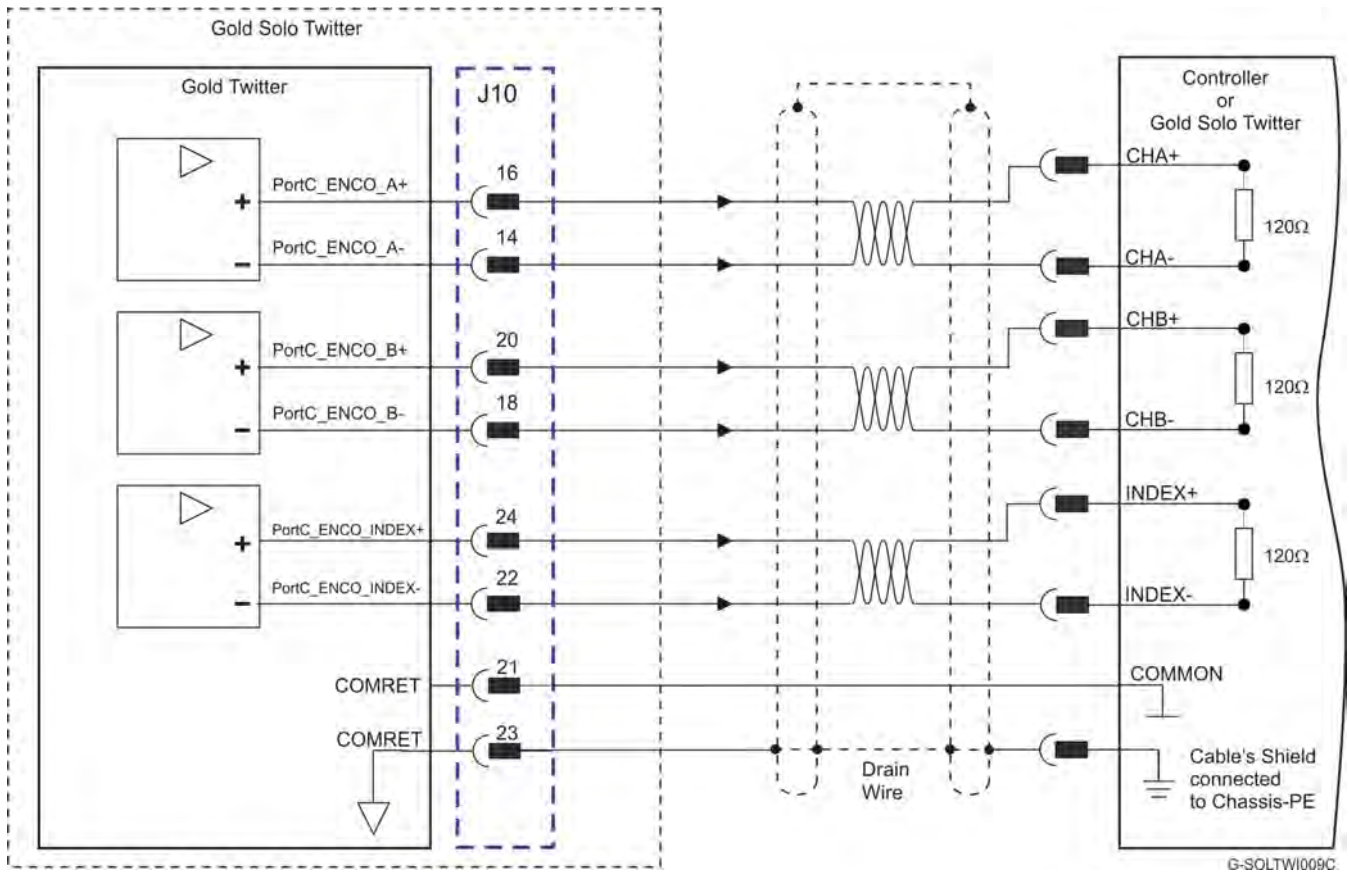
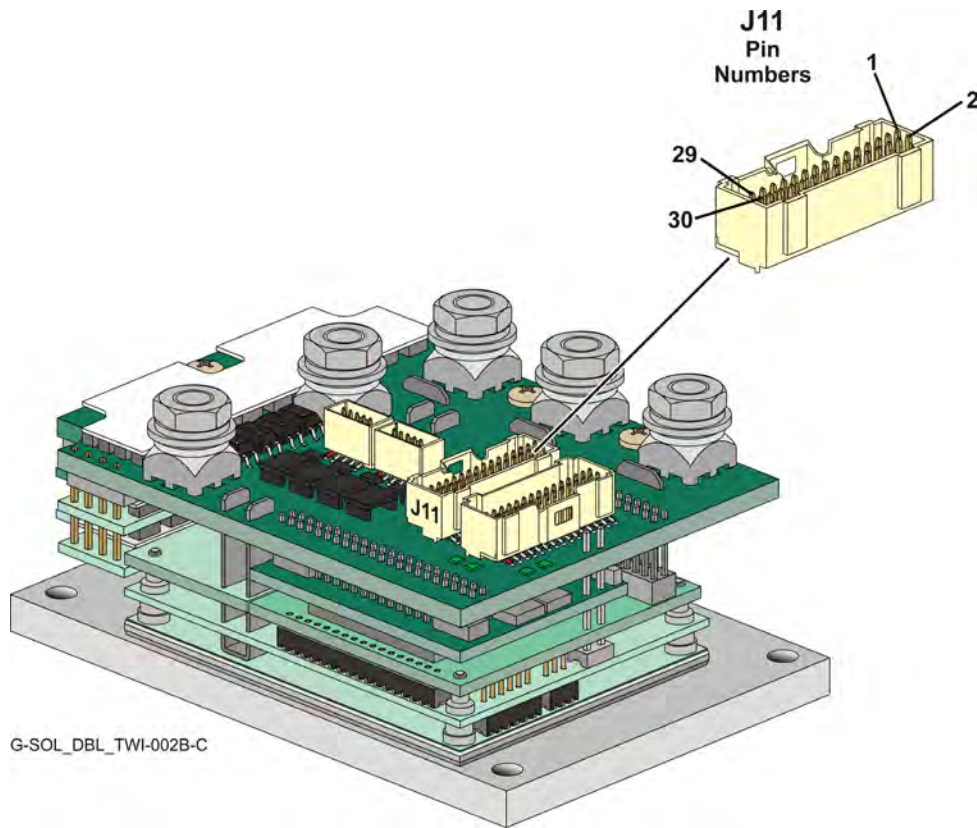

Figure 19: Emulated Encoder Differential Output – Recommended Connection Diagram



8.4. J11 I/O and Communication Connector



G-SOL_DBL_TWI-002B-C

J11 I/O and Communication Connector

Pin J11	Signal	Function
1	IN1	High speed programmable digital input 1 (opto isolated from control COMRET)
2	IN2	High speed programmable digital input 2 (opto isolated from control COMRET)
3	IN3	High speed programmable digital input 3 (opto isolated from control COMRET)
4	IN4	High speed programmable digital input 4 (opto isolated from control COMRET)
5	IN5	High speed programmable digital input 5 (opto isolated from control COMRET)
6	IN6	High speed programmable digital input 6 (opto isolated from control COMRET)
7	INRET	Din return
8	INRET	Din return



Pin J11	Signal	Function
9	OUT1	Programmable output 1 (opto isolated from control COMRET)
10	OUT2	Programmable output 2 (opto isolated from control COMRET)
11	OUT3	Programmable output 3 (opto isolated from control COMRET)
12	OUT4	Programmable output 4 (opto isolated from control COMRET)
13	OUTRET	D _{out} return
14	OUTRET	D _{out} return
15	STO1	STO 1 input opto isolated from control COMRET
16	STO2	STO 2 input opto isolated from control COMRET
17	STO_RET	STO signal return. The two digital STO inputs are optically isolated from the other parts of the drive, and share one return line.
18	STO_RET	STO signal return. The two digital STO inputs are optically isolated from the other parts of the drive, and share one return line.
19	COMRET	Common return
20	GPIO5 ANALOG IN	GPIO5 Analog input
21	ANALOG1+	Analog input 1
22	ANALOG1-	Analog input 1 complement
23	COMRET	Common return
24	COMRET	Common return
25	RS-232_TX	RS-232 Transmit
26	RS-232_RX	RS-232 Receive
27	USB_VBUS	USB VBUS detector (Only for EtherCAT version)
28	COMRET	Common return
29	USB D+	USB _P line (Only for EtherCAT version)
30	USB D-	USB _N line (Only for EtherCAT version)

Table 6: I/O, STO, Analog, RS-232, and USB Connector

STO (safety): For full details on STO, see Chapter 9 in the in the MAN-G-Board Level Modules Hardware manual for full details.



8.4.1. Digital Inputs

8.4.1.1. Source PLC Voltage Level Digital Input

Feature	Details
Standard	Isolated PLC source Conforming to IEC 61131-2
Input current	$I_{in} = (V_{in} - 7.4) / 4.99 \text{ Kohm}$ $I_{in} = 920 \text{ uA @ } V_{in} = 12 \text{ V}$ $I_{in} = 4.5 \text{ mA @ } V_{in} = 30 \text{ V}$
High-level input voltage	$12 \text{ V} < V_{in} < 30 \text{ V}$
Low-level input voltage	$0 \text{ V} < V_{in} < 7 \text{ V}$
Minimum pulse width	$> 250 \text{ } \mu\text{sec}$
Execution time (all inputs): the time from application of voltage on input until execution is complete	$0 < T < 250 \text{ } \mu\text{sec}$
High-speed inputs – 1–6 minimum pulse width, in high-speed mode	$T > 5 \text{ } \mu\text{sec}$ if the input functionality is set to latch/capture (index/strobe). Notes: <ul style="list-style-type: none"> Home mode is high-speed mode and can be used for fast capture and precise homing. Highest speed is achieved when turning on optocouplers.
Capture with differential input Port A, Port B Index	$T > 0.1 \text{ } \mu\text{sec}$ if the differential input functionality is set to touch probe/capture (index/strobe).

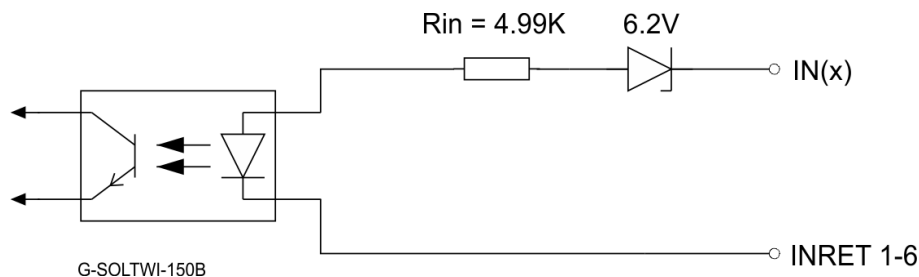
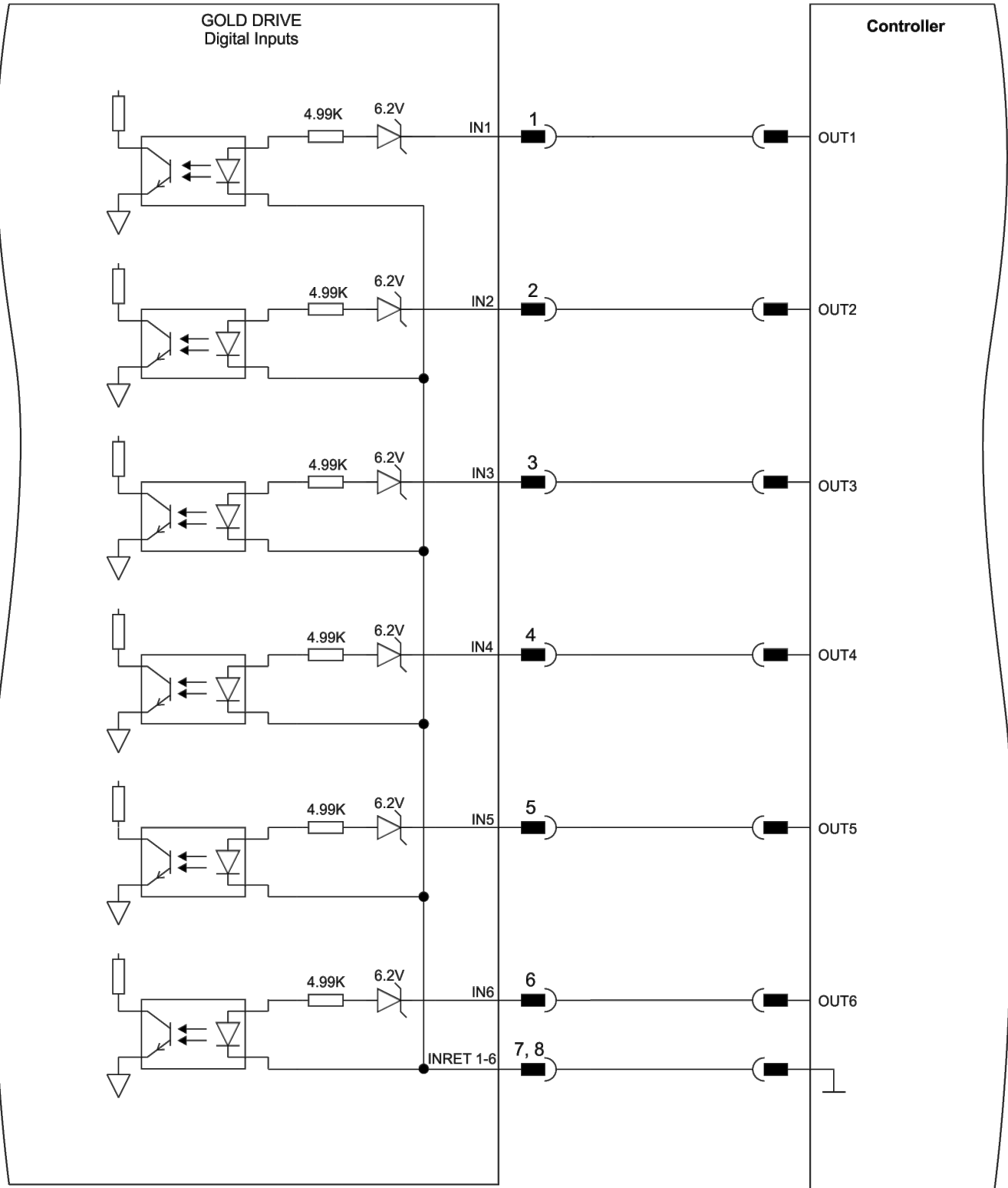

Figure 20: Digital Input PLC Source Schematic



The following are the connection diagram of Digital inputs:



GGEN_PNL038H

Figure 21: Digital Input Connection Diagram Example – Source PLC Option

**8.4.1.2. Sink PLC Voltage Level Digital Input**

Feature	Details
Type of input	Isolated PLC Sink
Input current	$I_{in} = (V_{in} - 7.4) / 4.99K\Omega$ $I_{in} = 920 \mu A @ V_{in} = 12 V$ $I_{in} = 4.5 mA @ V_{in} = 30 V$
High-level input voltage	$12 V < V_{in} < 30 V$
Low-level input voltage	$0 V < V_{in} < 7 V$
Minimum pulse width	$> 250 \mu sec$
Execution time (all inputs): the time from application of voltage on input until execution is complete	$0 < T < 250 \mu sec$
High-speed inputs – 1–6 minimum pulse width, in high-speed mode	$T > 5 \mu sec$ if the input functionality is set to latch/capture (index/strobe). Notes: <ul style="list-style-type: none"> Home mode is high-speed mode and can be used for fast capture and precise homing. Highest speed is achieved when turning on optocouplers.
Capture with differential input Port A, Port B Index	$T > 0.1 \mu sec$ if the differential input functionality is set to touch probe/capture (index/strobe).
<p style="text-align: center;">Figure 22: Digital Input Sink PLC Schematic</p>	

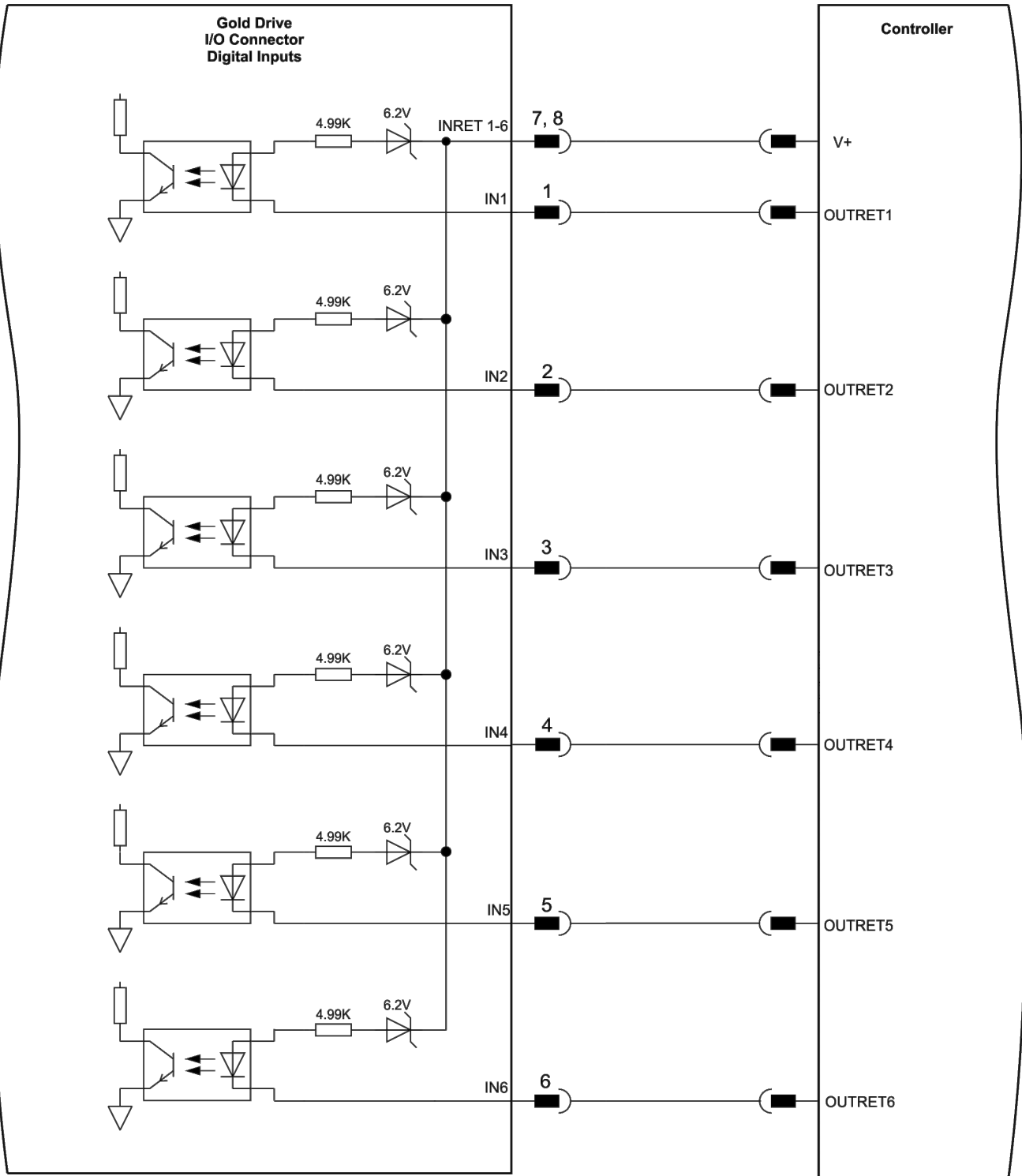

GGEN_PNL039H

Figure 23: Digital Input Sink Mode Example – PLC voltage level Connection Diagram



8.4.1.3. Source 5V Logic Level Digital Input

Feature	Details
Type of input	Optically isolated
Input current for all inputs	$I_{in} = 3.8 \text{ mA} @ V_{in} = 5 \text{ V}$
High-level input voltage	$3.0 \text{ V} < V_{in} < 10 \text{ V}, 5 \text{ V typical}$
Low-level input voltage	$0 \text{ V} < V_{in} < 0.8 \text{ V}$
Minimum pulse width	$> 250 \mu\text{sec}$
Execution time (all inputs): the time from application of voltage on input until execution is complete	$0 < T < 250 \mu\text{sec}$
High-speed inputs – 1–6 minimum pulse width, in high-speed mode	<p>$T > 5 \mu\text{sec}$ if the input functionality is set to latch/capture (index/strobe).</p> <p>Notes:</p> <p>Home mode is high-speed mode and can be used for fast capture and precise homing.</p> <p>Highest speed is achieved when turning on optocouplers.</p>

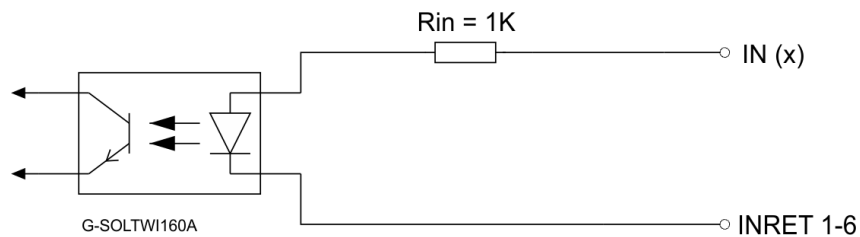
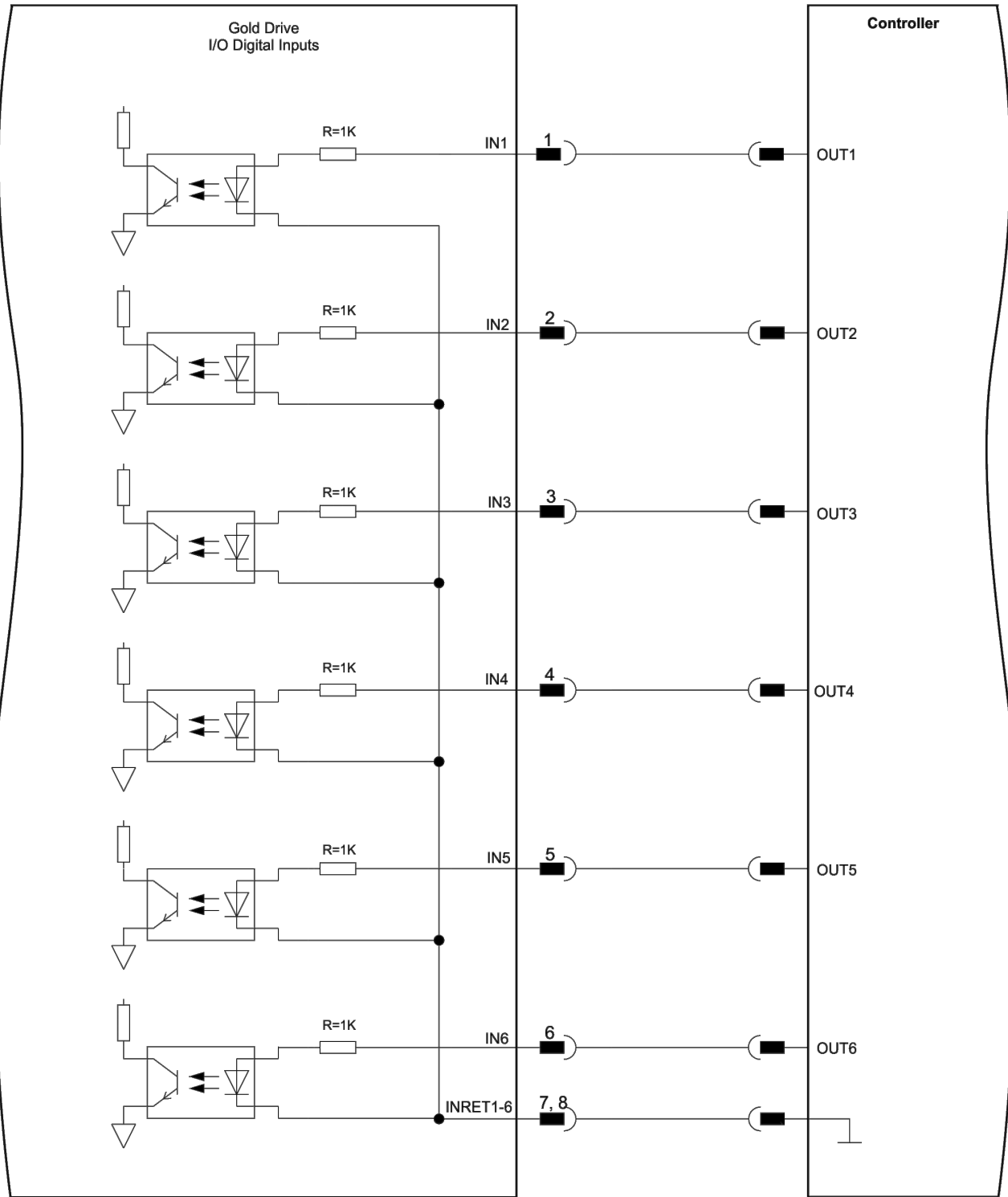

Figure 24: Digital Input 5V Logic Schematic



GGEN_MOLEX037J

Figure 25: Digital Input Source 5V Logic Mode Connection Diagram



8.4.2. Digital Outputs

8.4.2.1. Source PLC Voltage Level Digital Output

Feature	Details
Type of output	Optically isolated PLC source
Supply output (VDD)	12V to 30V (typically 24V)
Max. output current $I_{out (max)} (V_{out} = High)$	$I_{out (max)} \leq 30 \text{ mA}$
Collector Emitter saturation voltage	1V
T_{on} (Time from low to high) If $V_{dd} = 24V$	< 15usec
T_{off} (Time from high to Low)	< 250usec
R_L	The external R_L must be selected to limit output current to no more than 30 mA. $R_L = \frac{VDD - 1}{I_{out (max)}}$
Executable time	$0 < T < 250 \mu\text{sec}$
<p>Figure 26: Digital Photodarlington Output Schematic – Source Mode PLC Level</p>	

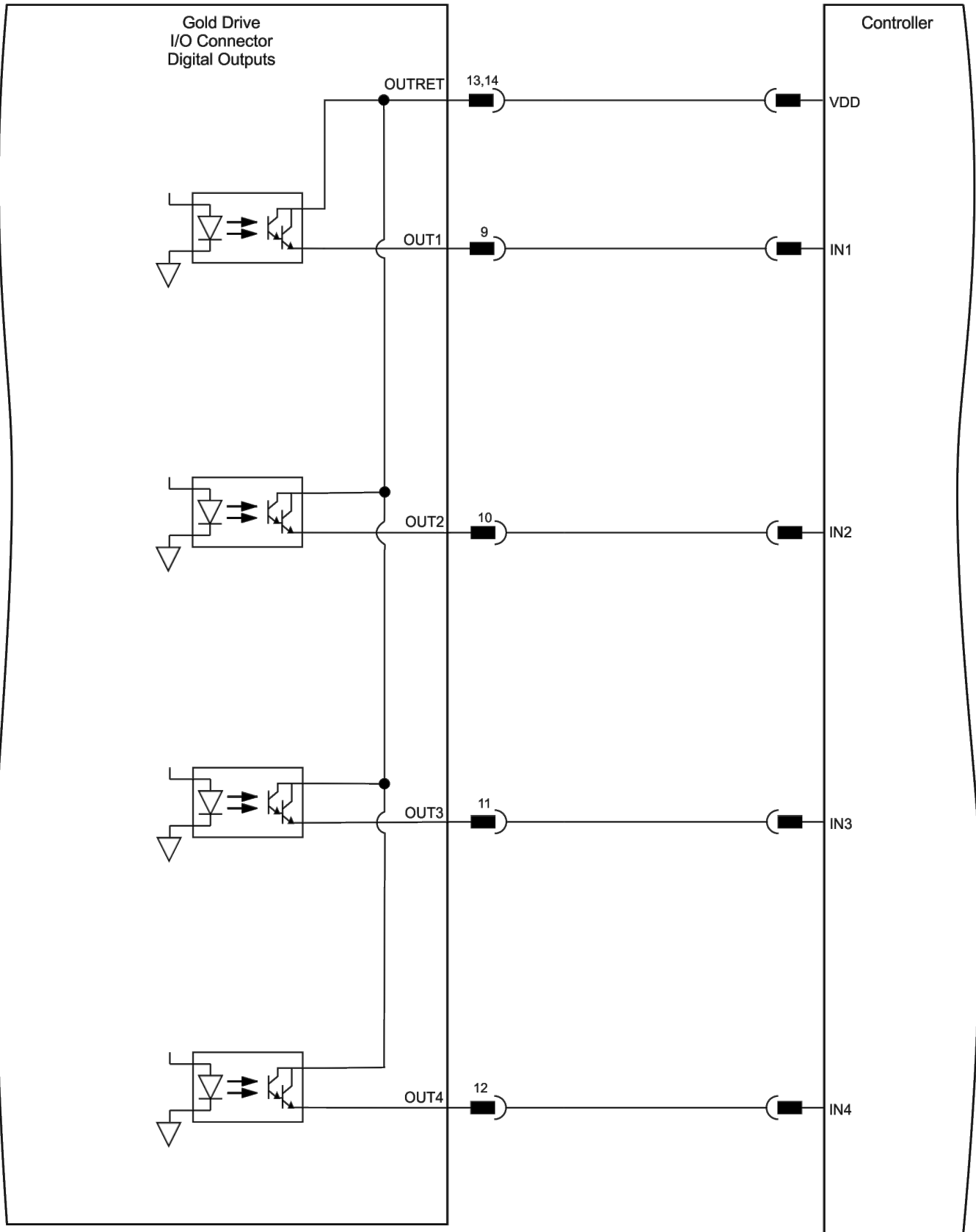

G-SOLTWI134A

Figure 27: Digital Output Connection Diagram Example – Source PLC Option



8.4.2.2. Sink PLC Voltage Level Digital Output

Feature	Details
Type of output	Optically isolated PLC Sink
Supply output (VDD)	12V to 30V (Typically 24V)
Max. output current $I_{out} (max) (V_{out} = Low)$	$I_{out} (max) \leq 30 \text{ mA}$
Collector Emitter saturation voltage	1V
T_{on} (Time from low to high) If $V_{dd} = 24V$	< 15usec
T_{off} (Time from high to Low)	< 300usec
R_L	The external R_L must be selected to limit output current to no more than 30 mA. $R_L = \frac{VDD - 1}{I_{out} (max)}$
Executable time	$0 < T < 250 \mu\text{sec}$

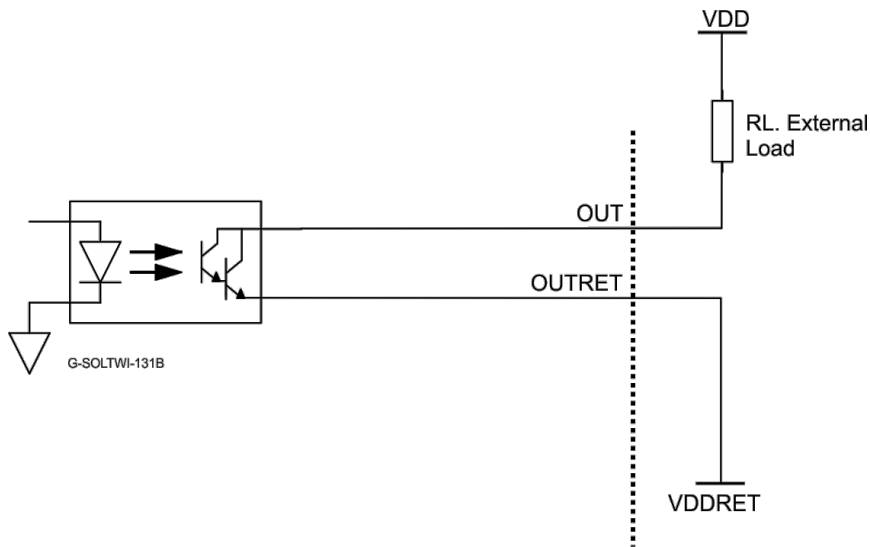
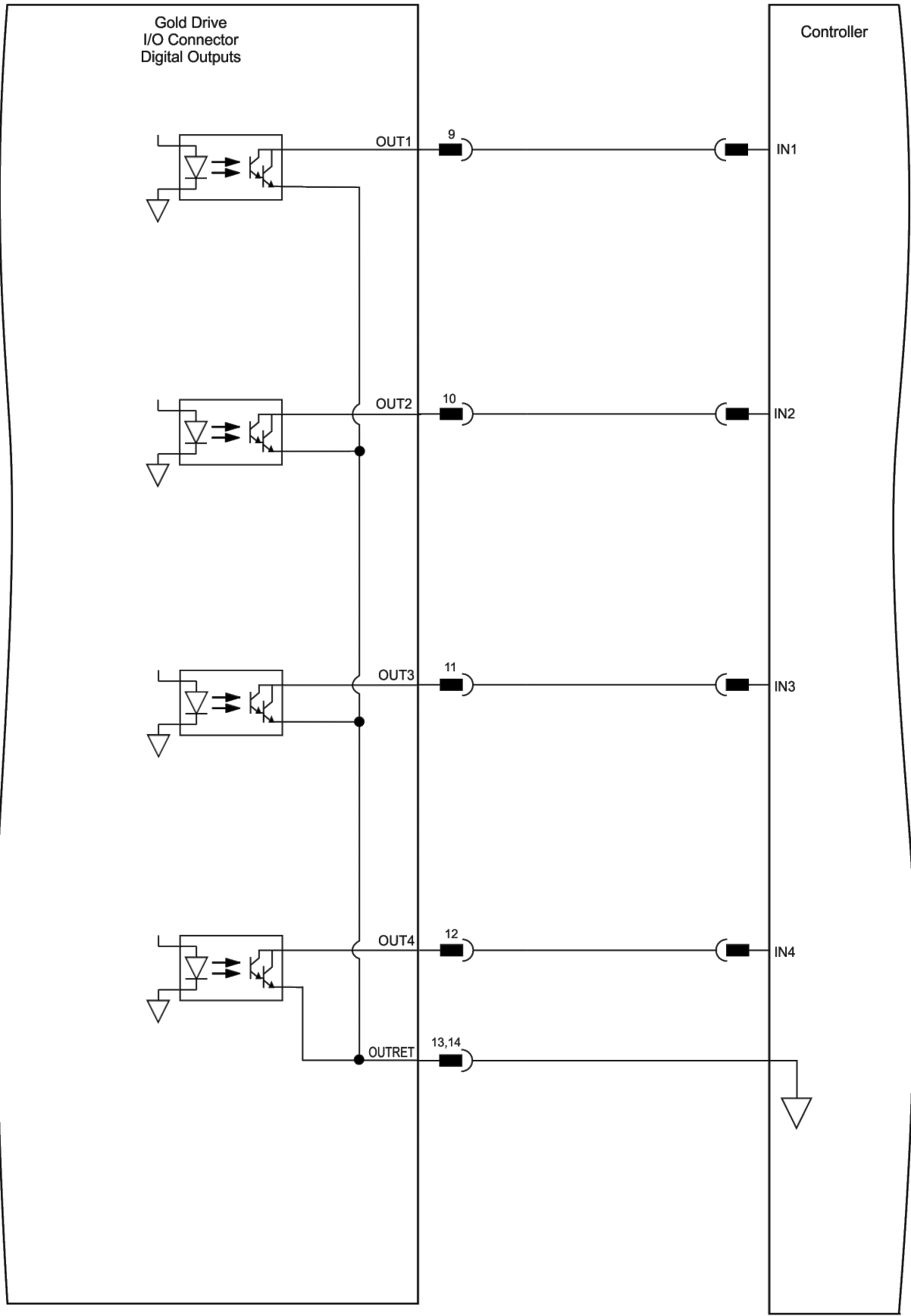

Figure 28: Digital Photodarlington Output Schematic for Sink – PLC level



GGEN_DTYPE040J

Figure 29: Digital Output Connection Diagram Example – Sink PLC Option



8.4.2.3. Digital Outputs Source 5V Logic Mode

Feature	Details
Type of output	Optically isolated 5V Logic source
Supply output (VDD)	< 30 V (Typically 5 V)
Max. output current $I_{out} (max) (V_{out} = High)$	$I_{out} (max) \leq 30 \text{ mA}$
Collector Emitter saturation voltage	1V
T_{on} (Time from low to high) If $V_{dd} = 5V$	< 10usec
T_{off} (Time from high to Low)	< 100usec
R_L	The external R_L must be selected to limit output current to no more than 30 mA. $R_L = \frac{VDD - 1}{I_{out} (max)}$
Executable time	$0 < T < 250 \mu\text{sec}$

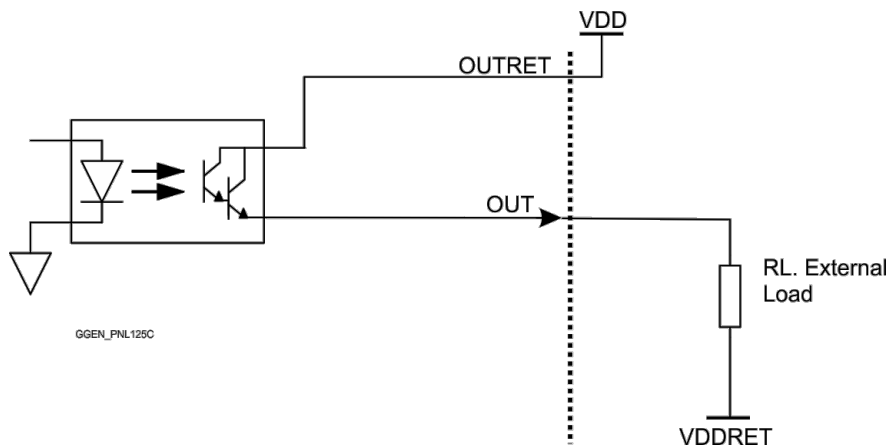
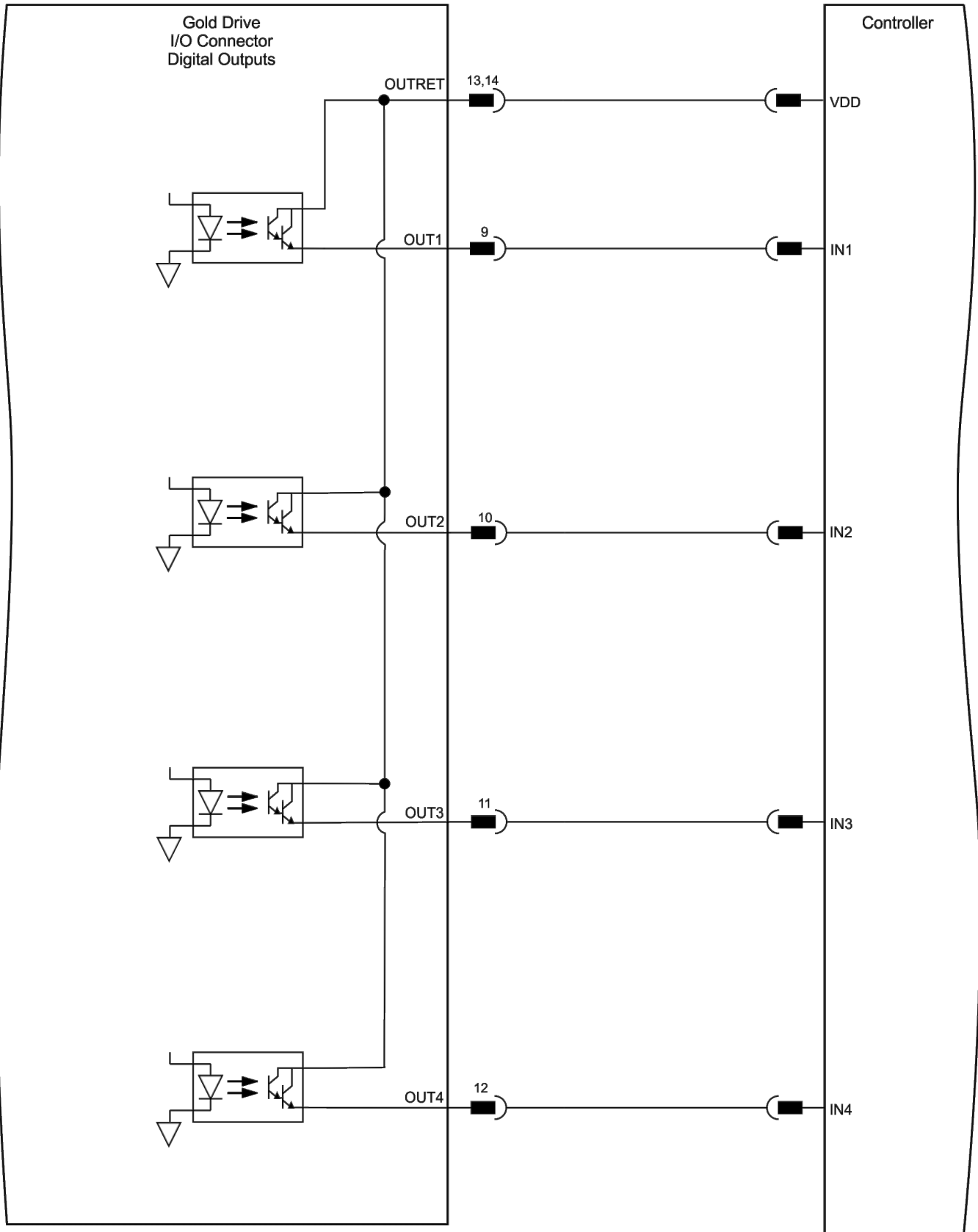

Figure 30: Digital Photodarlington Output Schematic – Source Mode 5V Logic Level



G-SOLTWI134A

Figure 31: Digital Output Connection Diagram Example – Source 5V Logic Option



8.4.3. STO (Safe Torque Off)

For full details on STO, see Chapter 9 in the MAN-G-Board Level Modules Hardware manual.

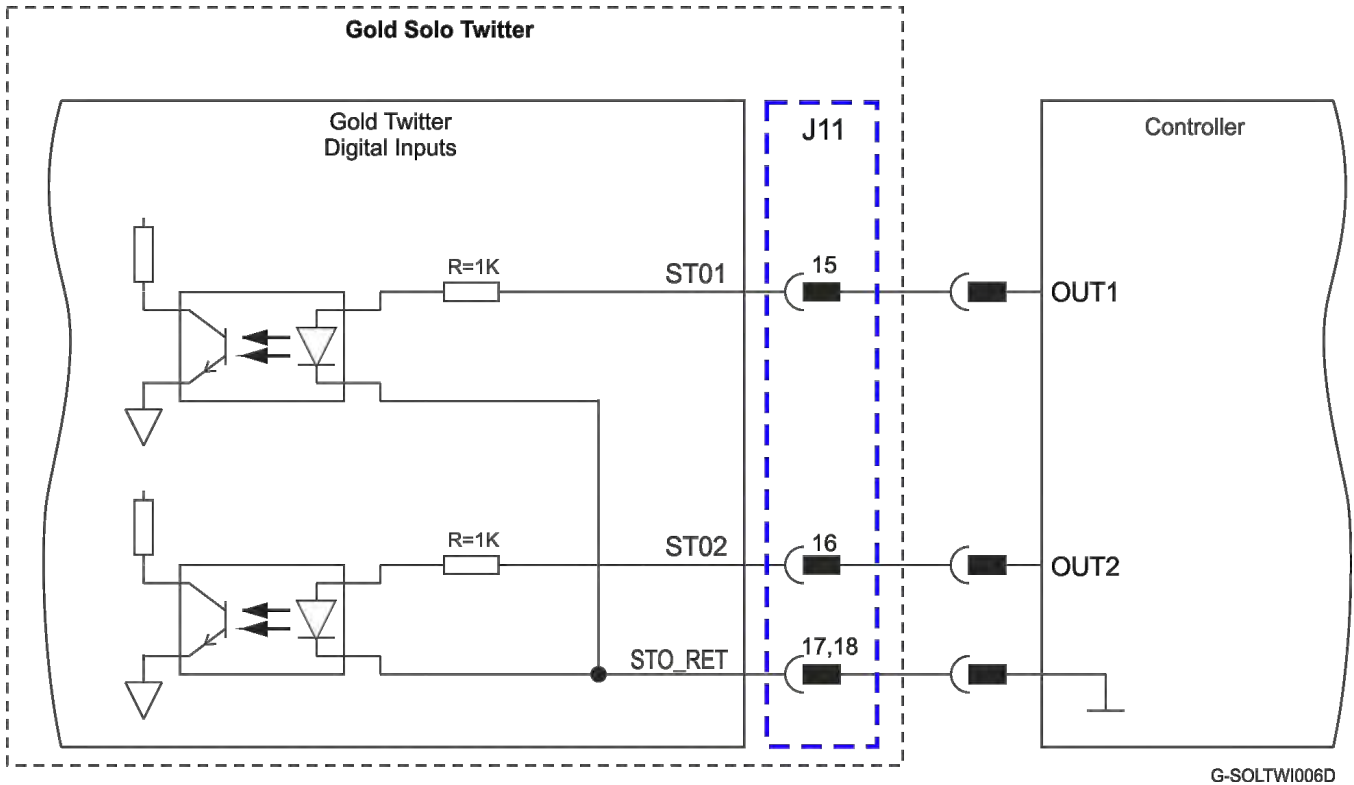

Figure 32: STO Input Connection – 5V Logic

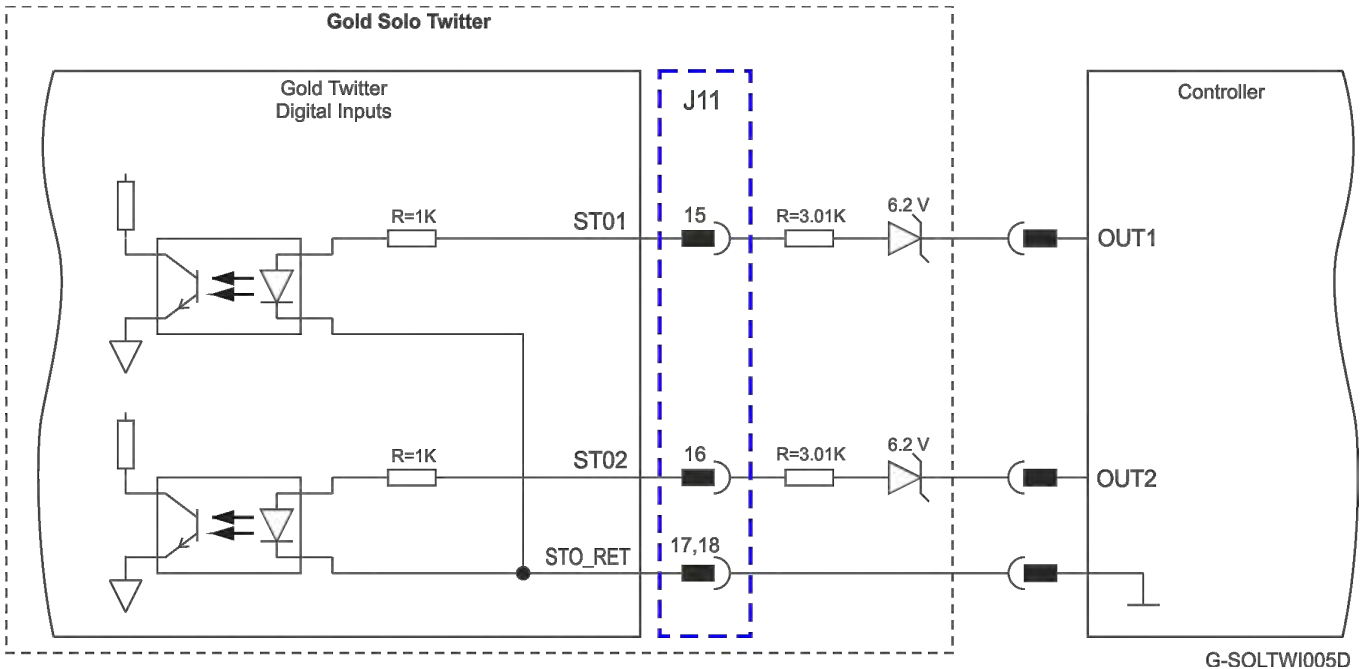

Figure 33: STO Input Connection – PLC (24V Logic)



8.4.4. Analog Input

For full details on Analog Inputs, see section 11.3 in the MAN-G-Board Level Modules Hardware manual.

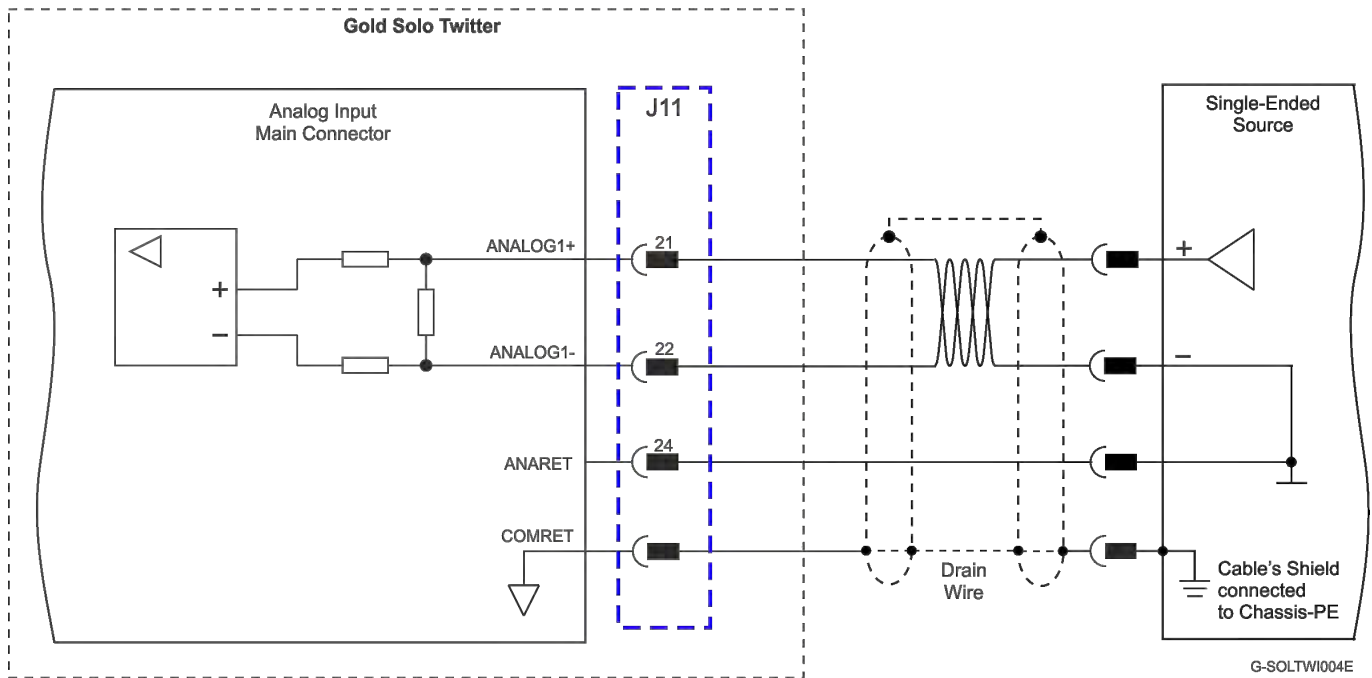

Figure 34: Analog Input



8.4.5. Standard RS-232

Figure 35 describes the Standard RS-232 connection diagram.

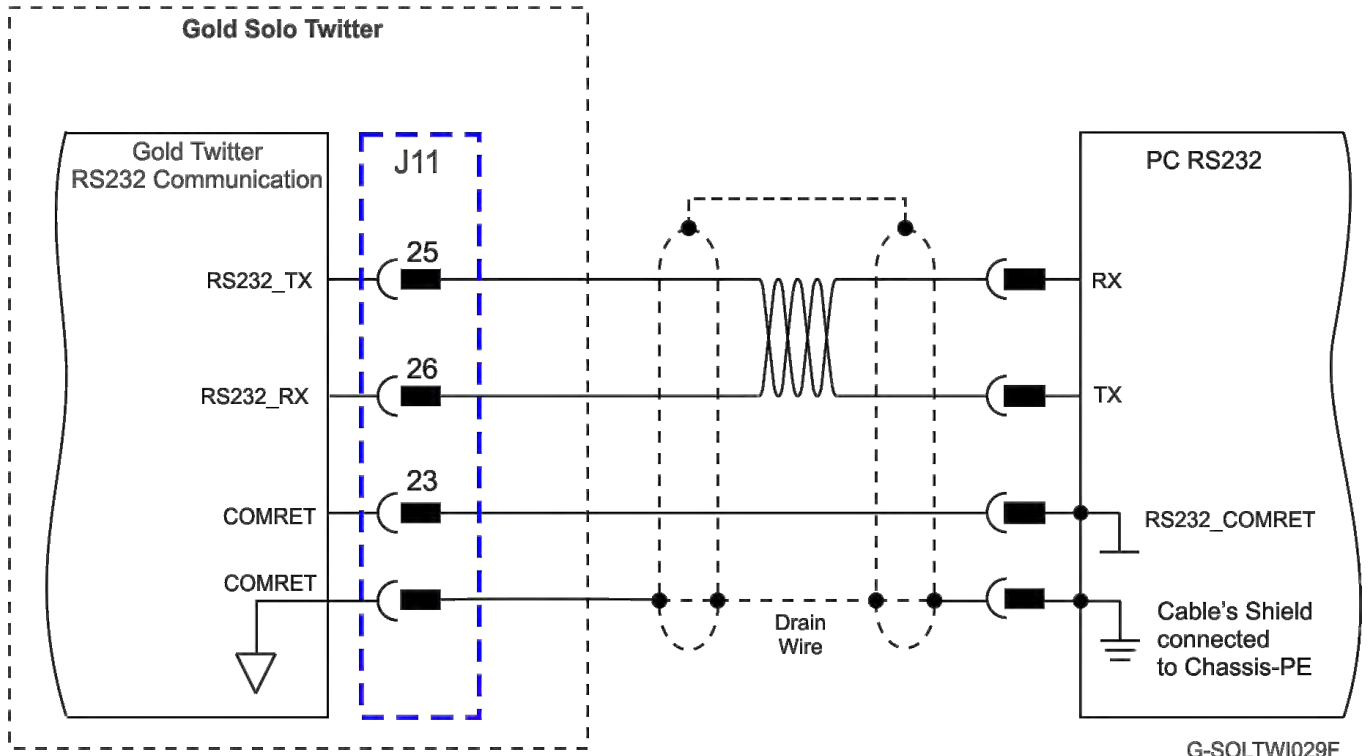

Figure 35: Standard RS-232 Connection Diagram



8.4.6. USB 2.0 Communication (Only for EtherCAT version)

For full details on USB communication, see section 12.1 in the MAN-G-Board Level Modules Hardware manual.

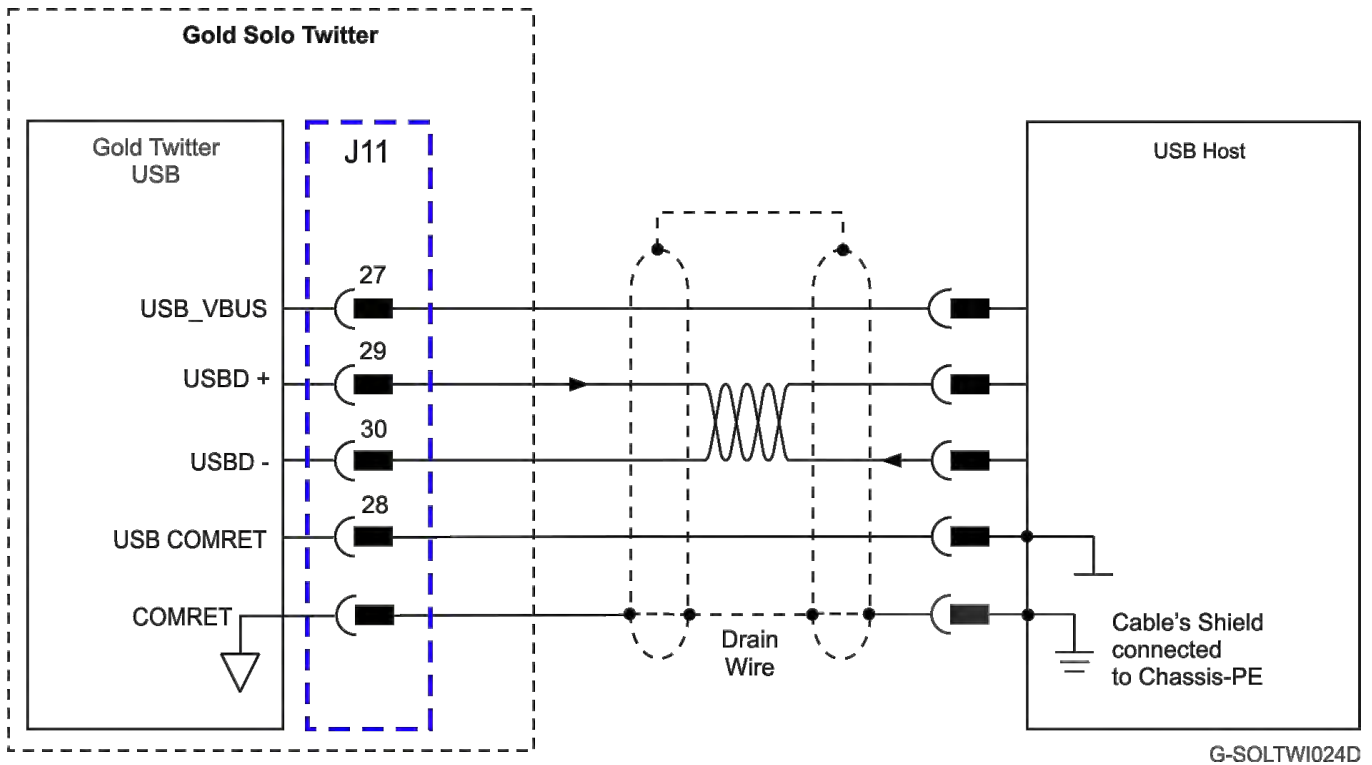

Figure 36: USB Network Diagram



8.5. EtherCAT Communications Version

Fieldbus communications are industrial network protocols for real-time distributed control that allows connection of servo drives. The Gold Solo Twitter B supports the following EtherCAT fieldbus type industrial network protocol:

Fieldbus Type	Product Number
EtherCAT	G-SOLTWIDXXX/YYYEESVD

8.5.1. EtherCAT IN/Ethernet Connector (J17)

Refer to section 12.2 in the MAN-G-Panel Mounted Drives Hardware manual for more details.

Pin (J17)	Signal	Function
1	EtherCAT_IN_TX+/Ethernet_TX+	EtherCAT in/Ethernet transmit +
2	EtherCAT_IN_TX-/Ethernet_TX-	EtherCAT in/Ethernet transmit -
3	EtherCAT_IN_RX+/Ethernet_RX+	EtherCAT in/Ethernet receive +
4	EtherCAT_IN_RX-/Ethernet_RX-	EtherCAT in/Ethernet receive -
5	COMRET	Shield drain wire

Pin Positions	Cable Connector
 <p style="text-align: center;">J17 Pin Numbers</p> <p style="text-align: center;">1 5</p> <p>G-SOL_DBL_TWI-002B-E</p>	 <p style="text-align: right;">Pin #5</p> <p style="text-align: right;">Pin #1</p> <p style="text-align: center;">Ethernet Cable Connector</p>

Table 7: EtherCAT IN / Ethernet Pin Assignments



8.5.2. EtherCAT OUT Connector (J18)

See Section 12.2 in the MAN-G-Panel Mounted Drives Hardware manual for the electrical diagram.

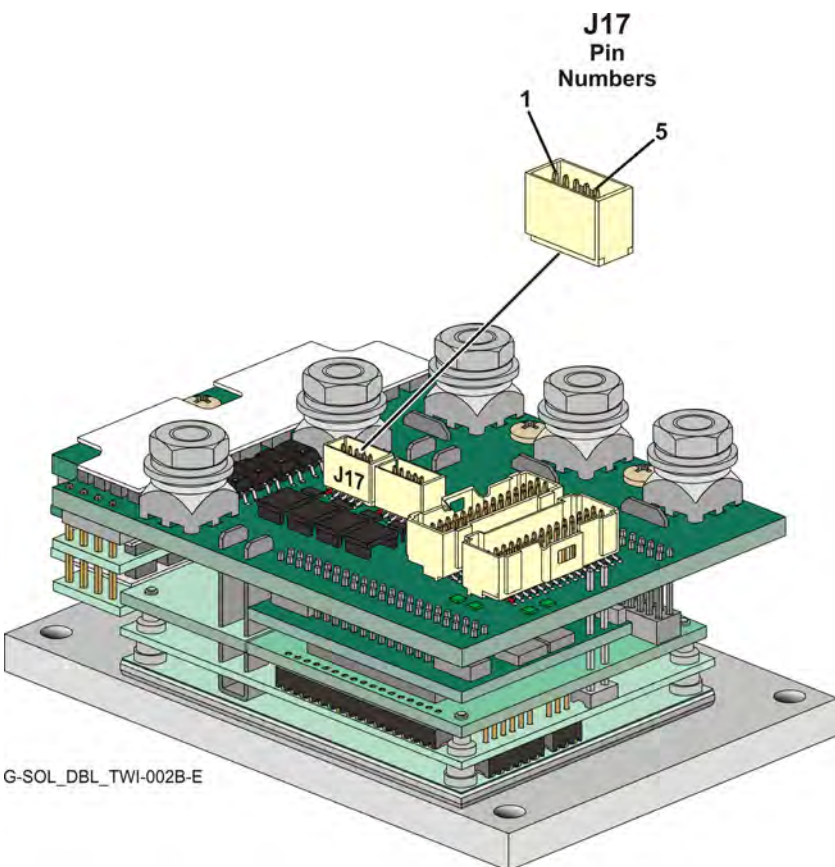
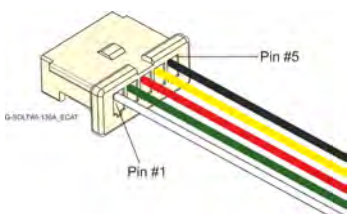
Pin (J18)	Signal	Function
1	EtherCAT_OUT_TX+	EtherCAT out transmit +
2	EtherCAT_OUT_TX-	EtherCAT out transmit -
3	EtherCAT_OUT_RX+	EtherCAT out receive +
4	EtherCAT_OUT_RX-	EtherCAT out receive -
5	COMRET	Shield drain wire

Pin Positions	Cable Connector
 <p>G-SOL_DBL_TWI-002B-F</p>	 <p>Ethernet Cable Connector</p>

Table 8: EtherCAT OUT Pin Assignments



8.5.3. EtherCAT Option

For full details on EtherCAT communication, see Section 12.2 in the in the MAN-G-Board Level Modules Hardware manual.

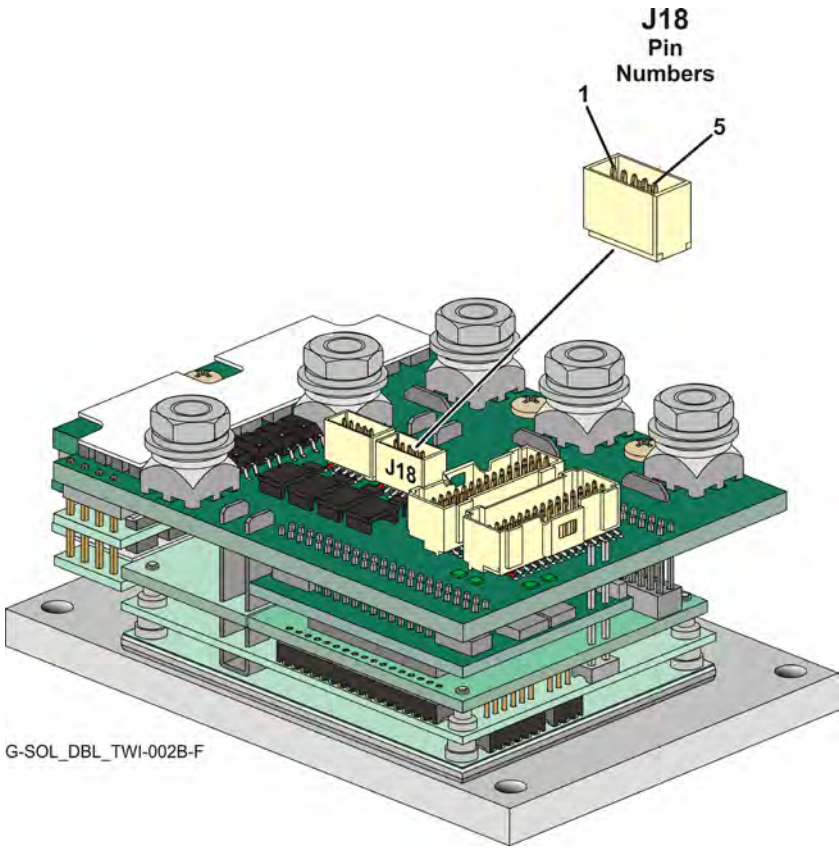
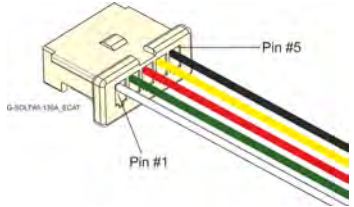
Note: The EtherCAT IN port can be configured to an Ethernet Port.

8.5.3.1. EtherCAT Communication

This section only describes the EtherCAT communication, and the pinout drawing of the connector.



When the EtherCAT is connected and the FoE is in operation, the USB cable connection must be disconnected.

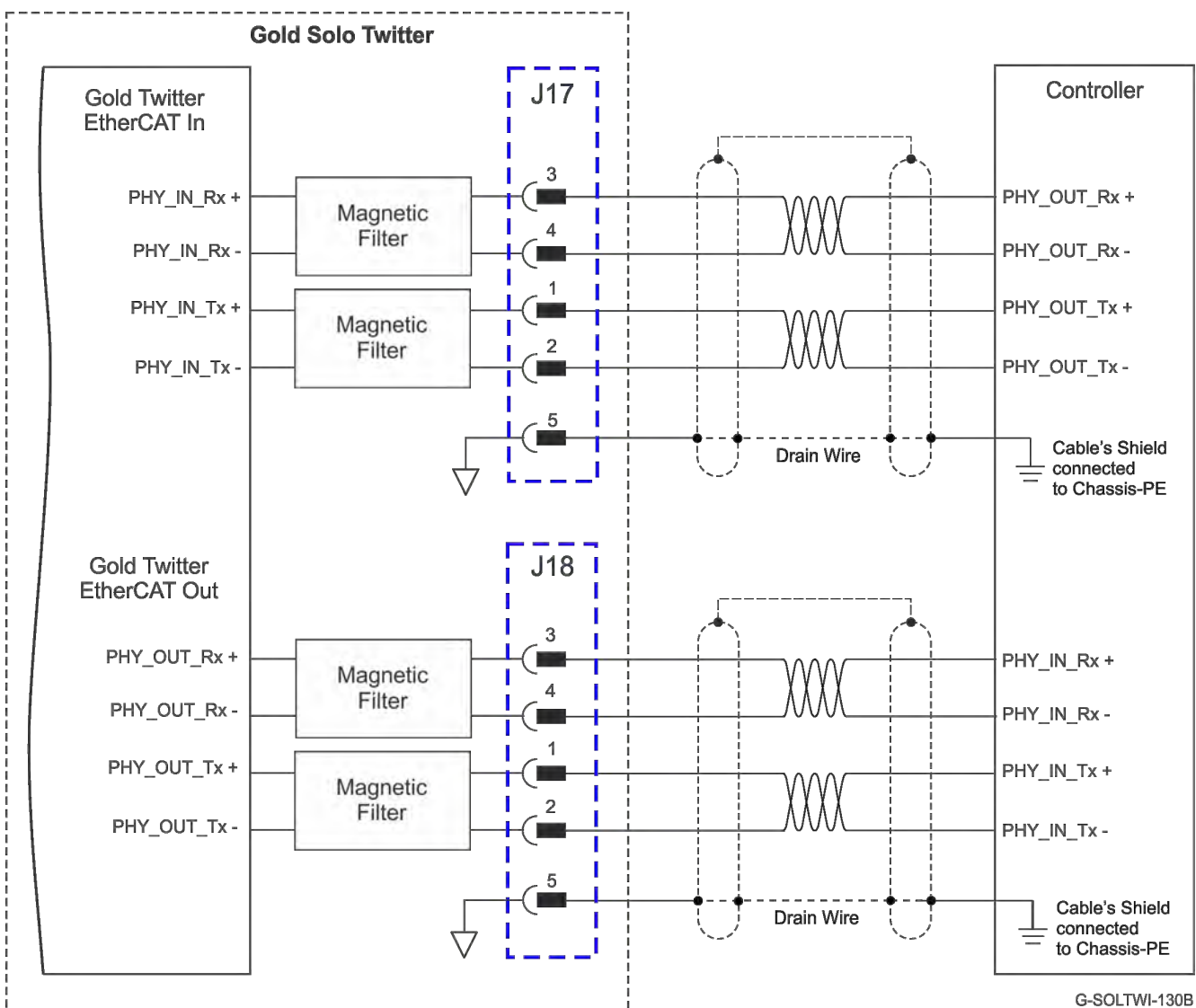

Figure 37: EtherCAT Connection Schematic Diagram



8.5.3.2. EtherCAT Status Indicator (D2)

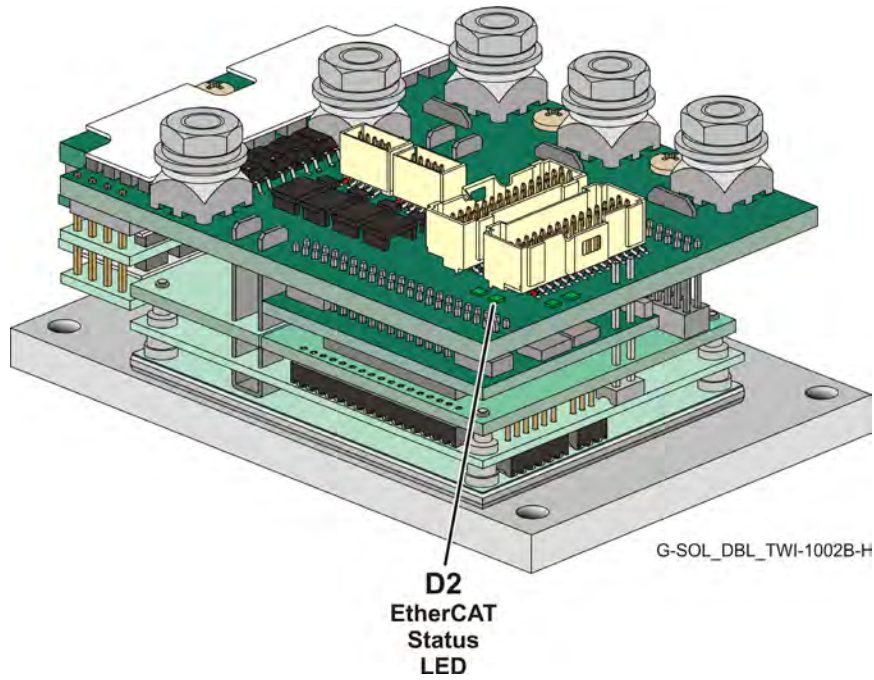

Figure 38: EtherCAT Status LED

The EtherCAT status indicator D2 is a single red/green dual bi-colored LED that combines the green RUN indicator and the red ERROR indicator of the EtherCAT state machine. For further details, see the EtherCAT Application Manual.



8.5.3.3. EtherCAT Link Indicators (D3, D4)

The Gold Solo Twitter B can serve as an EtherCAT slave device. For this purpose it has two Ports J17 and J18, which are designated as EtherCAT In and EtherCAT Out. Each of these Ports has a status LED; D3 EtherCAT In and D4 EtherCAT Out, which are shown in Figure 39.

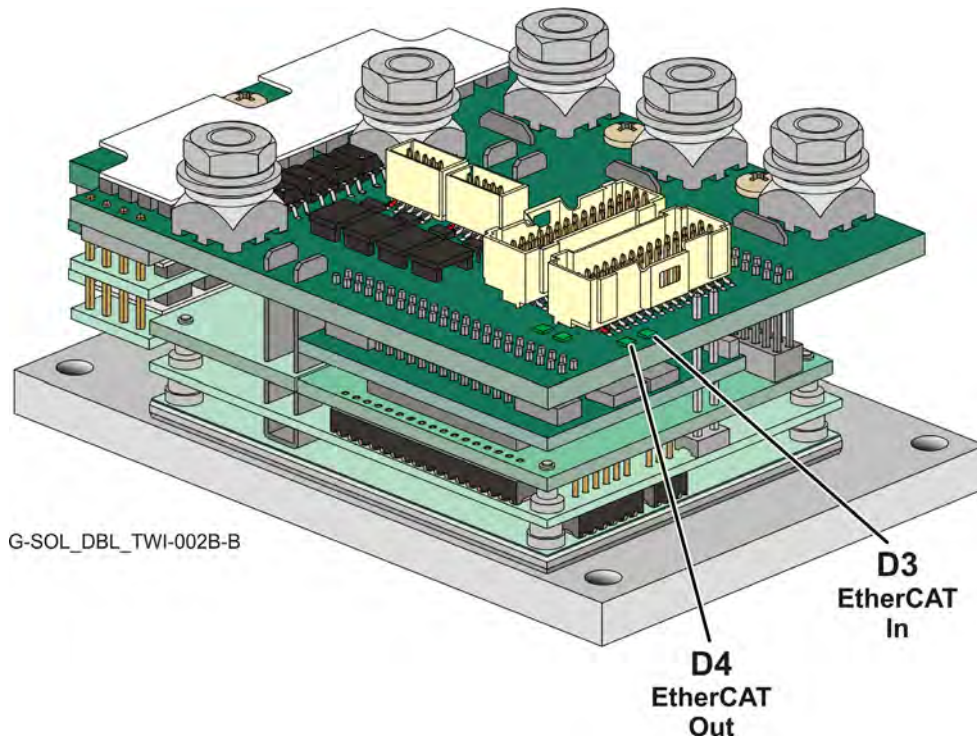

Figure 39: Ethernet Connector LEDs

The green LEDs D3 and D4 are the link/activity indicators. They show the state of the applicable physical link and the activity on that link; blinking green, D3 for the Link Act IN, and D4 for the Link Act OUT.



8.6. CAN Communications Version

Fieldbus communications are industrial network protocols for real-time distributed control that allows connection of servo drives. The Gold Solo Twitter B supports the following CAN fieldbus type industrial network protocol:

Fieldbus Type	Product Number
CAN	G-SOLTWIDXXX/YYSESVD

See Section 12.4 in the MAN-G-Panel Mounted Drives Hardware manual for the electrical diagram.

8.6.1. CAN IN Connector (J17)

Pin (J17)	Signal	Function
1	NC	NC
4	CAN_L	CAN_L bus line (dominant low)
3	CAN_H	CAN_H bus line (dominant high)
2	CAN_RET	CAN Return
5	COMRET	Shield drain wire

Pin Positions	Cable Connector
<p style="text-align: center;">J17 Pin Numbers</p> <p style="text-align: center;">1 5</p> <p style="text-align: center;">J17</p> <p>G-SOL_DBL_TWI-005B-C_CAN</p>	<p style="text-align: right;">Pin #5</p> <p style="text-align: center;">Pin #2</p> <p style="text-align: center;">CAN Cable Connector</p>

Table 9: CAN IN Connector Pin Assignments



8.6.2. CAN OUT Connector (J18)

Pin (J18)	Signal	Function
1	NC	NC
4	CAN_L	CAN_L bus line (dominant low)
3	CAN_H	CAN_H bus line (dominant high)
2	CAN_RET	CAN Return
5	COMRET	Shield drain wire

Pin Positions	Cable Connector
<p>G-SOL_DBL_TWI-005B-B_CAN</p>	<p>CAN Cable Connector</p>

Table 10: CAN OUT Connectors Pin Assignments



8.6.3. CAN Option

For full details on CANopen communication, see section 14.3 in the MAN-G-Board Level Modules Hardware manual.

8.6.3.1. Interface

The Gold Solo Twitter includes the CAN transceiver, common mode choke, and a CAN Bus Protector against ESD and other harmful transient voltage events.

The following signals describe how to connect CAN to the external connector.

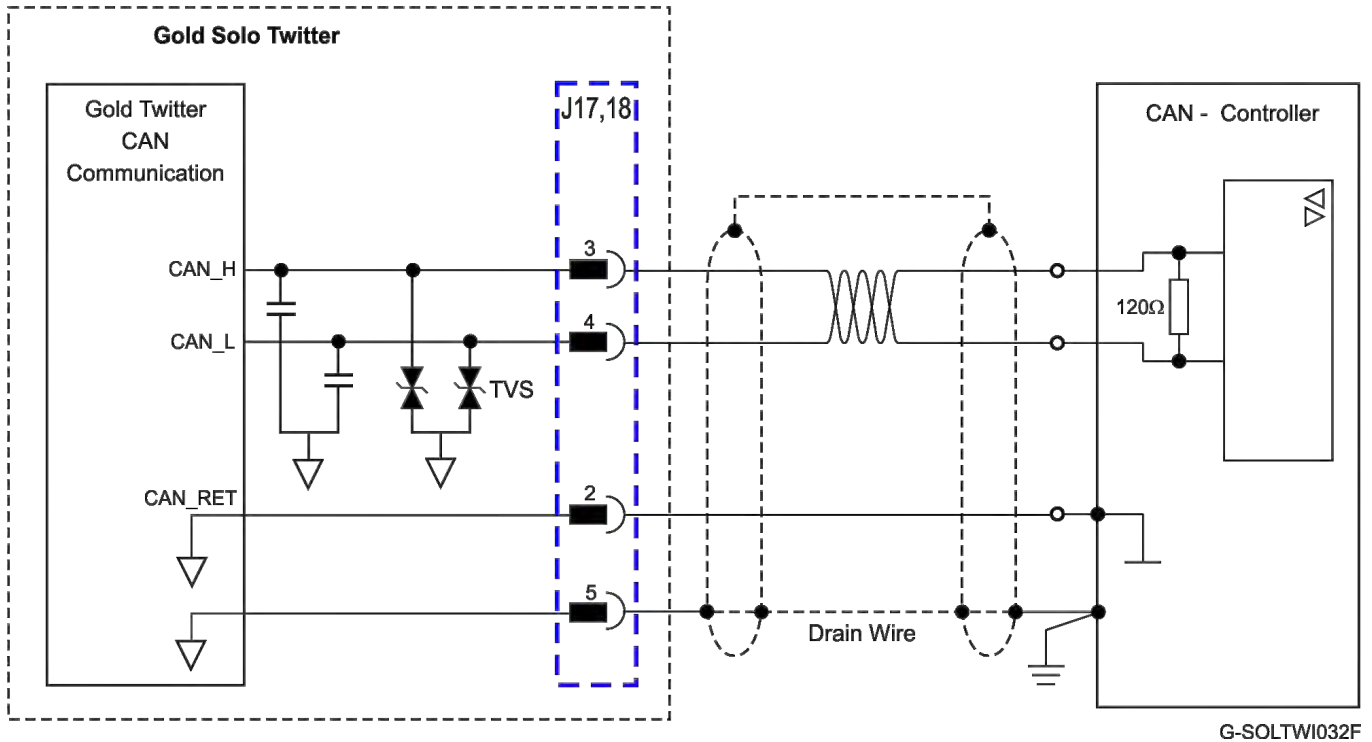
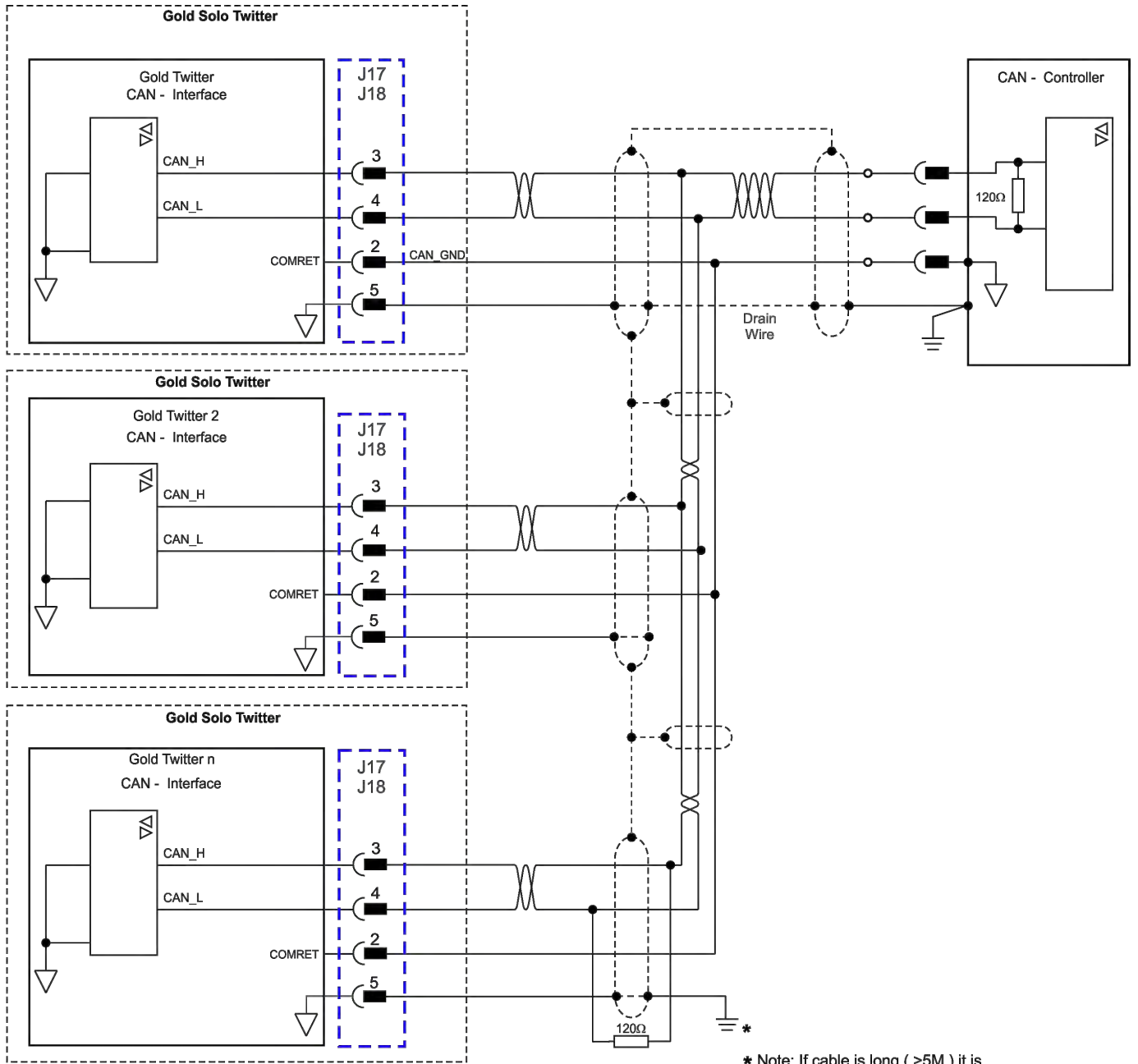

Figure 40: CAN Interface



8.6.3.2. CAN Layout



* Note: If cable is long (>5M) it is recommended to ground at both ends

G-SOLTWI026D

Figure 41: CAN Network Diagram – Drop Off Topology



Caution: When installing CAN communication, ensure that each servo drive is allocated a unique ID. Otherwise, the CAN network may “hang”.

Note: Daisy chain topology can also be accomplished using J18.



Chapter 9: Powering Up

After the Gold Solo Twitter B is connected to its device, it is ready to be powered up.



Caution:

Before applying power, ensure that the DC supply is within the specified range and that the proper plus-minus connections are in order.

9.1. Initializing the System

After the Gold Solo Twitter B has been connected and mounted, the system must be set up and initialized. This is accomplished using the *EASII*, Elmo's Windows-based software application. Install the application and then perform setup and initialization according to the directions in the *EASII User Manual*.



9.2. Heat Dissipation

The best way to dissipate heat from the Gold Solo Twitter B is to mount it so that its heat-sink is attached to the machine chassis. If mounted with its heat-sink suspended, then for best results mount the servo drive faced upwards and leave approximately 10 mm of space between the Gold Solo Twitter B's heat-sink and any other assembly.

9.2.1. Heat Dissipation Data

Heat Dissipation is shown graphically below. The graphs below describe the basic drive (G-SOLTWIDXXX/YYYYESVD). It should also be noted that the Heat Sink of the model G-SOLTWIDXXX/YYYYESVH can dissipate up to 7.5 W.

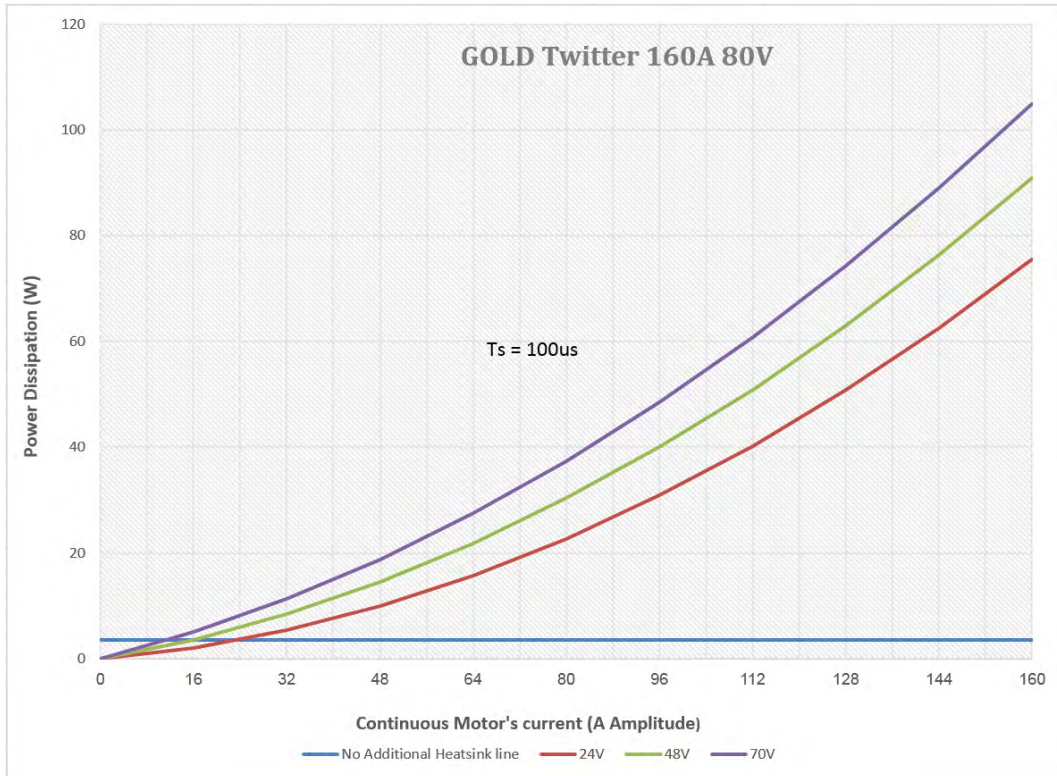

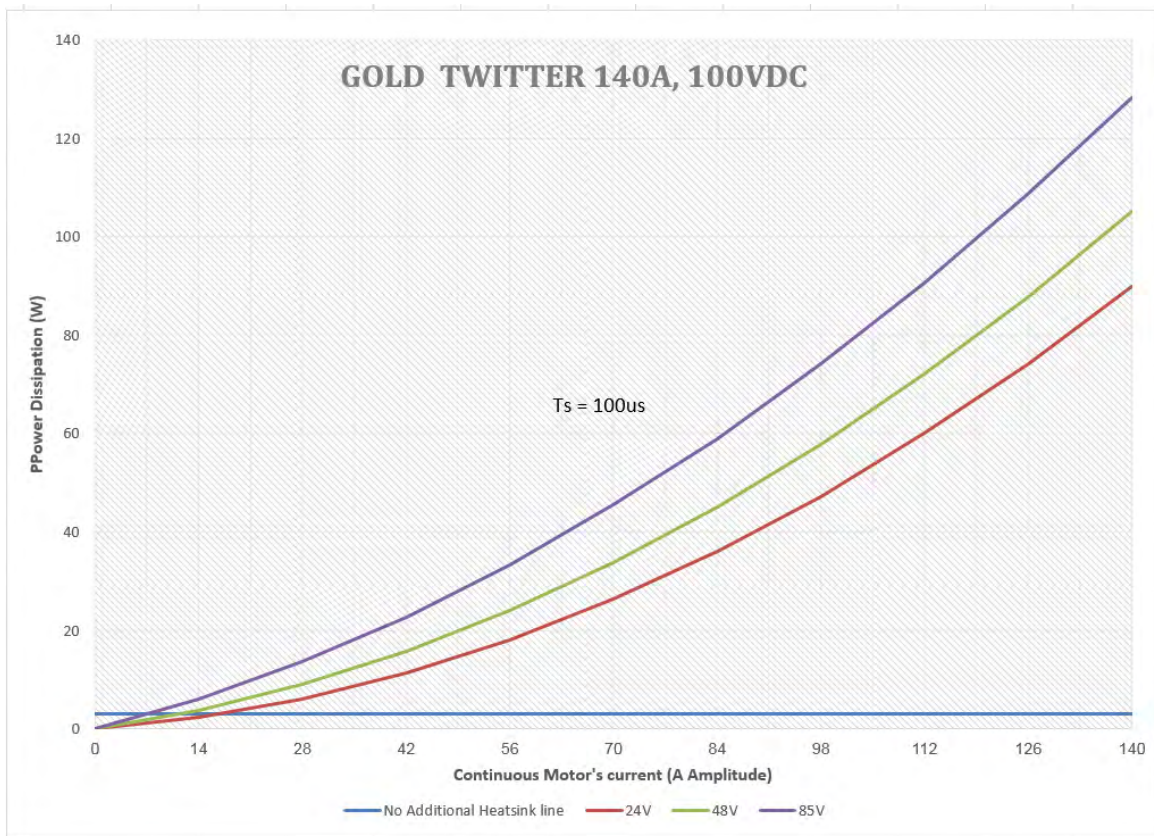
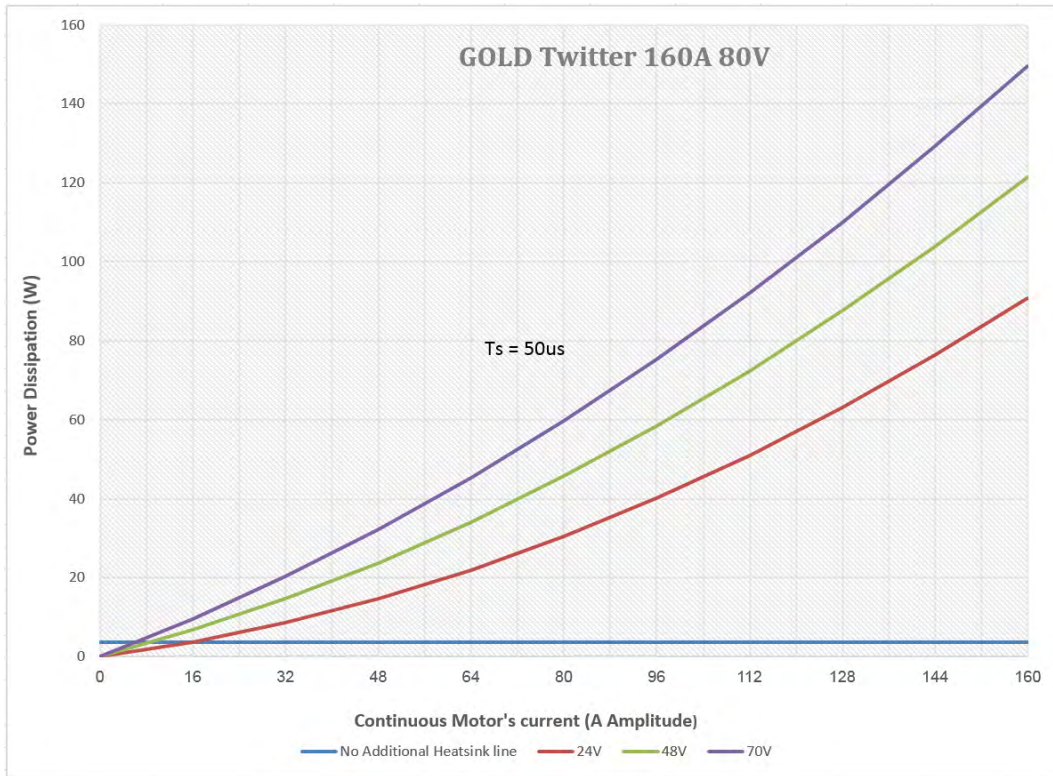

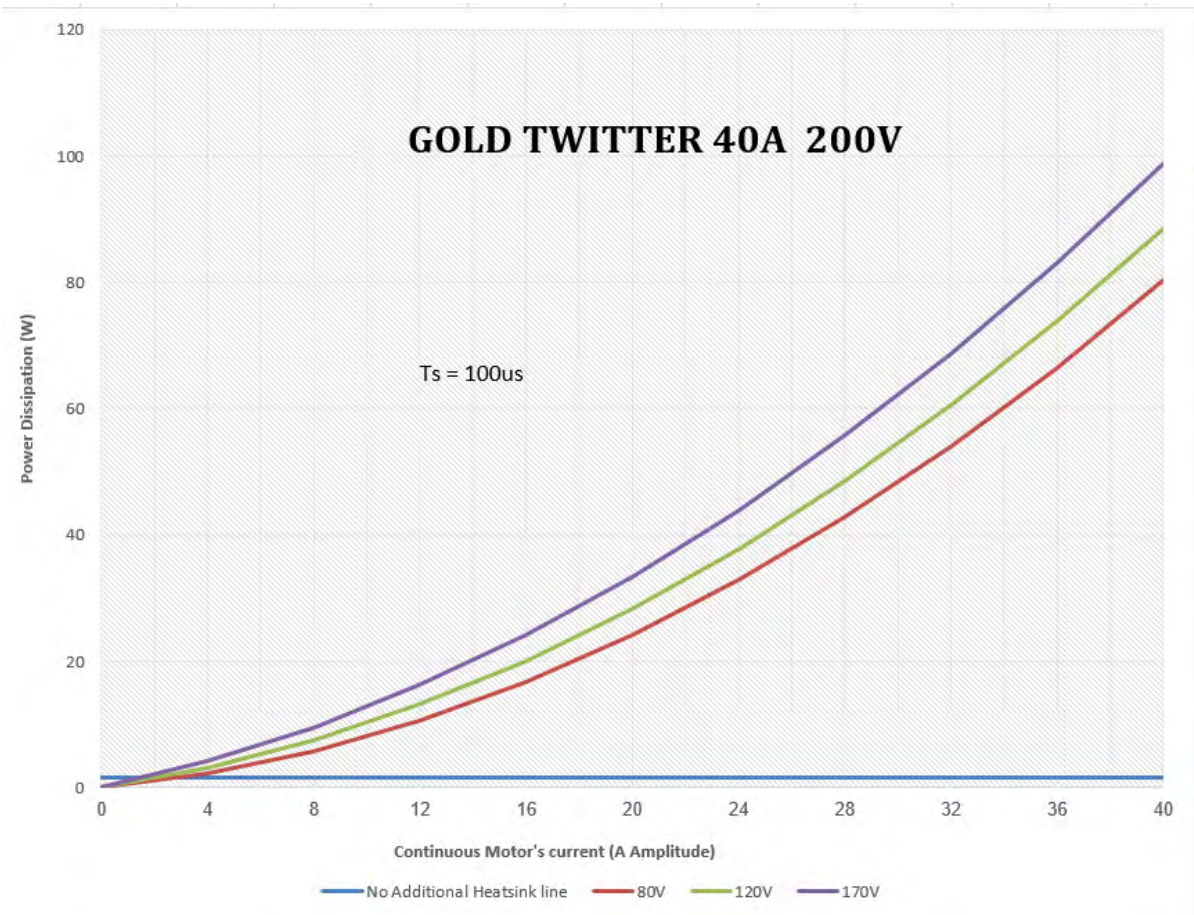
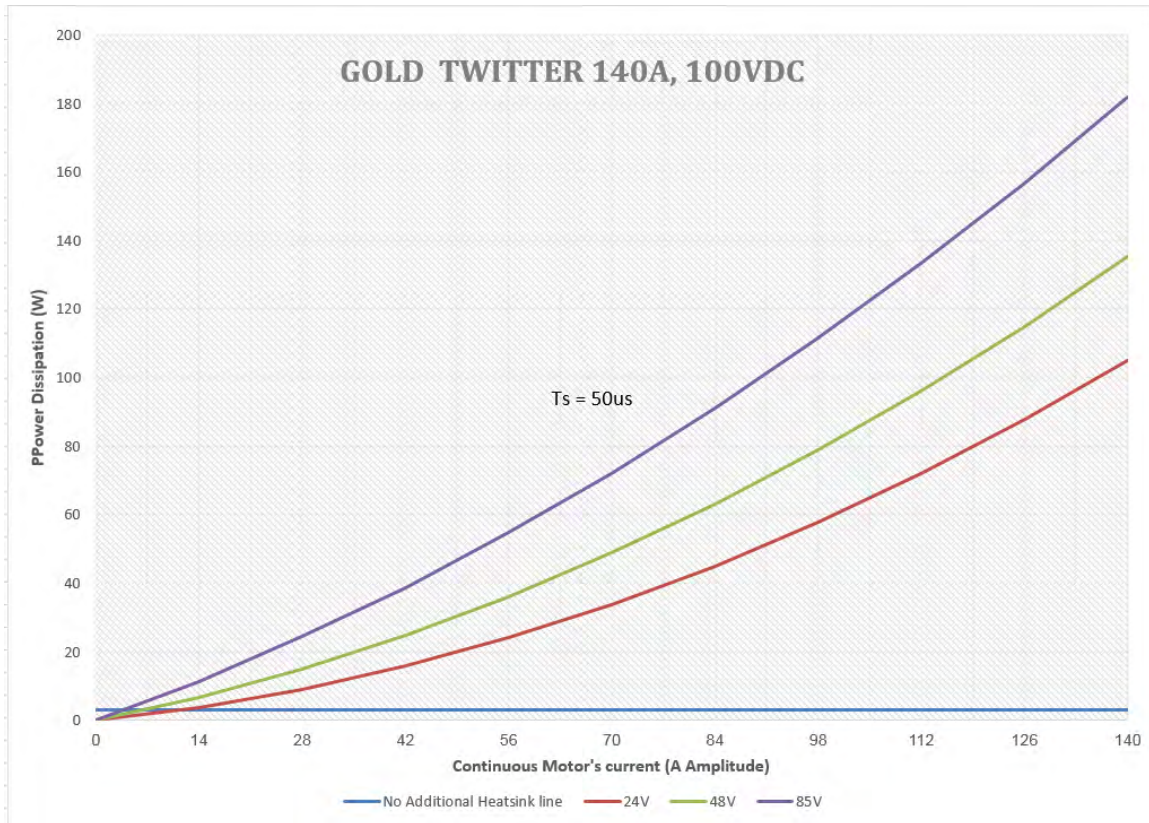

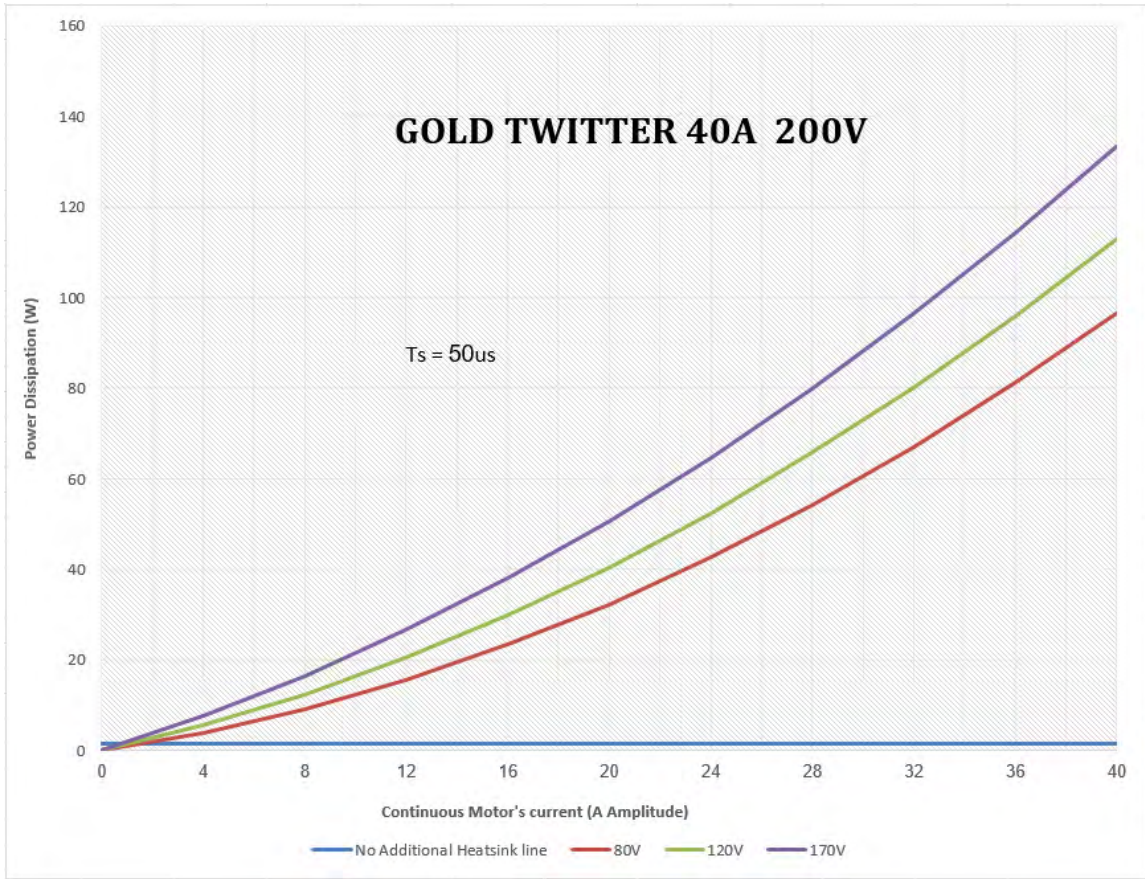



9.2.2. How to Use the Chart

The charts above are based upon the theoretical worst-case scenario. The actual test results display a 20% -30% lower power dissipation.

The above charts indicate the net power conversion losses and exclude the control losses.

To determine if your application heat dissipation requires a heat sink:

1. Determine the power dissipation according to the "continuous current" and the DC bus voltage curve.
If the DC bus is not one of the three curves above, estimate the dissipation by interpolation. The estimation error is not critical.
2. The chart is calculated for continuous current operation, if the actual operation is pulsed current, add 25% to 30% to the power dissipation of the average (RMS) current.
3. When the Heat-Sink temperature reaches $\approx 85^{\circ}\text{C}$, the Gold Solo Twitter B will shut down. Design the system for continuous operation so that the maximum Heat Sink temperature should be no higher than between 80°C to 82°C .
4. If the average heat dissipation capability of the Heat-sink is less than $\approx 3\text{W}$ to 4W (Average operating power of 300W to 500W) there will be no requirement for an additional external heat sink.
5. If the average Heat dissipation is higher than 3W then an additional heat dissipation means is required, usually by connecting to an external heat-sink.
6. When an external Heat-Sink is required, calculate the thermal resistance of the heat sink according to:

$$\Phi_{\text{C/W}} = \frac{80^{\circ}\text{C} - T_{\text{Ambient}}}{\text{Heat Dissipation}}$$



Chapter 10: Dimensions

This chapter provides detailed technical dimensions regarding the Gold Solo Twitter B.

10.1. Dimensions including Base Heat Sink

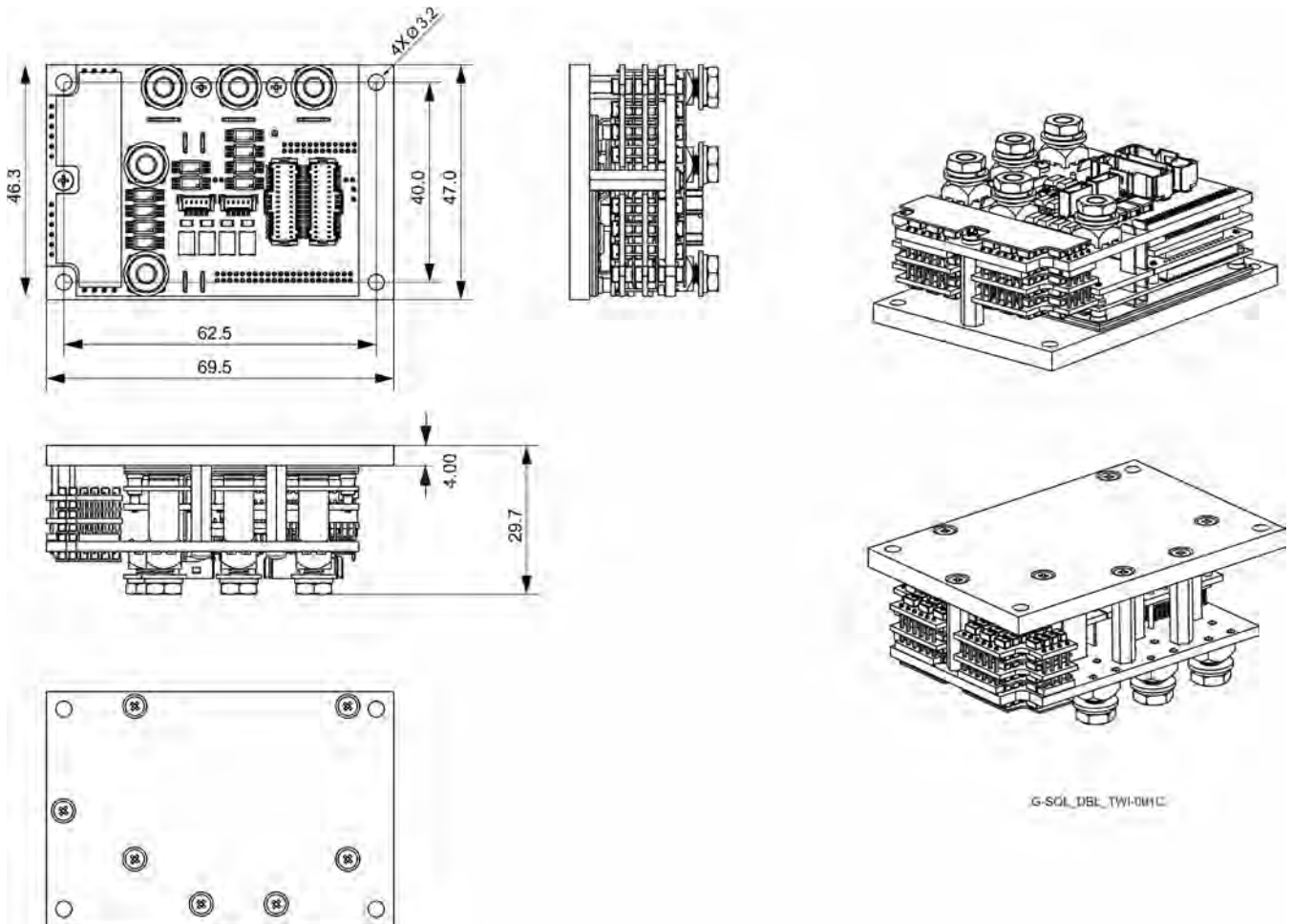

Figure 42: G-Solo Twitter –EtherCAT version

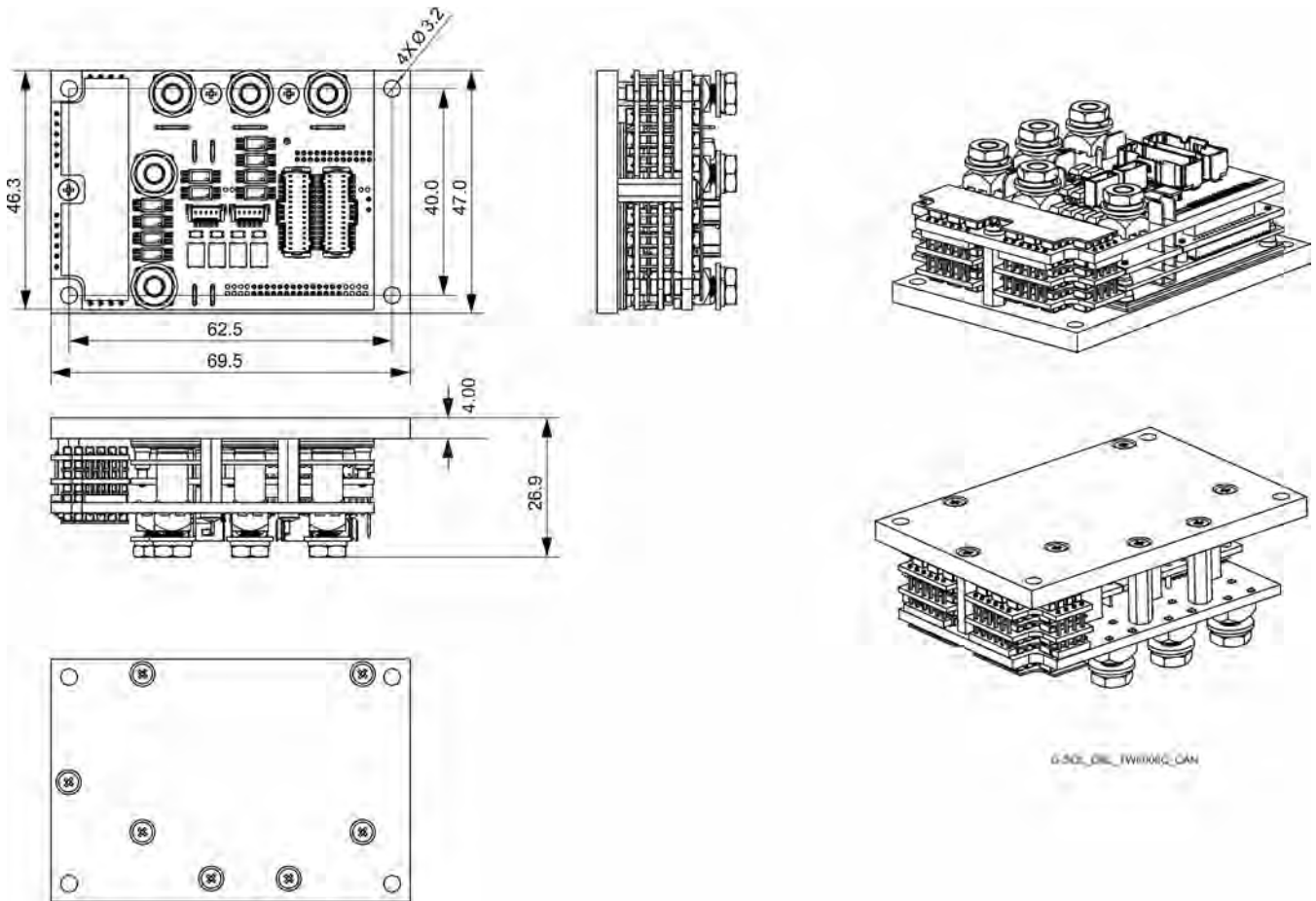

Figure 43: G-Solo Twitter –CAN version



10.2. Dimensions without Base Heat Sink

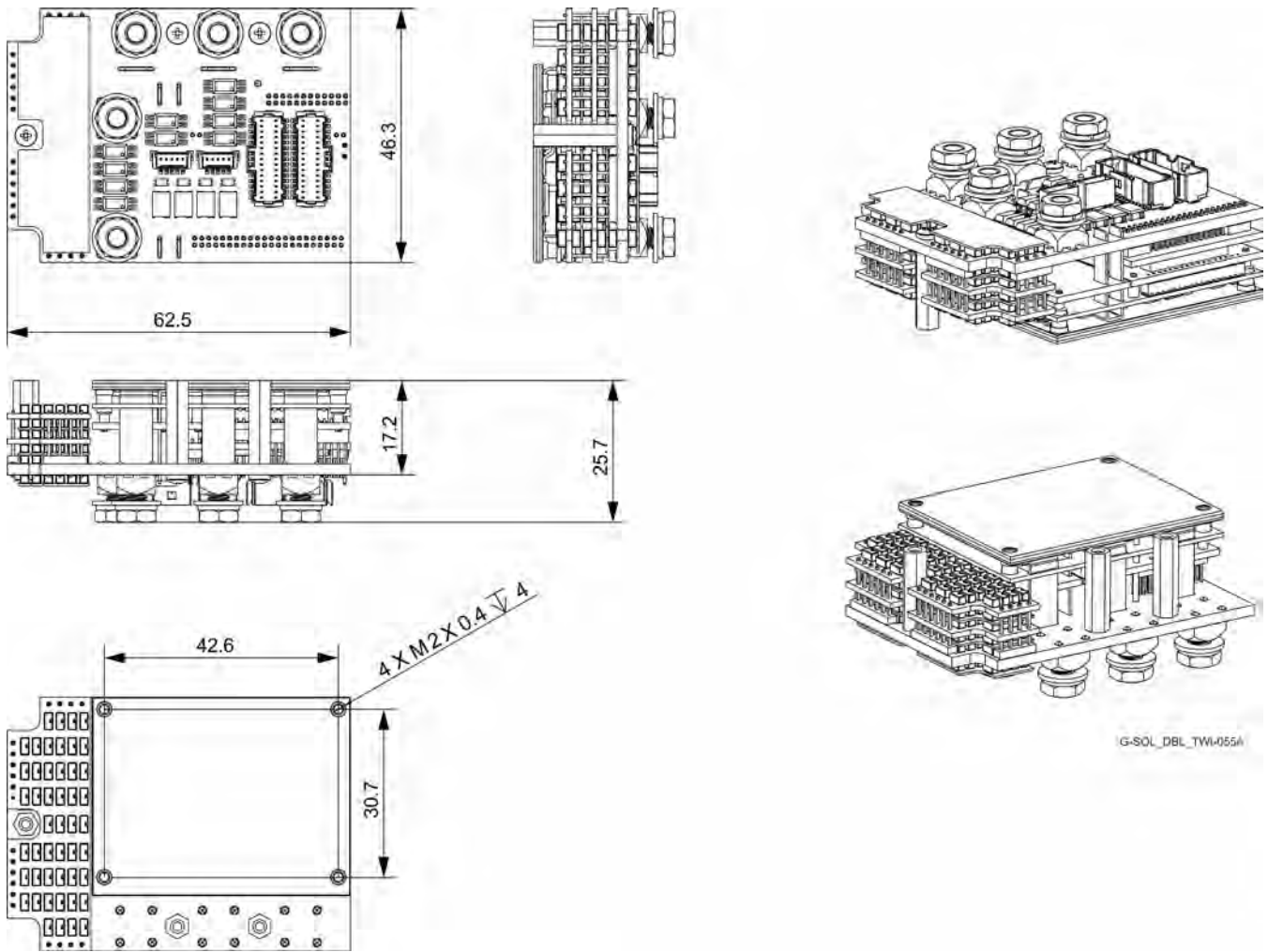

Figure 44: G-Solo Twitter –EtherCAT version

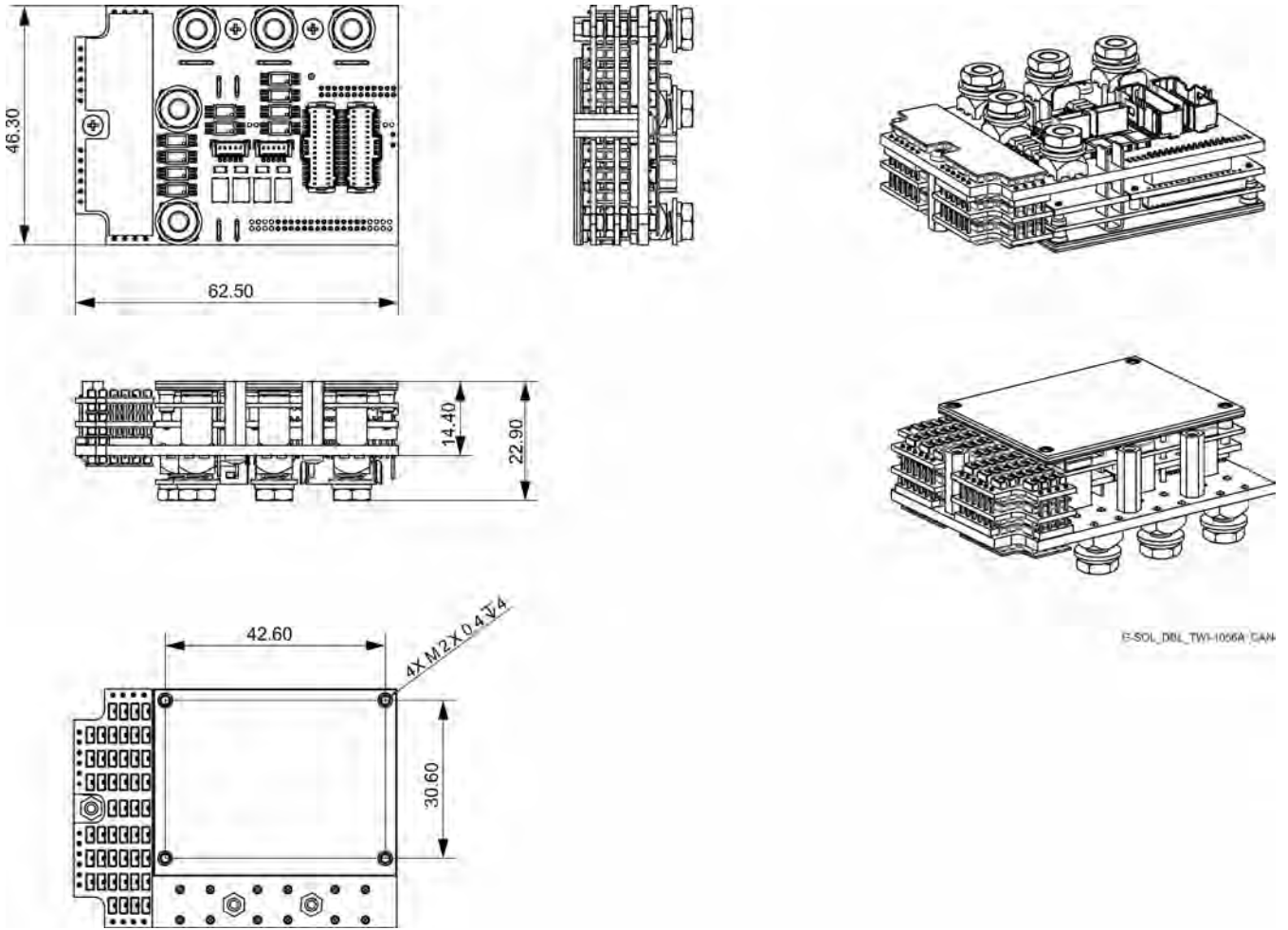

Figure 45: G-Solo Twitter –CAN version



Chapter 11: Accessories

The following describes the accessory kits available for the Gold Solo Twitter B.

Part Number	Description
CBL-GSOLTWIKIT03	Kit cable for EtherCAT model
CBL-GSOLTWIKIT04	Kit cable for CAN model
CBL-GSOLTWIKIT05	CONNECTORS AND PINS KIT

A specific Crimping Tool (available for purchase from Elmo) is required to mount extra connecting pins on the wires. A number of wires are provided in the kit as pre-crimped for convenience:



Crimping Tool
Molex P/N 63819-1500
Elmo P/N TOOL-P000040



Pins for Single Row Connector
MOLEX P/N 501334-0100
Pins for Dual Row Connector
MOLEX P/N 501193-3000

Inspiring Motion

Since 1988

For a list of Elmo's branches, and your local area office, refer to the Elmo site www.elmomc.com

