

Gold Eagle
550A / 100VDC
650A / 80VDC
Digital Servo Drive
Installation Guide



Notice

This guide is delivered subject to the following conditions and restrictions:

- This guide contains proprietary information belonging to Elmo Motion Control Ltd. Such information is supplied solely for the purpose of assisting users of the Gold Eagle 550/650 servo drive in its installation.
- The text and graphics included in this manual are for the purpose of illustration and reference only. The specifications on which they are based are subject to change without notice.
- Information in this document is subject to change without notice.

Document no. MAN-G-EAG550IG-EC (Ver. 1.007)

Copyright © 2017

Elmo Motion Control Ltd.

All rights reserved.

Catalog Number

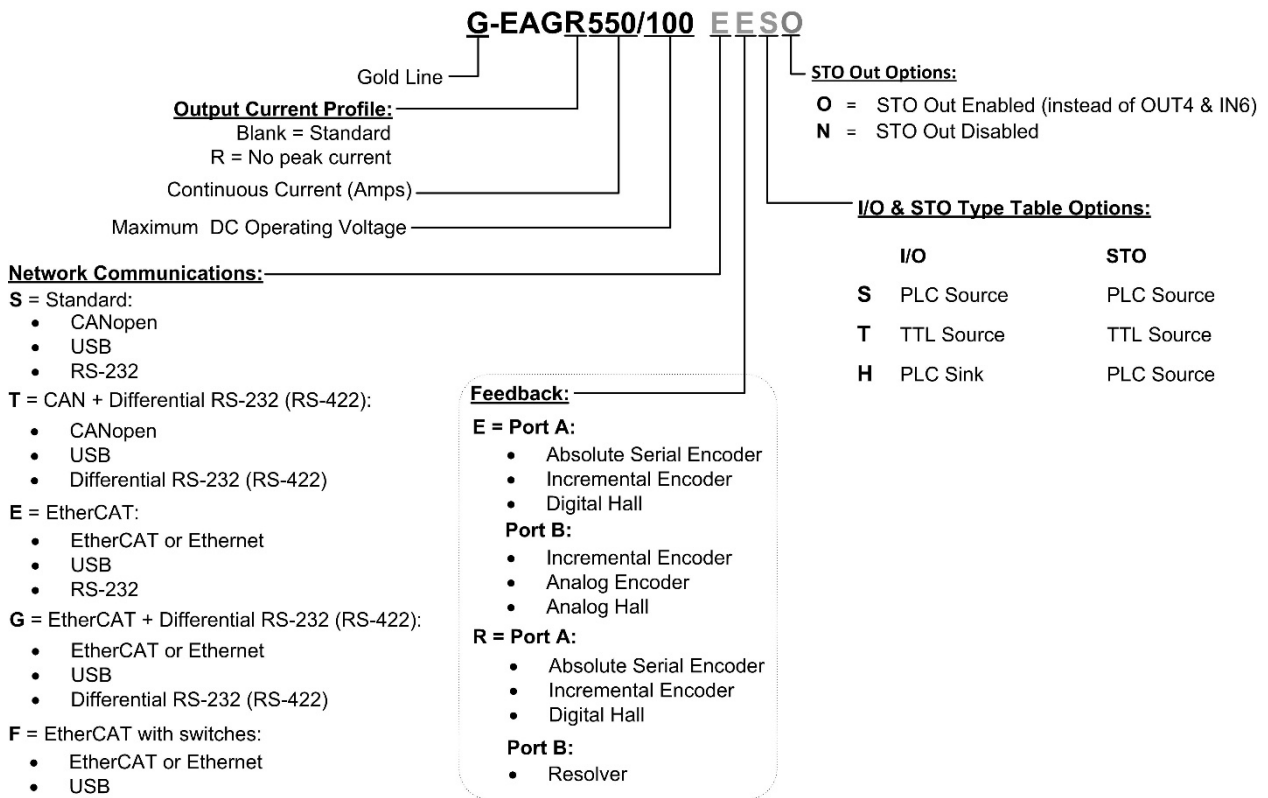

Revision History

Version	Date
Ver. 1.000	Jan 2016
Ver. 1.001	Feb 2016
Ver. 1.002	Jul 2016
Ver. 1.003	Mar 2017
Ver. 1.004	Mar 2017
Ver. 1.005	Jun 2017
Ver. 1.006	Aug 2017
Ver. 1.007	Aug 2017

1.	This Installation Guide	6
2.	Safety Information	6
2.1	Warnings	7
2.2	Cautions.....	7
2.3	CE Marking Conformance.....	7
2.4	Warranty Information	7
3.	Product Description	8
4.	Technical Information.....	9
4.1	Physical Specifications.....	9
4.2	Technical Data	9
4.2.1	Control Backup Supply	10
4.2.2	Product Features	10
4.2.3	Environmental Conditions.....	11
4.2.4	Gold Line Standards.....	12
4.2.5	Environmental	12
4.2.6	EMC	12
4.2.7	EtherCAT Conformance	12
4.2.8	Other Compliant Standards.....	13
5.	Installation	14
5.1	Unpacking the Drive Components	14
5.2	Connectors Types	15
5.2.1	Recommended Cable Lugs and Cabling	17
5.3	Mounting the Gold Eagle 550/650.....	18
5.4	Connection Diagrams	19
5.4.1	Connection Diagrams for EtherCAT Version	19
5.4.2	Connection Diagrams for CAN Version.....	20
6.	Wiring	21
6.1	Basic Recommendations	23
6.1.1	General	23
6.1.2	Feedback Cable Port A and Port B Connector	24
6.1.3	Feedback Cable Port C Connector	25
6.1.4	IO Cable Connector	25
6.1.5	STO (Port C) Cable Connector.....	26
6.2	Main Power and Control Supply	27
6.2.1	Main Power with Control Backup(VCB) Topology.....	28
6.2.2	DC Power	29
6.2.3	Control Backup Supply(VCB)	30
6.3	Motor Power Connector Pinouts	32
6.4	Connecting the DC Power and the Motor Power Cables	34

6.4.1	Motor Power	35
6.5	Port A.....	36
6.5.1	Incremental Encoder	37
6.5.2	Hall Sensor.....	37
6.5.3	Absolute Serial Type Encoder.....	38
6.6	Port B Connector.....	40
6.6.1	Incremental Encoder	41
6.6.2	Interpolated Analog Encoder	42
6.6.3	Resolver	43
6.7	Port C, Analog Input, and STO.....	44
6.7.1	Port C.....	46
6.7.2	Analog Input	46
6.7.3	STO	47
	6.7.3.1 Source Mode PLC Voltage Level	47
	6.7.3.2 TTL Mode TTL Voltage Level.....	47
6.8	Digital Inputs and Outputs	48
6.8.1	Digital Input and Output TTL Source Mode.....	50
6.8.2	Digital Input and Output PLC Source Mode	52
6.8.3	Digital Input and Output PLC Sink Mode.....	54
6.9	USB 2.0 Option 1	56
6.10	VCB/Communication Connector	57
6.10.1	USB 2.0 Option 2	58
6.10.2	RS-232.....	59
6.10.3	RS-422 (Differential RS-232).....	59
6.11	EtherCAT Communications Version	60
6.11.1	EtherCAT/Ethernet Pinouts	60
6.11.2	EtherCAT Wiring	61
6.11.3	EtherCAT and Drive Status Indicator LEDs	62
6.11.4	EtherCAT Rotary Switches	63
6.12	CAN Communications Version	64
6.12.1	CAN Wiring	65
6.12.2	CAN Indicator	66
7.	Heat Dissipation	67
7.1	Gold Eagle 550/650 Thermal Data	67
7.2	Heat Dissipation Data.....	68
7.3	How to Use the Charts	70
7.4	Thermal Operating Envelope	70
8.	Powering Up.....	72
8.1	Initializing the System	72
9.	Gold Eagle 550/650 Dimensions	73



1. This Installation Guide

This installation Guide details the technical data, pinouts, and power connectivity of the Gold Eagle 550/650. For a comprehensive detailed description of the functions, refer to the MAN-G-Panel Mounted Drives Hardware manual, which describes Panel Mounted products.

2. Safety Information

In order to achieve the optimum, safe operation of the Gold Eagle 550/650, it is imperative that you implement the safety procedures included in this installation guide. This information is provided to protect you and to keep your work area safe when operating the Gold Eagle 550/650 and accompanying equipment.

Please read this chapter carefully before you begin the installation process.

Before you start, ensure that all system components are connected to earth ground. Electrical safety is provided through a low-resistance earth connection.

Only qualified personnel may install, adjust, maintain and repair the servo drive. A qualified person has the knowledge and authorization to perform tasks such as transporting, assembling, installing, commissioning and operating motors.

The Gold Eagle 550/650 contains electrostatic-sensitive components that can be damaged if handled incorrectly. To prevent any electrostatic damage, avoid contact with highly insulating materials, such as plastic film and synthetic fabrics. Place the product on a conductive surface and ground yourself in order to discharge any possible static electricity build-up.

To avoid any potential hazards that may cause severe personal injury or damage to the product during operation, keep all covers and cabinet doors shut.

The following safety symbols are used in this and all Elmo Motion Control manuals:



Warning:

This information is needed to avoid a safety hazard, which might cause bodily injury or death as a result of incorrect operation.



Caution:

This information is necessary to prevent bodily injury, damage to the product or to other equipment.



Important:

Identifies information that is critical for successful application and understanding of the product.



2.1 Warnings

- To avoid electric arcing and hazards to personnel and electrical contacts, never connect/disconnect the servo drive while the power source is on.
- Power cables can carry a high voltage, even when the motor is not in motion. Disconnect the Gold Eagle 550/650 from all voltage sources before servicing.
- The high voltage products within the Gold Line range contain grounding conduits for electric current protection. Any disruption to these conduits may cause the instrument to become hot (live) and dangerous.
- After shutting off the power and removing the power source from your equipment, wait at least 1 minute before touching or disconnecting parts of the equipment that are normally loaded with electrical charges (such as capacitors or contacts). Measuring the electrical contact points with a meter, before touching the equipment, is recommended.



2.2 Cautions

- The maximum DC power supply connected to the instrument must comply with the parameters outlined in this guide.
- When connecting the Gold Eagle 550/650 to an approved isolated control backup (VCB), route the cables separately from other power cables, in accordance with approved safety standards.
- Before switching on the Gold Eagle 550/650, verify that all safety precautions have been observed and that the installation procedures in this manual have been followed.
- Make sure that the Safe Torque Off is operational

2.3 CE Marking Conformance

The Gold Eagle 550/650 is intended for incorporation in a machine or end product. The actual end product must comply with all safety aspects of the relevant requirements of the European Safety of Machinery Directive 2006/42/EC as amended, and with those of the most recent versions of standards EN 60204-1 and EN ISO 12100 at the least, and in accordance with 2006/95/EC.

Concerning electrical equipment designed for use within certain voltage limits, the Gold Eagle 550/650 meets the provisions outlined in 2006/95/EC. The party responsible for ensuring that the equipment meets the limits required by EMC regulations is the manufacturer of the end product.

2.4 Warranty Information

The products covered in this manual are warranted to be free of defects in material and workmanship and conform to the specifications stated either within this document or in the product catalog description. All Elmo drives are warranted for a period of 12 months from the date of shipment. No other warranties, expressed or implied — and including a warranty of merchantability and fitness for a particular purpose — extend beyond this warranty.



3. Product Description

The Gold Eagle 550/650 is a series of super compact digital servo drives, highly resilient and operate from a DC Power Voltage Input source. They are designed to deliver the highest density of power and intelligence. The Gold Eagle 550/100V delivers up to **550 A while operating from a DC bus of 11VDC- 95VDC**, while the Gold Eagle 650/80V delivers up to **650A while operating from a power voltage bus of 11VDC- 75VDC**. **Both drives naturally withstand the surges (40V & 100V) and spikes (250V) that might occur in battery operated systems.**

The digital drives are part of Elmo's advanced Gold Line. They operate from a DC power source in current, velocity, position and advanced position modes, in conjunction with a permanent-magnet synchronous brushless motor, DC brush motor, linear motor or voice coil. They are designed for use with any type of sinusoidal and trapezoidal commutation, with vector control. The Gold Eagle 550/650 can operate as a stand-alone device or as part of a multi-axis system in a distributed configuration on a real-time network.

The drives are easily set up and tuned using Elmo Application Studio (EASII) software tools. This Windows-based application enables users to quickly and simply configure the servo drive for optimal use with their motor. The Gold Eagle 550/650, as part of the Gold Line, is fully programmable with Elmo's motion control language.

The Gold Eagle 550/650 can operate with the main power supply only (VP+ and PR). Then the control voltage is created by an internal SMPS powered directly from the VP+ supply. If it is required to leave the control section under power, while the power supply (VP+ - PR) is removed, a control backup supply (VCB) with a range of 11 to 95 V can be connected, providing maximum flexibility and optional backup functionality when needed.



4. Technical Information

4.1 Physical Specifications

Feature	Units	All Types
Weight	g (oz)	3.6 Kg (127 oz)
Dimension	mm (in)	195 x 222 x 100 (7.68" x 8.74" x 3.94")
Mounting method		Panel / Wall Mounted

4.2 Technical Data

Feature	Units	R550/100	R650/80
Minimum supply voltage	VDC	11	
Nominal supply voltage	VDC	85	68
Maximum supply voltage	VDC	94	75
Maximum continuous power output(at 85VDC)	kW	25	
Efficiency at rated power (at 500A @ 85VDC)	%	> 99	
VCB supply voltage option	VDC	11 to 95	
VCB power supply	VA	7	
Continuous current limit (Ic) Amplitude sinusoidal/DC trapezoidal commutation	A	550	650
Continuous RMS sinusoidal commutation current limit (Ic)	A	390	460
Peak Current	A	No Peak	



4.2.1 Control Backup Supply

Feature	Details
VCB supply	Isolated from the mains DC source only
VCB supply input voltage	11 VDC to 95 VDC
VCB supply input power	7 VA

4.2.2 Product Features

Main Feature	Details	Presence / No.
STO	TTL, <i>or</i>	√
	PLC Source, <i>or</i>	√
	STO Output Status (instead of OUT4 & IN6)	√
Digital Input Option	TTL Source <i>or</i>	6
	PLC Source <i>or</i>	6
	PLC Sink	6
Digital Output Option	TTL Source <i>or</i>	4
	PLC Source <i>or</i>	4
	PLC Sink	4
Analog Input	Differential ±10 V analog input	1
Feedback	Standard Port A, B, and C	√
Communication Option	USB	√
	EtherCAT without switches <i>or</i>	√
	CAN <i>or</i>	√
	EtherCAT with switches	√
	RS-232 <i>or</i>	√
	RS-422	√



4.2.3 Environmental Conditions

You can guarantee the safe operation of the Gold Eagle 550/650 by ensuring that it is installed in an appropriate environment.



Caution:

The Gold Eagle 550/650 dissipates its heat by convection. The maximum ambient operating temperature of 70 °C (160 °F) must not be exceeded.

The ExtrlQ series of drives support the following extended environmental conditions.

Feature	Operation Conditions	Range
Ambient Temperature Range	Non-operating conditions	-50 °C to +100 °C (-58 °F to 212 °F)
	Operating conditions	-40 °C to +70 °C (-40 °F to 160 °F)
Temperature Shock	Non-operating conditions	-40 °C to +70 °C (-40 °F to 160 °F) within 3 min
Altitude	Non-operating conditions	Unlimited
	Operating conditions	-400 m to 12,000 m (-1312 to 39370 feet)
Maximum Humidity	Non-operating conditions	Up to 95% relative humidity non-condensing at 35 °C (95 °F)
	Operating conditions	Up to 95% relative humidity non-condensing at 25 °C (77 °F), up to 90% relative humidity non-condensing at 42 °C (108 °F)
Vibration	Operating conditions	20 Hz to 2,000 Hz, 14.6 g
Mechanical Shock	Non-operating conditions	±40g; Half sine, 11 msec
	Operating conditions	±20g; Half sine, 11 msec
Atmosphere	Operating area atmosphere	No flammable gases or vapors permitted in area



4.2.4 Gold Line Standards

The following table describes the Main Standards of the Gold Eagle 550/650 servo drive. For further details refer to the MAN-G-Board Level Modules Hardware Manual.

Main Standards	Item
The related standards below apply to the performance of the servo drives as stated in the environmental conditions in section 4.2.3 Environmental Conditions above.	
Conformity with IEC/EN 61800-5-1	Adjustable speed electrical power drive systems Safety requirements – Electrical, thermal and energy
Conformity with UL61800-5-1	Adjustable speed electrical power drive systems Safety requirements – Electrical, thermal and energy
Conformity with CE 2006/95/EC	Low-voltage directive 2006/95/EC
Conformity with CSA C22.2 NO. 14-13	Industrial Control Equipment

4.2.5 Environmental

Specification	Details
Conformity with IEC60068-2-78	Environmental testing – Damp heat, steady state
Conformity with IEC60068-2-6	Environmental testing –Vibration (sinusoidal)
Conformity with IEC60068-2-2	Environmental testing – Dry heat
Conformity with IEC60068-2-27	Basic environmental testing procedures - Shock

4.2.6 EMC

Specification	Details
Conformity with IEC/EN 61800-3	Adjustable speed electrical power drive systems

4.2.7 EtherCAT Conformance

EtherCAT Conformance Test Certified
Approved and certified EtherCAT conformance



4.2.8 Other Compliant Standards

Quality Assurance	
ISO 9001:2008	Quality Management
Design	
<ul style="list-style-type: none"> • IPC-D-275 • IPC-SM-782 • IPC-CM-770 	Printed wiring for electronic equipment (clearance, creepage, spacing, conductors sizing, etc.)
Reliability	
MIL-HDBK- 217F	Reliability prediction of electronic equipment (rating, de-rating, stress, etc.)
Workmanship	
In compliance with IPC-A-610, level 3	Acceptability of electronic assemblies
PCB	
In compliance with IPC-A-600, level 3	Acceptability of printed circuit boards
Packing	
In compliance with EN 100015	Protection of electrostatic sensitive devices
Environment	
In compliance with 2002/96/EC	Waste Electrical and Electronic Equipment regulations (WEEE) Note: Out-of-service Elmo drives should be sent to the nearest Elmo sales office.
In compliance with 2002/95/EC (effective July 2006)	Restrictions on Application of Hazardous Substances in Electric and Electronic Equipment (RoHS)



5. Installation

The Gold Eagle 550/650 must be installed in a suitable environment and properly connected to its voltage supplies and the motor.

5.1 Unpacking the Drive Components

Before you begin working with the Gold Eagle 550/650, verify that you have all of its components, as follows:

- The Gold Eagle 550/650 servo drive
- The Elmo Application Studio (EAS) software and software manual

The Gold Eagle 550/650 is shipped in a cardboard box with Styrofoam protection.

To unpack the Gold Eagle 550/650:

1. Carefully remove the servo drive from the box and the Styrofoam.
2. Check the drive to ensure that there is no visible damage to the instrument. If any damage has occurred, report it immediately to the carrier that delivered your drive.
3. To ensure that the Gold Eagle 550/650 you have unpacked is the appropriate type for your requirements, locate the part number sticker on the side of the Gold Eagle 550/650. It looks like this:



4. Verify that the Gold Eagle 550/650 type is the one that you ordered, and ensure that the voltage meets your specific requirements.

The part number at the top provides the type designation. Refer to the appropriate part number in the section Catalog Number at the beginning of the installation guide.



5.2 Connectors Types

The Gold Eagle 550/650 has the following nine connectors.

Type	Function	Port	Connector Location
Terminal Lug + M10 Flat Washer + M10 Spring Washer + M10 Nut	Power	VP+, PR	<p>The diagram shows a rear terminal block with three motor ports (M1, M2, M3) in the center, flanked by power ports (VP+ on the left, PR on the right) and four earth connection points (PE) at the corners. The ports are color-coded: M1 and M2 are orange, M3 is grey, VP+ and PR are orange, and the PE points are grey.</p>
	Motor	M1, M2, M3	
Terminal Lug + M8 Flat Washer + M8 Spring Washer + M8 screw	Earth Connection	PE, PE, PE, PE	

Recommended for M10 screw **Terminal Lug (FLEX) (Stud hall size: 10 mm (3/8")) 2/0 - 4/0 AWG**

Pins	Type	Function
------	------	----------

Rear Connectors

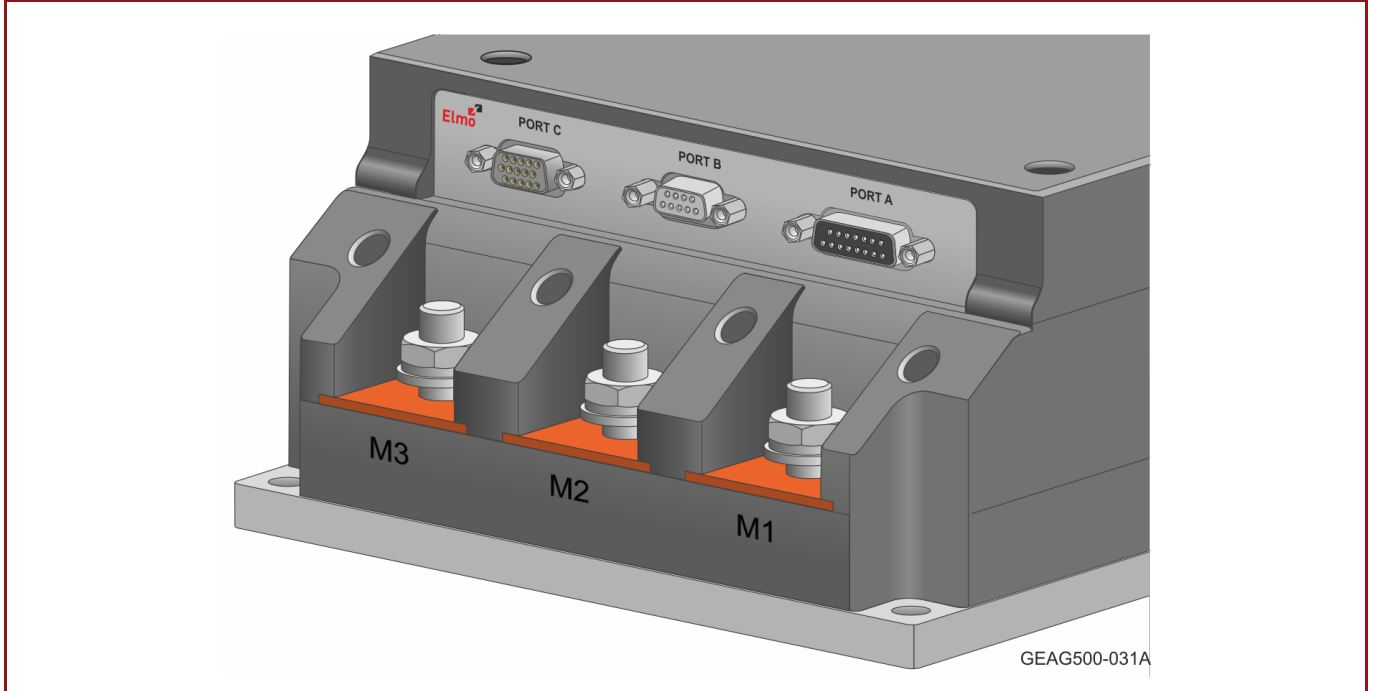

15	Socket D-Type	Port A
9	Socket D-Type	Port B
15	Socket High Density D-Type	Port C and Functional Safety (STO)



Front Connectors

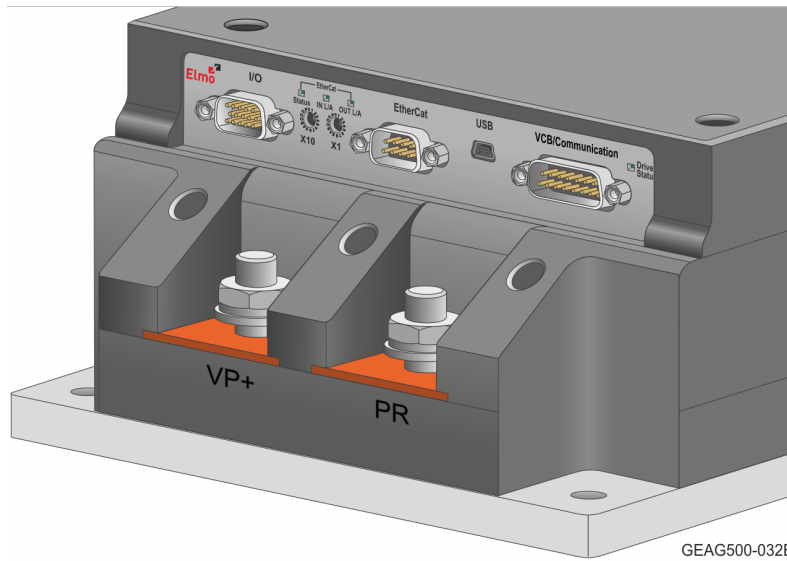

Front Connectors – EtherCAT

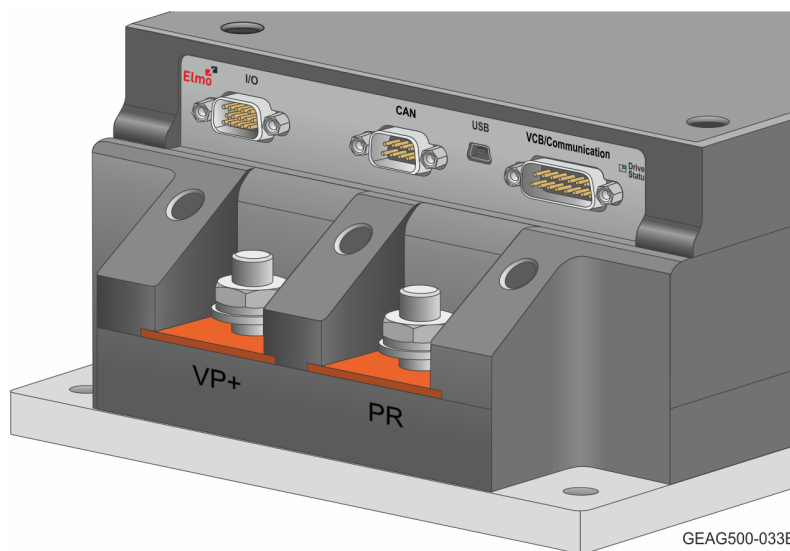

Front Connectors – CAN

Pins	Type	Function
15	Plug High Density D-Type	I/O
15	Plug D-Type	VCB, RS-232, RS-422, USB
EtherCAT Version		
9	Plug D-Type	Ethernet, EtherCAT IN, EtherCAT OUT, communication
4	USB Device Type Mini B	USB communication
CAN Version		
9	Plug D-Type	CAN IN, CAN OUT, communication
4	USB Device Type Mini B	USB communication



5.2.1 Recommended Cable Lugs and Cabling

Elmo recommends the following cable lugs depending on the cable to be installed. Refer to the specification drawings for the UL listed lug and cable application.

Panduit Copper Lug - One-Hole, Standard Flex Barrel

Part No.	Barrel Col. and ID	Wire Size	Wire Type	Wire Strip Length	Stud Size
LCAX1 /0-38-X	Pink P42	1/0 STR/FLEX	Stranded Copper: Class B & C, Compact, Class G, H, I, K, M, Locomotive	3/4 in	3/8 in
LCAX2 /0-38-X	Black P45	2/0 STR/FLEX		7/8 in	3/8 in
LCAX3 /0-38-X	Orange P50	3/0 STR/FLEX		1.0 in	3/8 in
LCAX4 /0-38-X	Purple P54	4/0 STR/FLEX		1-1/16 in	3/8 in



5.3 Mounting the Gold Eagle 550/650

The Gold Eagle 550/650 has been designed for a standard mounting; Wall Mount along the back (can also be mounted horizontally on a metal surface)

Four M8 head cap (Allen) screws with a minimum length of 20 mm, one through each opening in the heat sink, are used to mount the Gold Eagle 550/650 (see the diagram below).

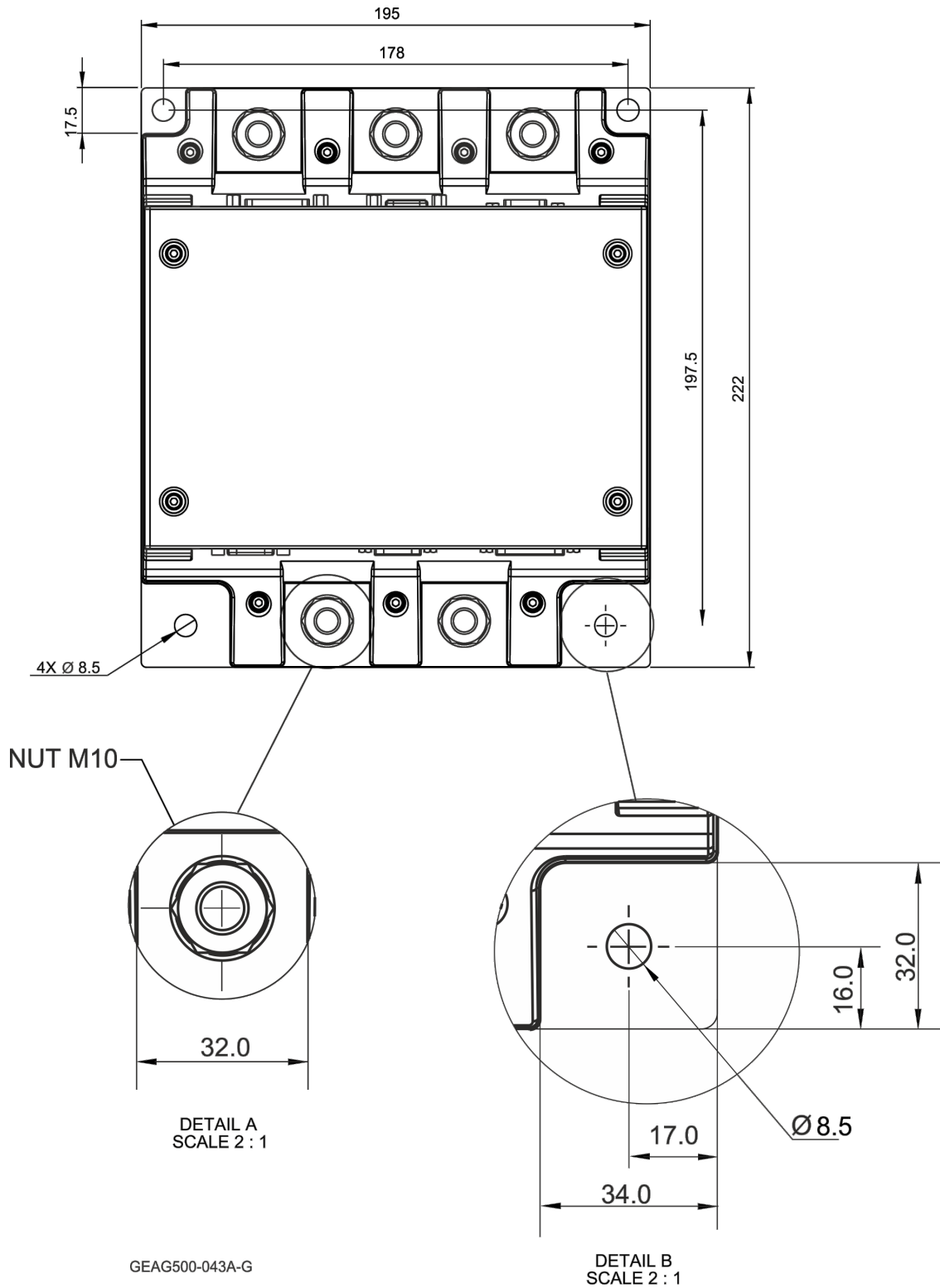

Figure 1: Mounting the Gold Eagle 550/650



5.4 Connection Diagrams

There are connection diagrams for EtherCAT and CAN that show the two different ways of connecting the power supply in the Gold Eagle 550/650 models.

5.4.1 Connection Diagrams for EtherCAT Version

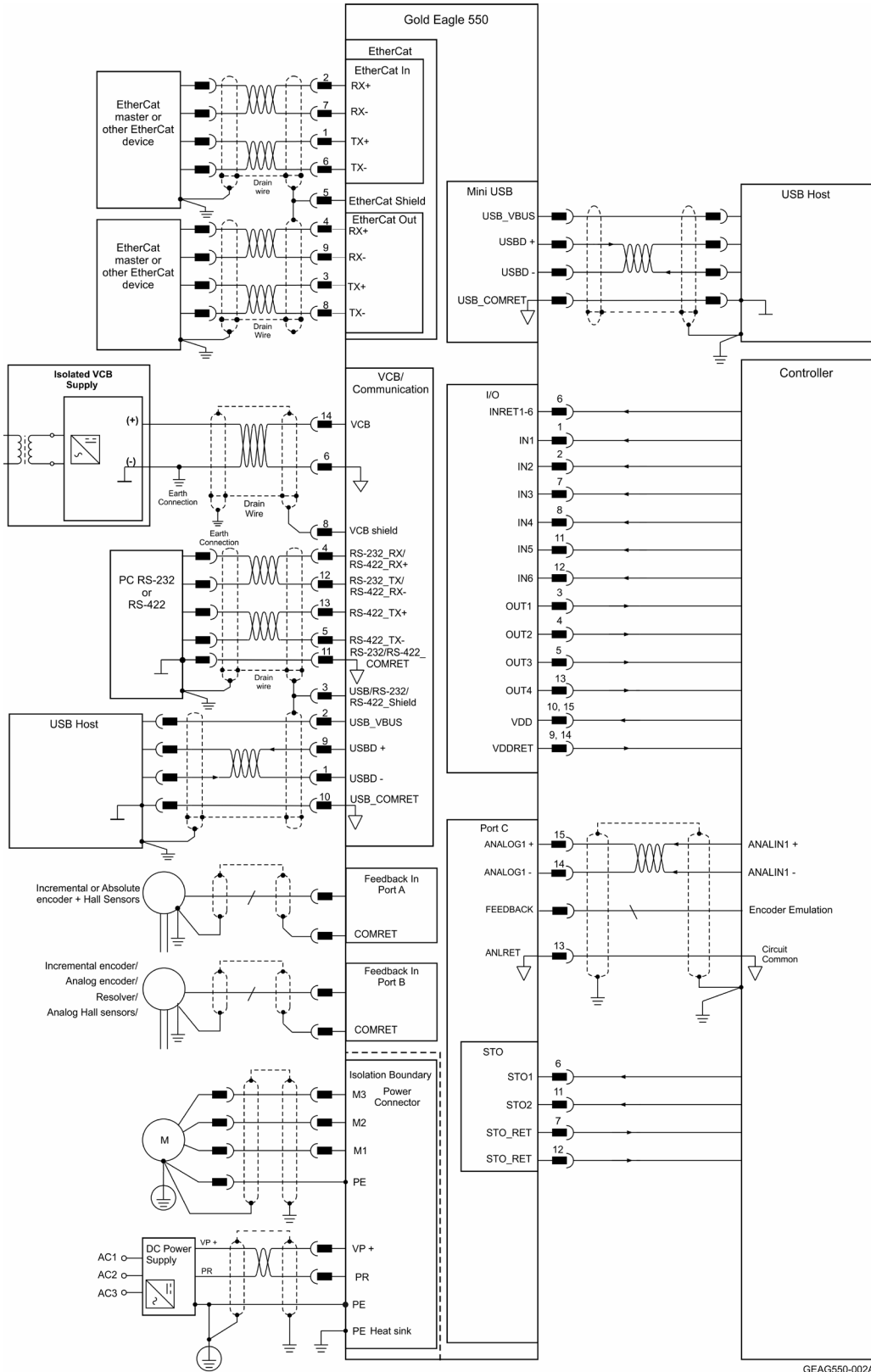

GEAG550-002A

Figure 2: Gold Eagle 550/650 Connection Diagram for EtherCAT



5.4.2 Connection Diagrams for CAN Version

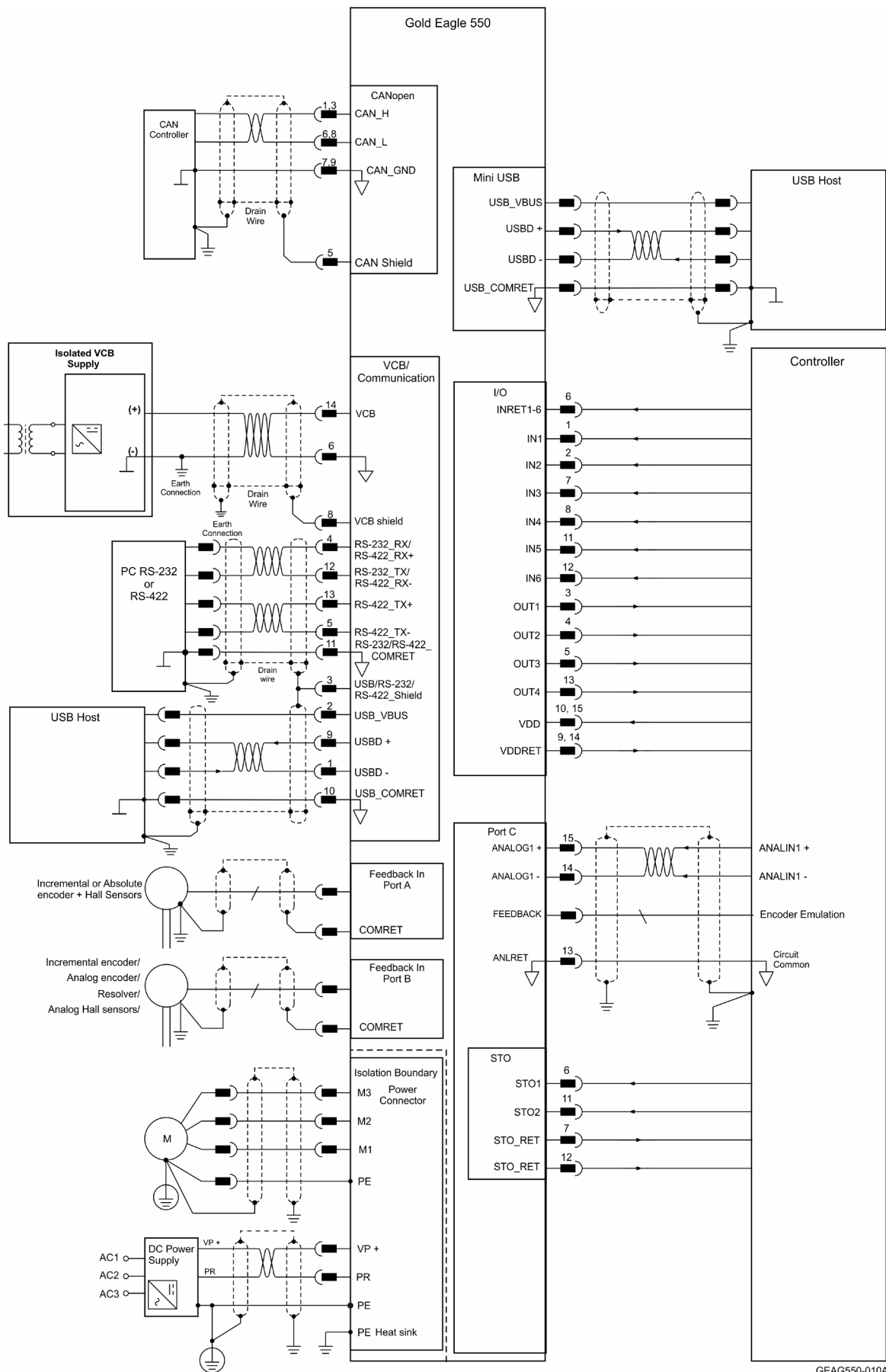

GEAG550-010A

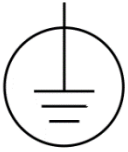

Figure 3: Gold Eagle 550/650 Connection Diagram for CAN



6. Wiring

Once the product is mounted, you are ready to wire the device. Proper wiring, grounding and shielding are essential for ensuring safe, immune and optimal servo performance of the drive.

The following table legend describes the wiring symbols detailed in all installation guides.

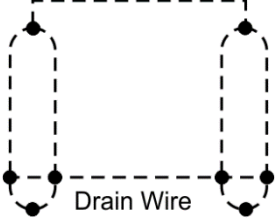
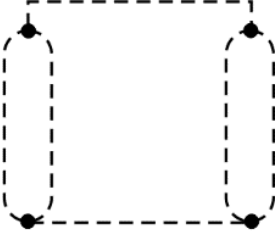
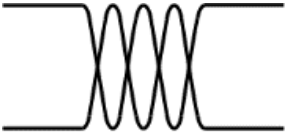
Wiring Symbol	Description
 <p>GGEN_DTTYPE101C-A</p>	Earth connection (PE)
 <p>GGEN_DTTYPE101C-B</p>	Earth Connection
 <p>GGEN_DTTYPE101C-C</p>	Common at the Controller
 <p>Drain Wire</p> <p>GGEN_101D-D</p>	<p>Shielded cable with drain wire.</p> <p>The drain wire is a non-insulated wire that is in direct contact with the braid (shielding).</p> <p>Shielded cable with drain wire significantly simplifies the wiring and earthing.</p>
 <p>GGEN_101D-E</p>	Shielded cable braid only, without drain wire.
 <p>GGEN_101D-F</p>	Twisted-pair wires

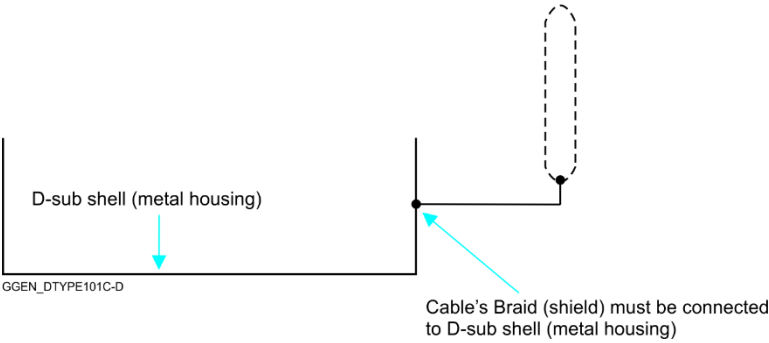
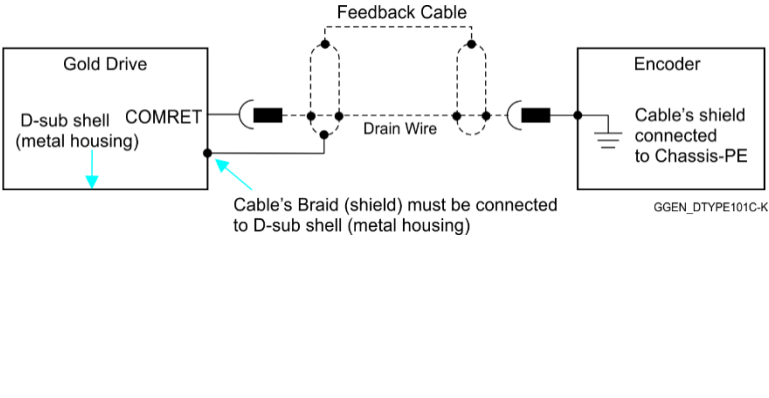

Wiring Symbol	Description
 <p>The diagram shows a D-sub shell (metal housing) on the left. A cable's braid (shield) is shown on the right, connected to the D-sub shell. A blue arrow points from the text 'Cable's Braid (shield) must be connected to D-sub shell (metal housing)' to the connection point. The label 'GGEN_DTYPE101C-D' is at the bottom left.</p>	<p>In the D-type Connector: The cable's braid (Shield) must be connected to the D-sub shell (metal housing)</p>
 <p>The diagram shows a Gold Drive on the left and an Encoder on the right. A Feedback Cable connects them. The Gold Drive's D-sub shell (metal housing) is connected to the COMRET terminal of the Feedback Cable. The Encoder's shield is connected to Chassis-PE. A Drain Wire is also shown. A blue arrow points from the text 'Cable's Braid (shield) must be connected to D-sub shell (metal housing)' to the COMRET connection. The label 'GGEN_DTYPE101C-K' is at the bottom right.</p>	<p>Encoder Earthing. T The cable's shield is connected to the chassis (PE) in the connector. Earthing the Encoder and connecting the Earth (PE) to the drive COMRET is mandatory to insure reliable operation, high noise immunity and rejection of voltage common mode interferences.</p>



6.1 Basic Recommendations

6.1.1 General

1. Use shielded cables. For best results, the cable should have an aluminum foil shield covered by copper braid, and should contain a drain wire.
Use 24, 26 or 28 AWG twisted-pair shielded with drain wire cables.
2. Keep the cable as short as possible.
Do not mount the power cables of the motor and power bus in the proximity of the control and feedback cables.
3. Ensure that in normal operating conditions, the “earth connection” wires and shield of the control cables *carry no current*. The only time these conductors carry current is under abnormal conditions, when electrical equipment has become a potential shock or fire hazard while conducting external EMI interferences directly to ground, in order to prevent them from affecting the drive. Failing to meet this requirement might result in drive/controller/host failure.
4. After completing the wiring, carefully inspect all wires to ensure tightness, good solder of joints and general safety.

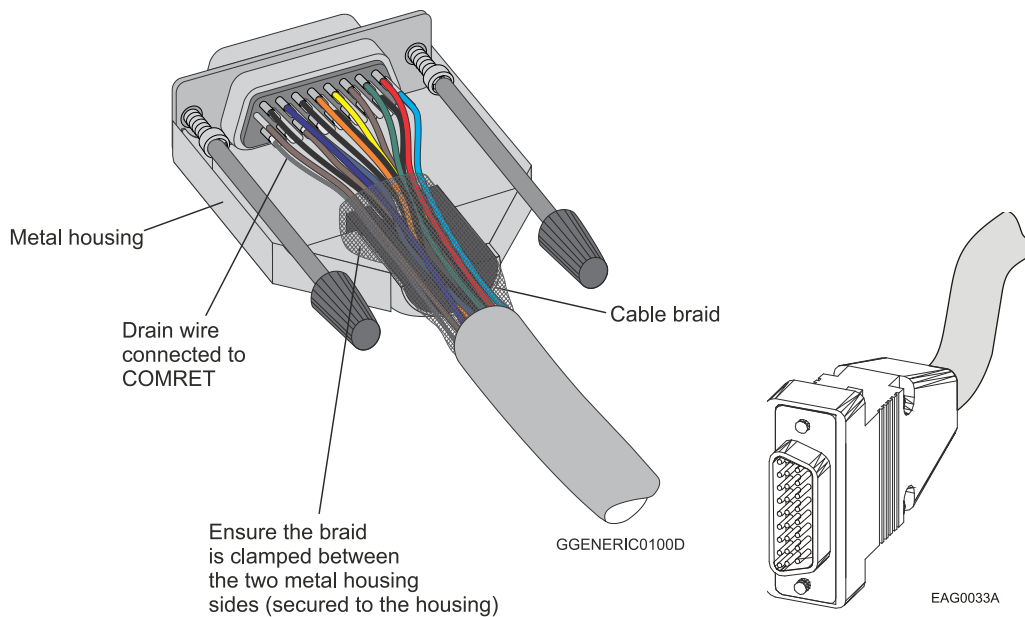

Figure 4: D-Type Cable Assemblies

5. Use only a D-Sub connector with a **metal housing** (Figure 4).
6. Make sure the braid shield is in tight contact with the metal housing of the D-type connector (Figure 4).



6.1.2 Feedback Cable Port A and Port B Connector

1. On the motor side connections, ground the shield to the motor chassis.
2. At least One COMRET (Common Return) must be connected to the PE.

Implement the following steps to connect the COMRET to the PE:

- a. At the drive, connect the feedback drain wire to one of the COMRET terminals in the D-Type feedback connector (Figure 5).
- b. At the motor, connect the feedback cable drain wire to the GND motor chassis terminal of the feedback connector.

The drawings below display two earth connections.

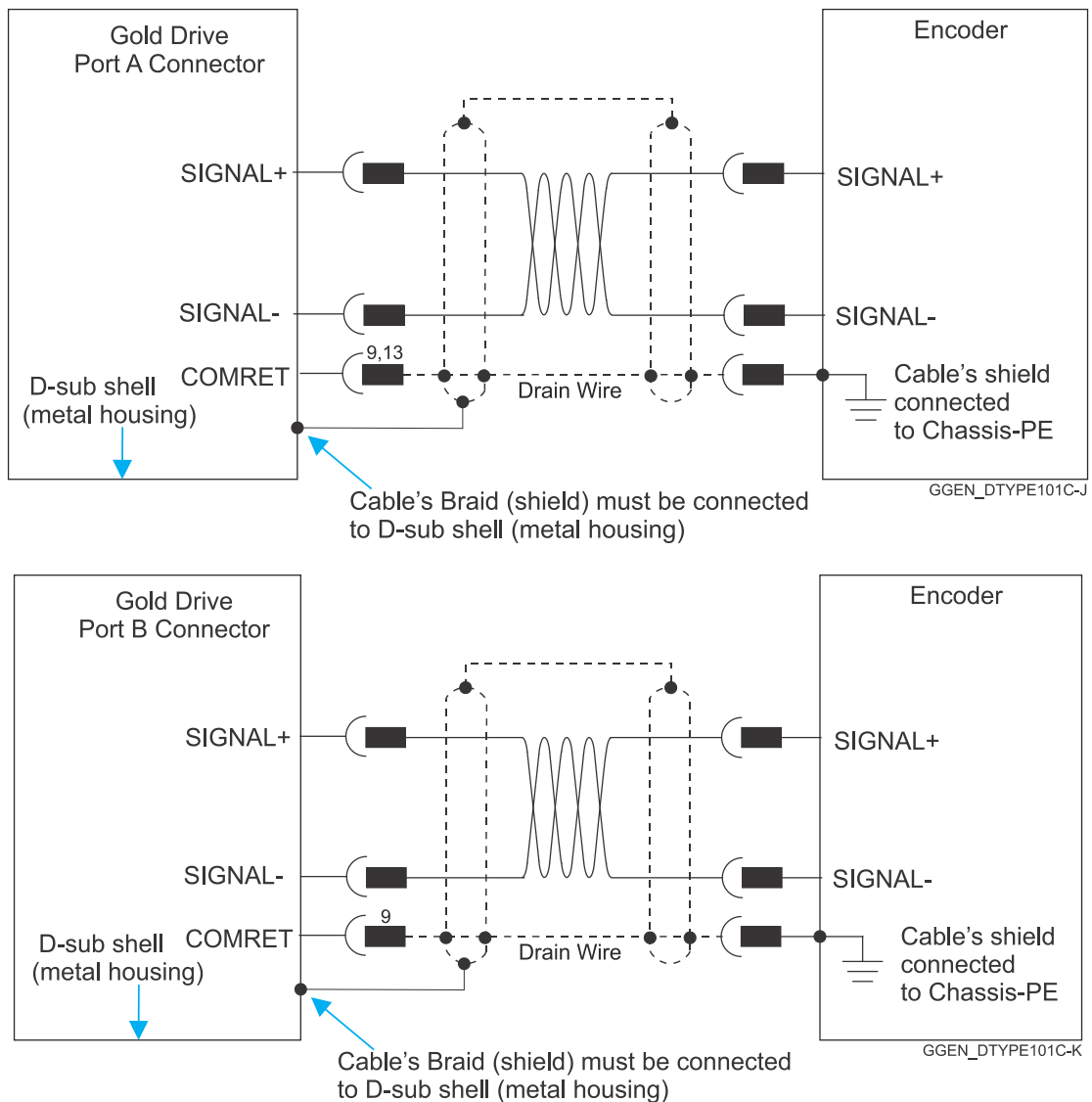

Figure 5: Feedback Port A and B Cable Assemblies



6.1.3 Feedback Cable Port C Connector

1. At the controller side connections, follow the controller manufacturer's recommendations concerning the shield.
2. The connection of the Drain wire to the Port C is not mandatory.

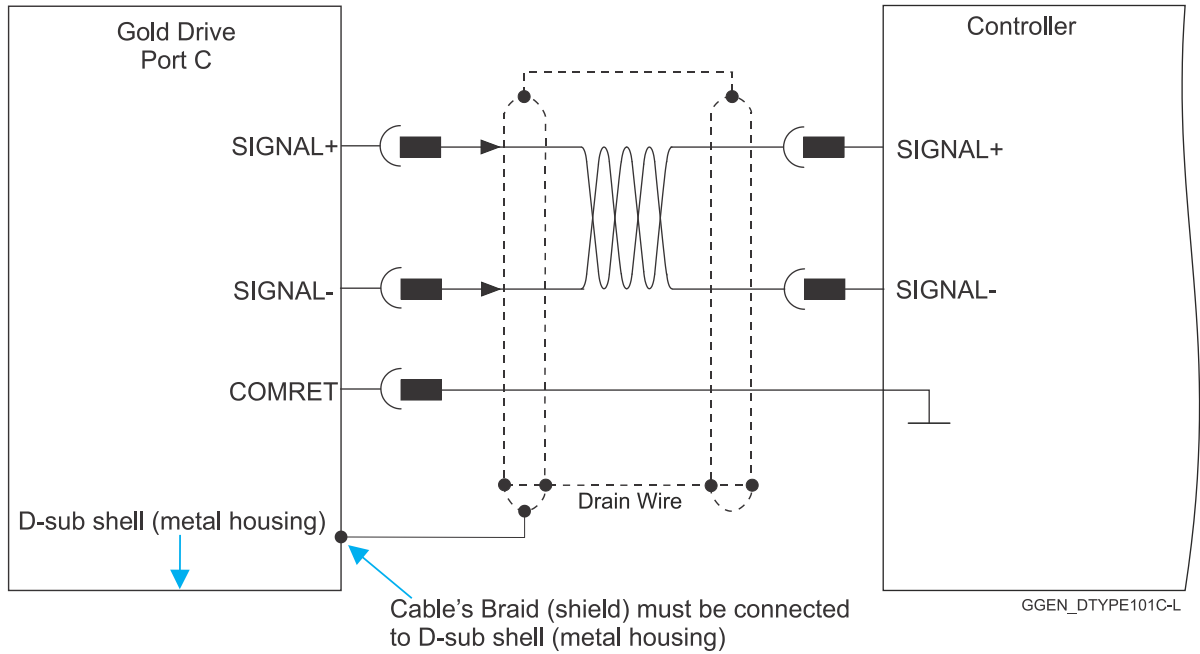

Figure 6: Feedback Port C Cable Assemblies

6.1.4 IO Cable Connector

It is recommended to use shielded cable, but is not mandatory.

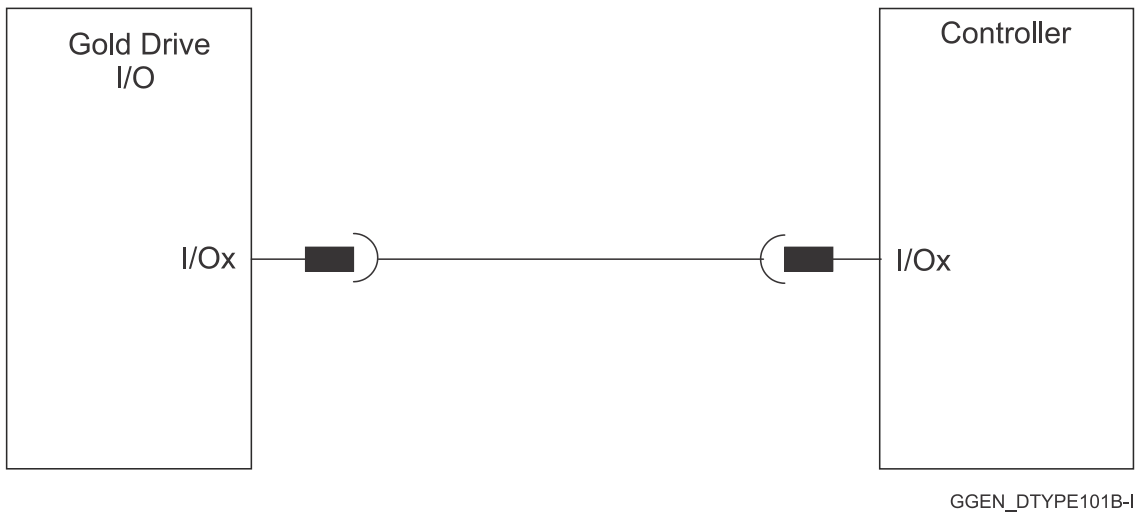

Figure 7: Feedback IO Cable Assemblies



6.1.5 STO (Port C) Cable Connector

It is recommended to use shielded cable, but is not mandatory.

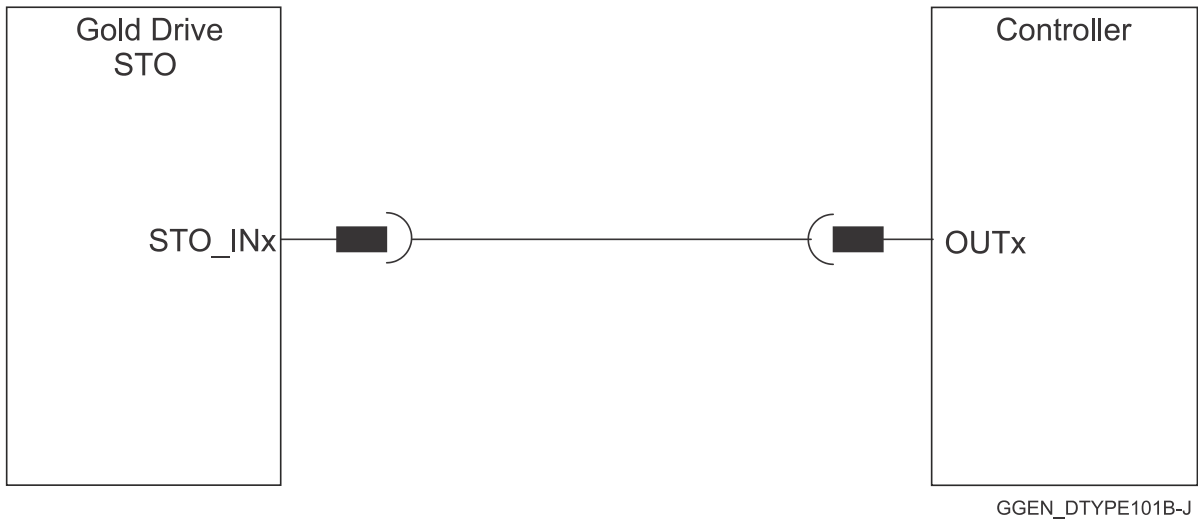
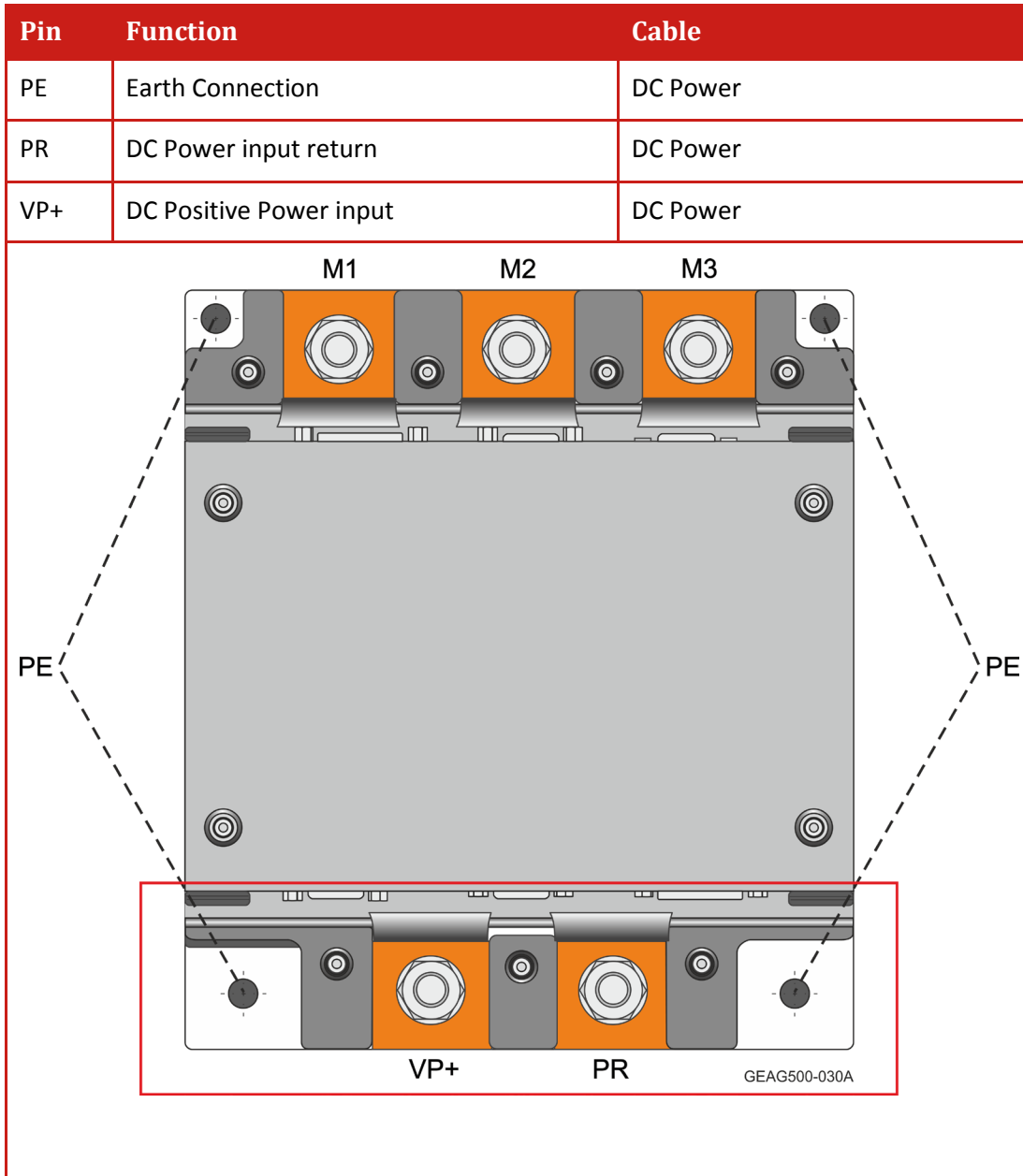

Figure 8: STO Cable Assemblies



6.2 Main Power and Control Supply

The Gold Eagle 550/650 receives power from mains DC power source and delivers power to the motor.





6.2.1 Main Power with Control Backup(VCB) Topology

The Gold Eagle 550/650 operates with only one power supply VP+ and PR. The DC power for the Gold Eagle 550/650 can be delivered from any DC voltage source, either directly from a battery or from an AC rectifying unit.

The Power stage of the Gold Eagle 550/650 is fully isolated according to the UL61800-5-1, from both the Control Stage and heat-sink (PE). **This isolation allows the user to connect the common of the control section to the PE, a connection which significantly contributes to proper functionality, safety and EMI immunity, leading to better performance of the Gold Eagle 550/650.**

The Control section voltages are derived directly from the main power supply (VP+ and PR) by an internal SMPS. The VCB Control Backup supply is used to power the control section, if required, when the VP+ is disconnected.

The following figure describes a power supply for Servo drives with sufficient internal capacitance and shunt regulator to handle power flow in both directions to-and-from the motor. The following figure describes this connection of main power and control power.

When operating from a battery, there is no need for additional capacitance on the DC bus.

Note: The Gold Eagle 550/650 operates with only the main power (VP+ and PR) connected. The VCB Supply is used in case the VP+ is disconnected and the control has to be kept powered (for restoring parameters, keeping position data, and logic).

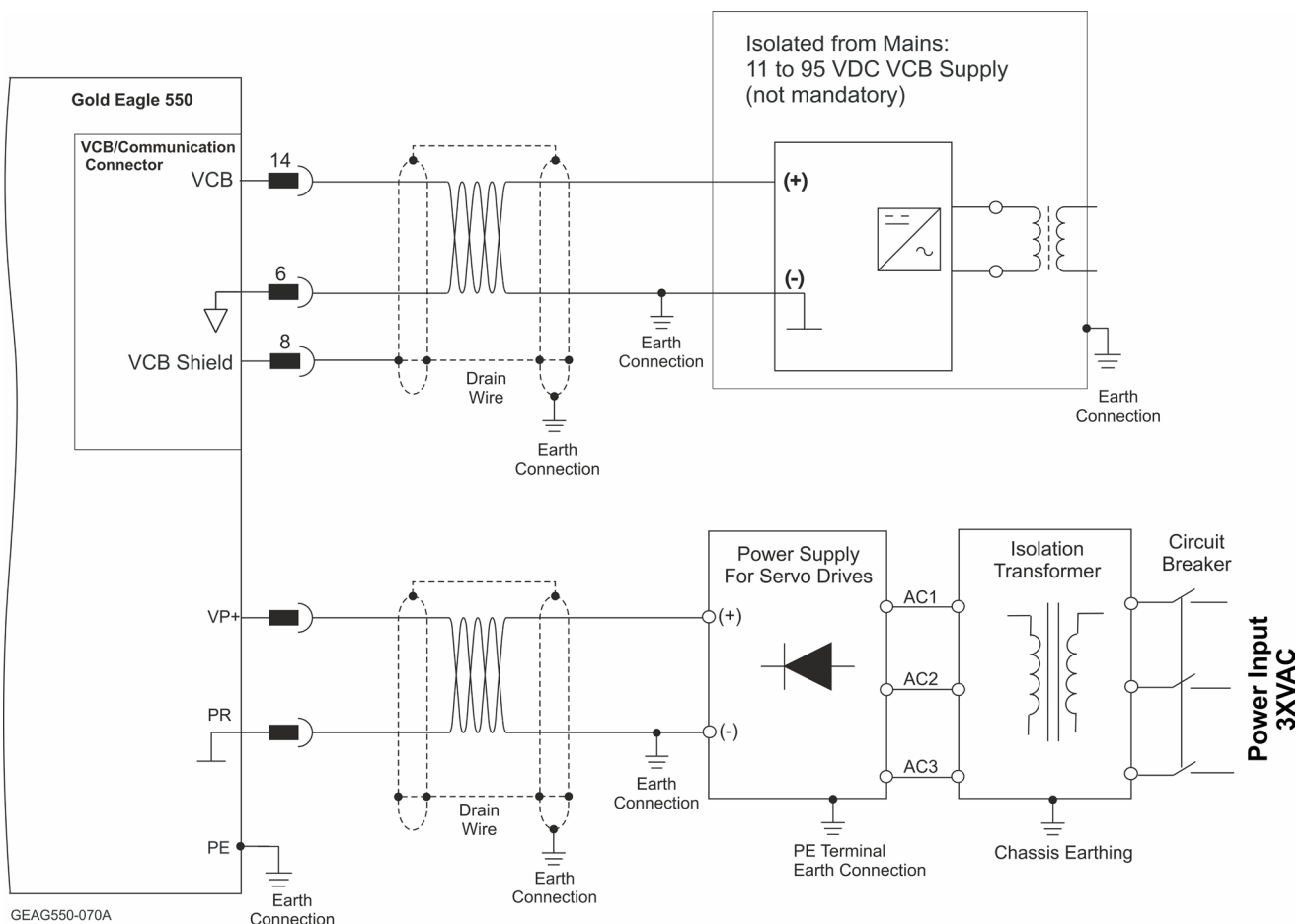

Figure 9: Separate VP and VCB Supplies Connection Diagram



6.2.2 DC Power

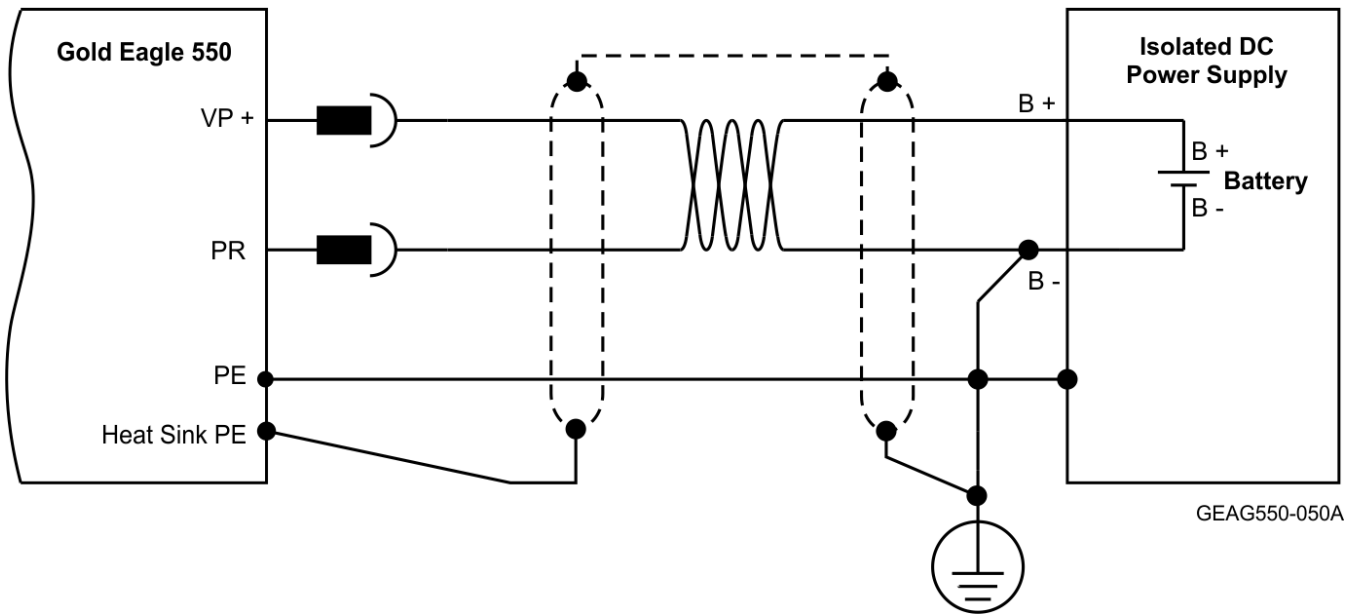

Figure 10: Battery Connection Topology



Caution: When using batteries, it is recommended to connect the negative pole to the PE. When doing so, the charger of the battery **must** be isolated from the mains by an isolation transformer.

To connect to an isolated DC power supply:

1. For best immunity, it is highly recommended to use twisted cables for the DC power supply cable. A 3-wire shielded cable should be used. The gauge is determined by the actual current consumption of the motor.
2. Connect both ends of the cable shield to the closest ground connection, one end near the power supply and the other end to the PE terminal on the Gold Eagle 550/650's heat sink.
3. For safety reasons connect the PR of the power supply to the closest ground connection in the power supply side.
4. Connect the appropriate terminal lugs from the DC Power Input cables to the VP+, PR, and PE terminals on the Gold Eagle 550/650. Refer to section 6.4 Connecting the DC Power and the Motor Power Cables, and in particular, Table 2: Connecting the Main Power and Motor Cables.
 - a. Mount the power supply cable into the drive using the recommended Terminal Lug (FLEX) (Stud hall size: 10 mm (3/8")) 2/0 - 4/0 AWG, M10 flat washer, M10 spring washer, and secure with an M10 nut (to the drive). The required M10 nut torque is typically 15 to maximum 20 Nm.
 - b. Install the recommended PE 2/0 - 4/0 AWG wire to the drive, using a barrel connector, M8 flat washer, M8 spring washer, and secure with an M8 x 20 mm (minimum) head cup Allen screw to the heat-sink. The required M8 screw torque is typically 15 to maximum 20 Nm.
5. Before applying power, first verify that the polarity of the connection is correct.



6.2.3 Control Backup Supply(VCB)

Pin	Function	Function
14	VCB Input Positive	DC Power
6	COMRET	DC Power
8	VCB Shield	Drain wire cable

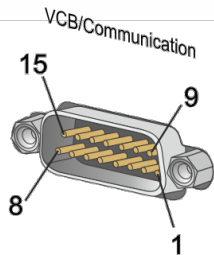
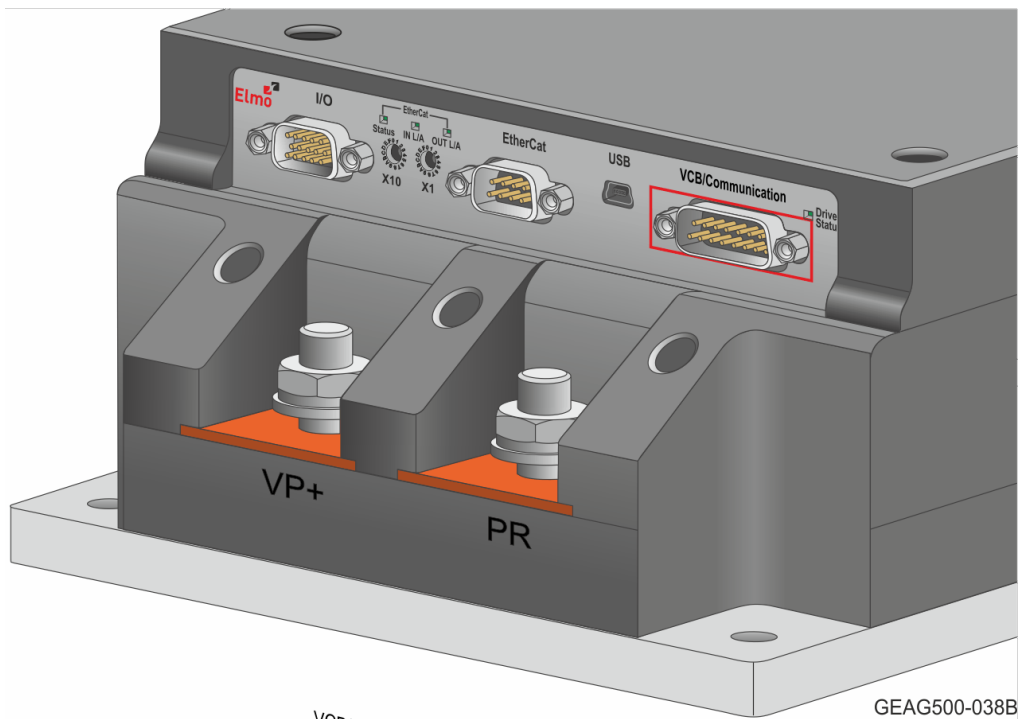

Table 1: VCB Supply Pins and Polarity

A smart control supply(VCB) algorithm enables the Gold Eagle 550/650 to operate with the main power supply only, *with no need for a VCB supply voltage to supply the drive's logic section.*

If backup functionality is required to store control parameters in the event of a mains power outage, then an external control isolated supply(VCB) is connected to the Gold Eagle 550/650.

Connect the control power supply as described below.

To connect the power supply:

1. Use a 24 AWG twisted pair shielded cable. The shield should have copper braid. The source of the VCB supply must be isolated from the mains.
2. For safety and EMI reasons, connect the return of the VCB supply to the closest ground (PE) in the power supply side.
3. Connect the cable shield to the closest ground (PE) near the power source.



4. Connect the drain wire shield to the Terminal No. 8 (PE).
5. Before applying power, first verify that the polarity of the connection is correct.

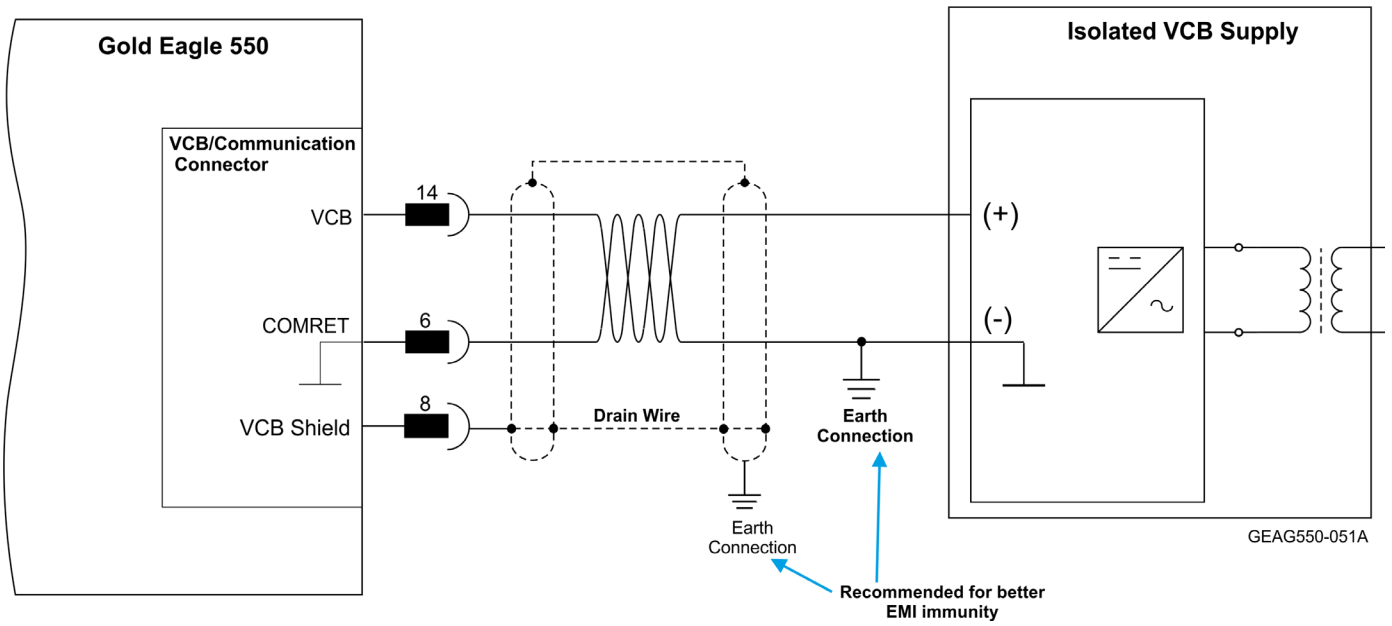

Figure 11: VCB Supply Connection Diagram



6.3 Motor Power Connector Pinouts

See Chapter 8 in the in the MAN-G-Panel Mounted Drives Hardware manual for full details.

Pin	Function	Cable	
		Brushless Motor	Brushed DC Motor
M3	Motor phase	Motor	Motor
M2	Motor phase	Motor	Motor
M1	Motor phase	Motor	N/C
PE	Earth Connection	Motor	Motor

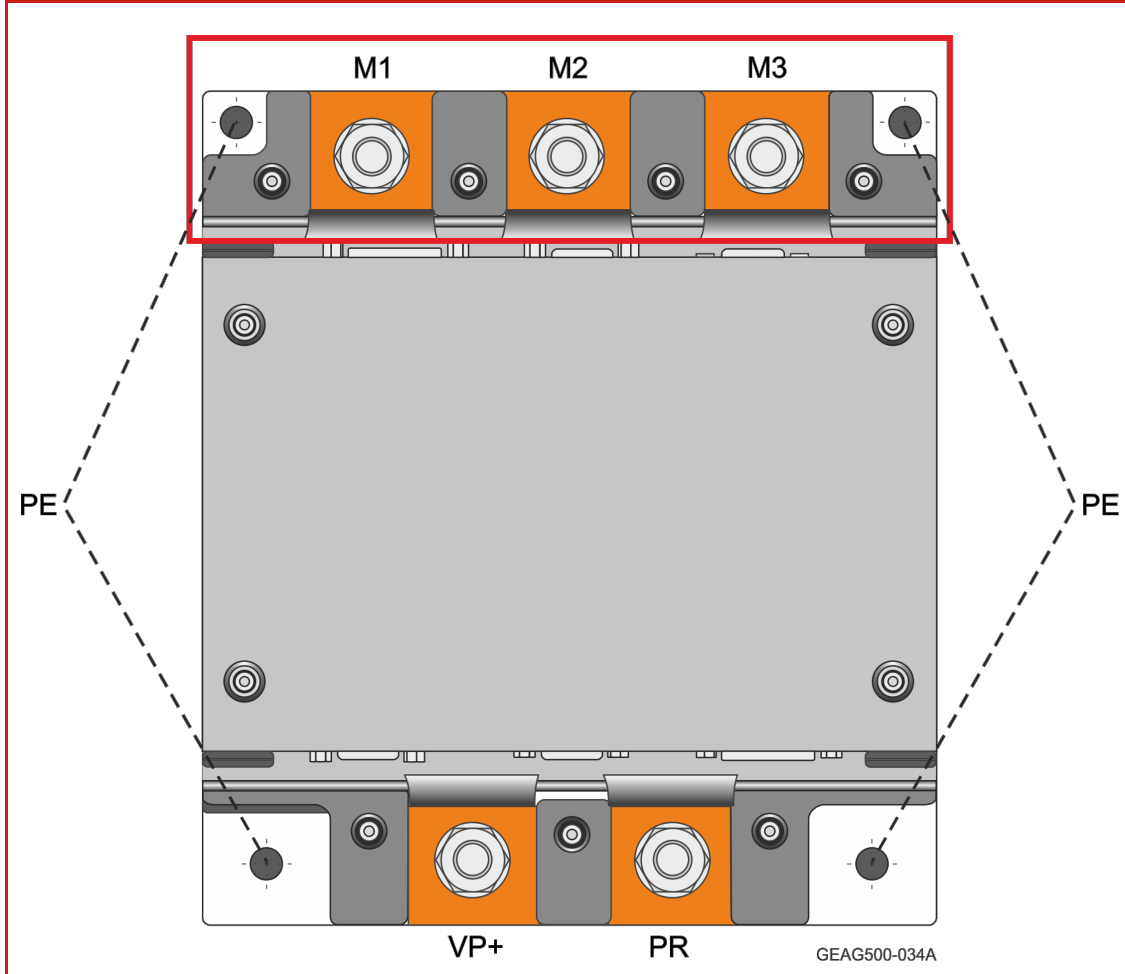

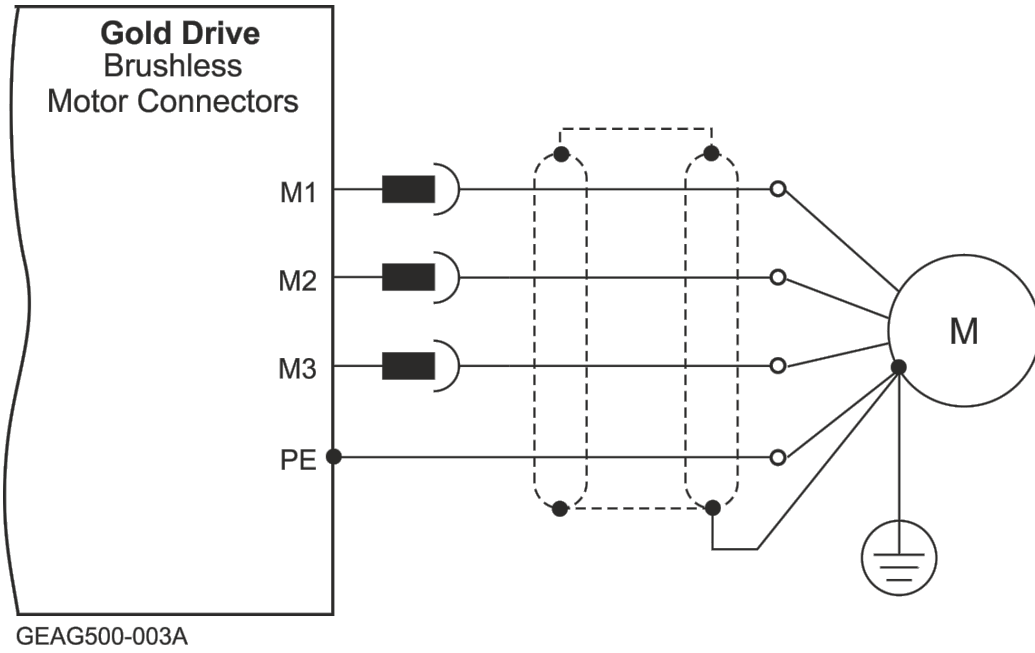

Figure 12: Brushless Motor Power Connection Diagram

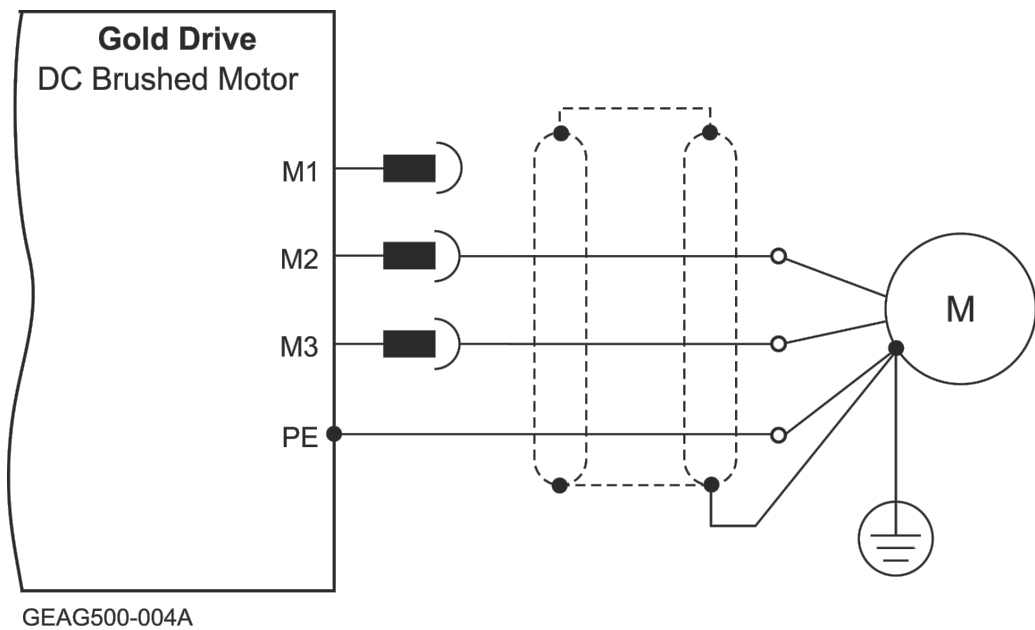

Figure 13: Brushed Motor Power Connection Diagram



6.4 Connecting the DC Power and the Motor Power Cables

This section describes the installation of the cable terminal lugs for both the Main Power Cables to VP+, PR, and PE terminals on the Gold Eagle 550/650, and the Motor Power cables to the M1, M2, M3, and PE terminals on the Gold Eagle 550/650.

Note: When connecting several motors, all the motor phases must be connected in an identical sequence.

Step 1: PE Earth Connection

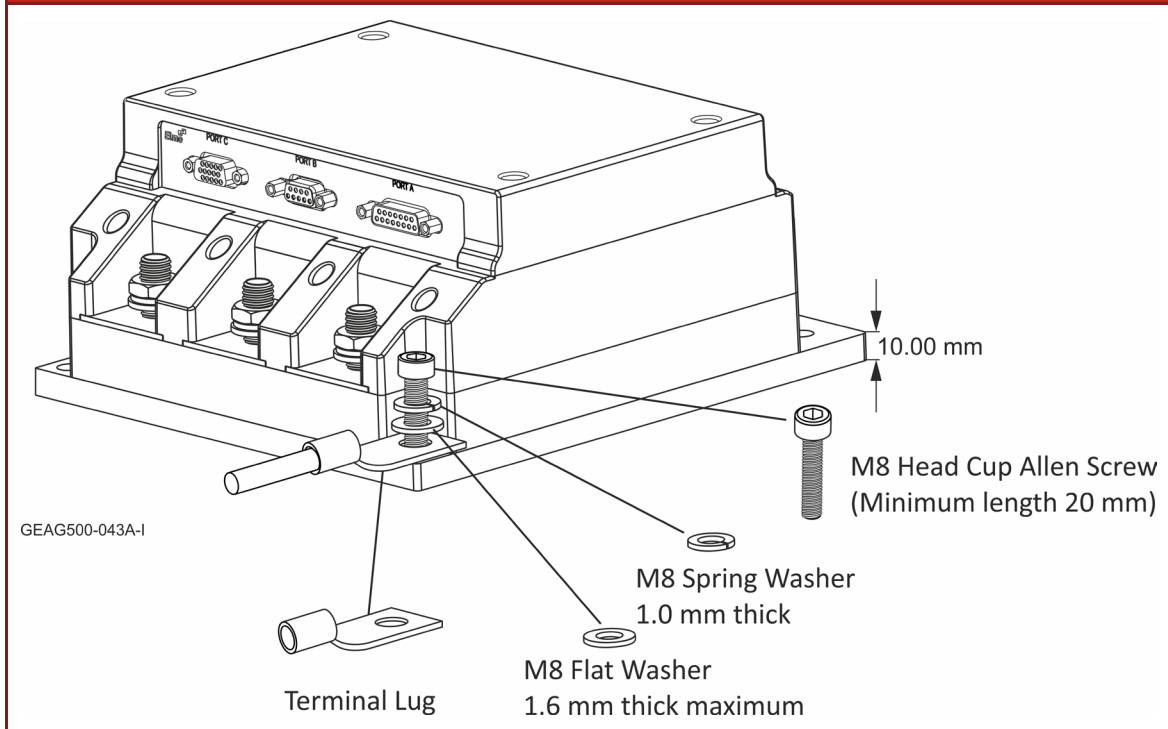

Step 2: Power and Motor Connection

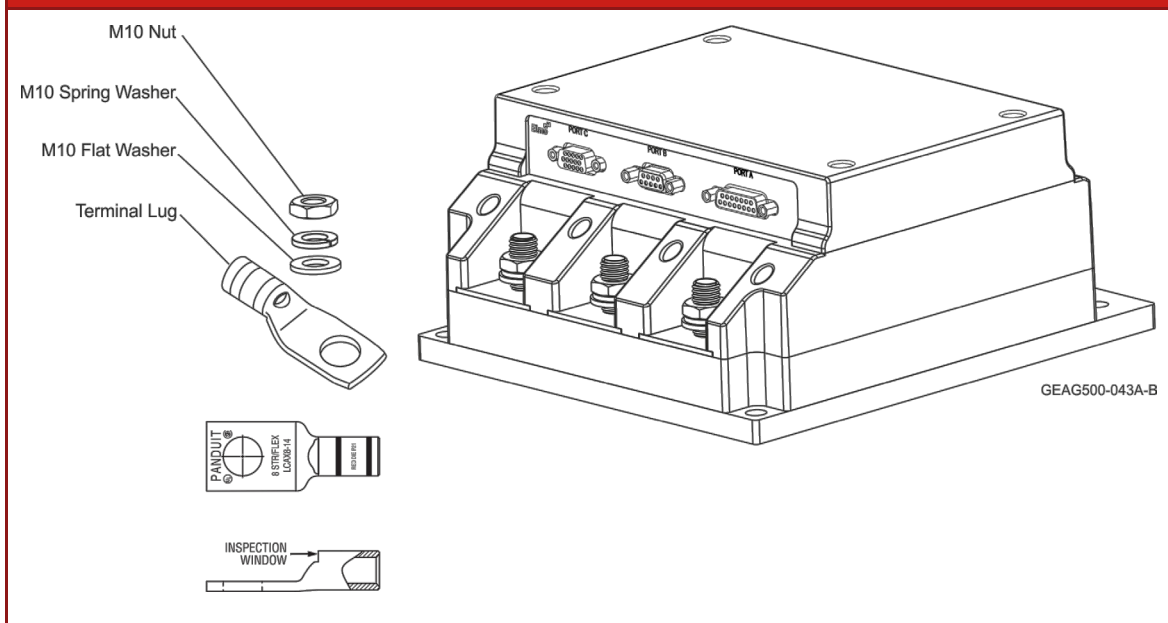



Step 3: Power and Motor Connection

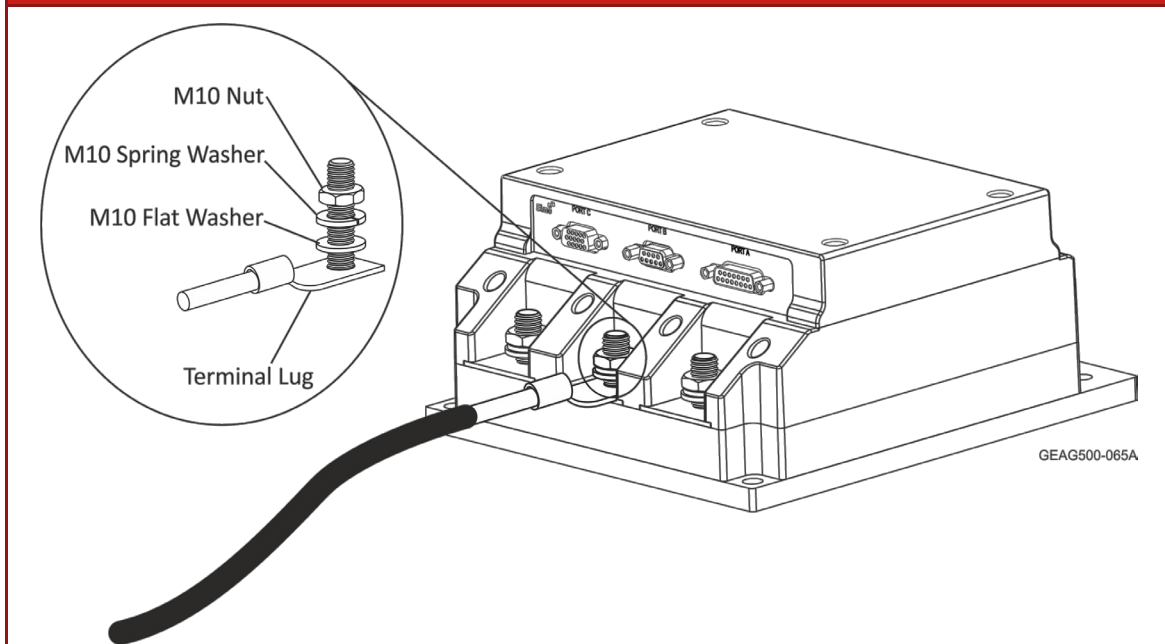

Table 2: Connecting the Main Power and Motor Cables

6.4.1 Motor Power

1. For best immunity, it is highly recommended to use a 4-wire shielded (not twisted) cable for the motor connection. The gauge is determined by the actual RMS current consumption of the motor.

Connect the cable shield to the closest ground connection at the motor end.

For better EMI performance, the shield should be connected to Earth Connection (heat sink mounting holes).

2. Ensure that the motor chassis is properly earthed.
3. Connect the appropriate terminal lugs from the Motor Power cables to the M1, M2, M3, and PE terminals on the Gold Eagle 550/650.

The phase connection is arbitrary as Elmo Application Studio (EAS II) will establish the proper commutation automatically during setup. When tuning a number of drives, you can copy the setup file to the other drives and thus avoid tuning each drive separately. In this case the motor-phase order must be the same as on the first drive.

- a. Install the motor cable to the drive using the recommended Terminal Lug (FLEX) (Stud hole size: 10 mm (3/8")) 2/0 - 4/0 AWG, M10 flat washer, M10 spring washer, and secure with an M10 nut (to the drive). The required M10 nut torque is typically 15 to maximum 20 Nm.
- b. Install the recommended PE 2/0 - 4/0 AWG wire to the drive, using a barrel connector, M8 flat washer, M8 spring washer, and secure with an M8 x 20 mm (minimum) head cup Allen screw to the heat-sink. The required M8 screw torque is typically 15 to maximum 20 Nm.



6.5 Port A

See Section 10.3 in the in the MAN-G-Panel Mounted Drives Hardware manual for full details.

Port A	Incremental Encoder		Absolute Serial Encoder	
Pin	Signal	Function	Signal	Function
12,4	+5V	Encoder +5V supply	+5V	Encoder +5V supply
3,9,11,13	COMRET	Common return	COMRET	Common Return
6	PortA_ENC_A+	Channel A+	ABS_CLK+	Abs encoder clock +
5	PortA_ENC_A-	Channel A-	ABS_CLK-	Abs encoder clock -
15	PortA_ENC_B+	Channel B+	ABS_DATA+	Abs encoder data +
14	PortA_ENC_B-	Channel B-	ABS_DATA-	Abs encoder data -
8	PortA_ENC_INDEX+	Index+	Reserved	Reserved
7	PortA_ENC_INDEX-	Index-	Reserved	Reserved
2	HA	Hall sensor A	HA	Hall sensor A
10	HB	Hall sensor B	HB	Hall sensor B
1	HC	Hall sensor C	HC	Hall sensor C

Pin Positions

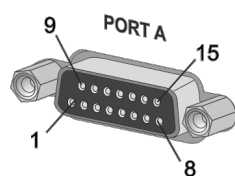
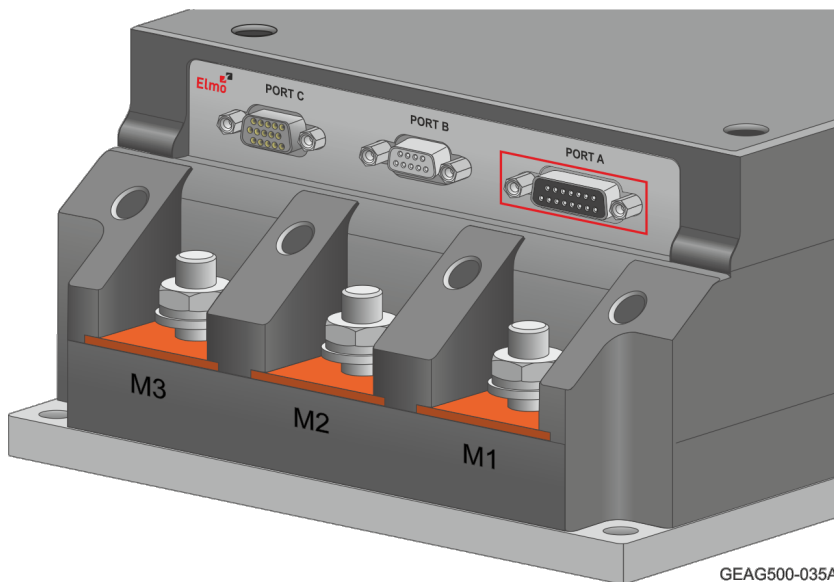

15-Pin D-Type Female Connector

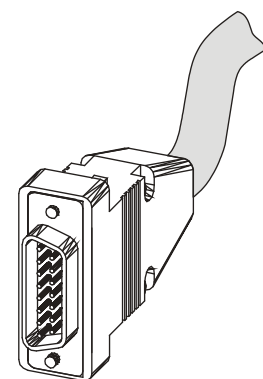

15-Pin D-Type Male Connector

Table 3: Port A Pin Assignments



6.5.1 Incremental Encoder

The following figure describes the connections at Port A for the Incremental encoder.

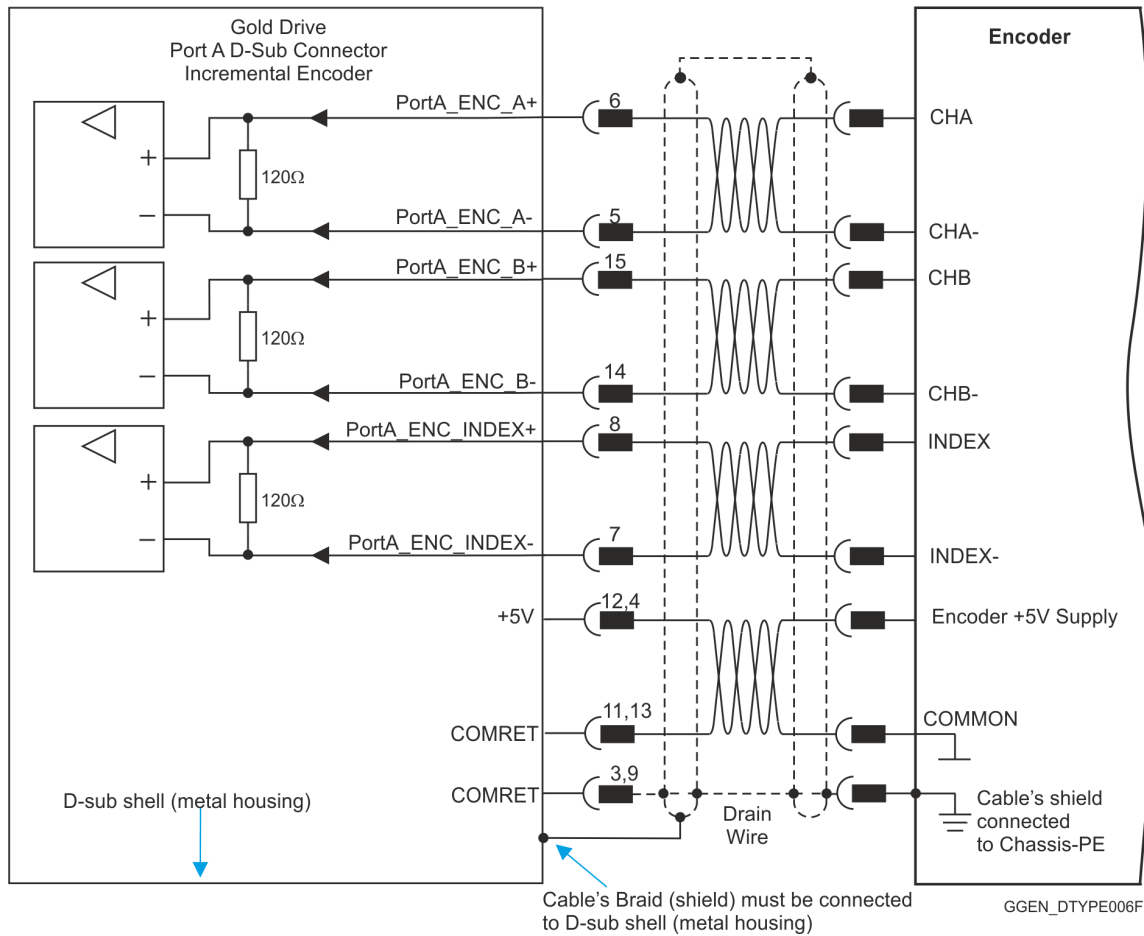

Figure 14: Port A D-Type Incremental Encoder Input – Recommended Connection Diagram

6.5.2 Hall Sensor

The following figure describes the connections at Port A for the Hall Sensor.

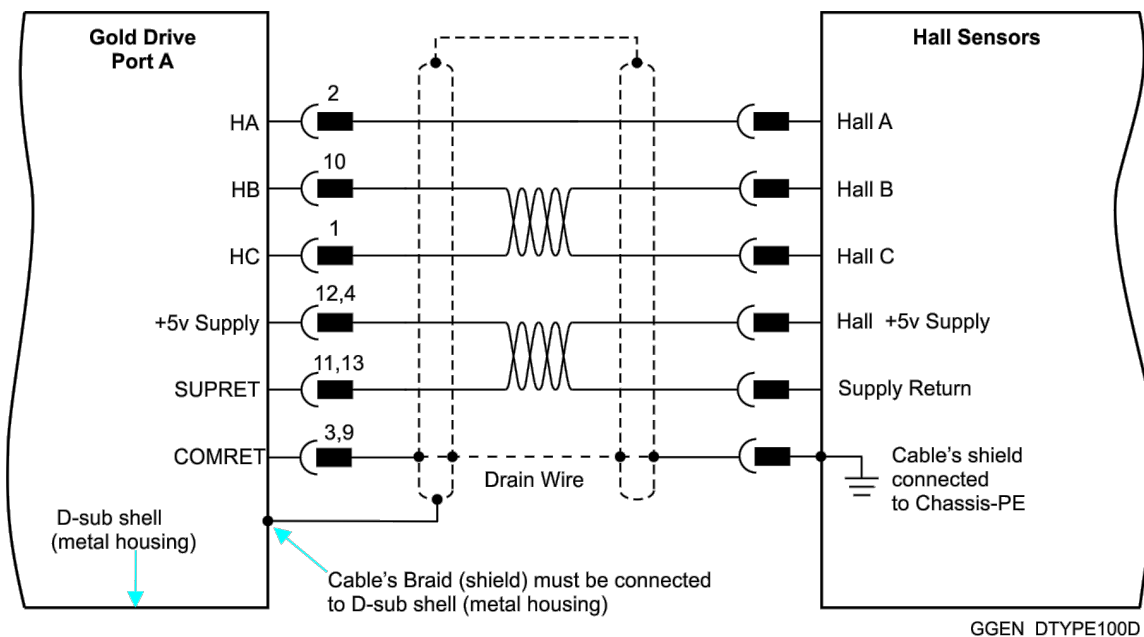

Figure 15: Hall Sensor Connection Diagram



6.5.3 Absolute Serial Type Encoder

The following figures describe the connections at Port A for the Absolute Serial type encoders.

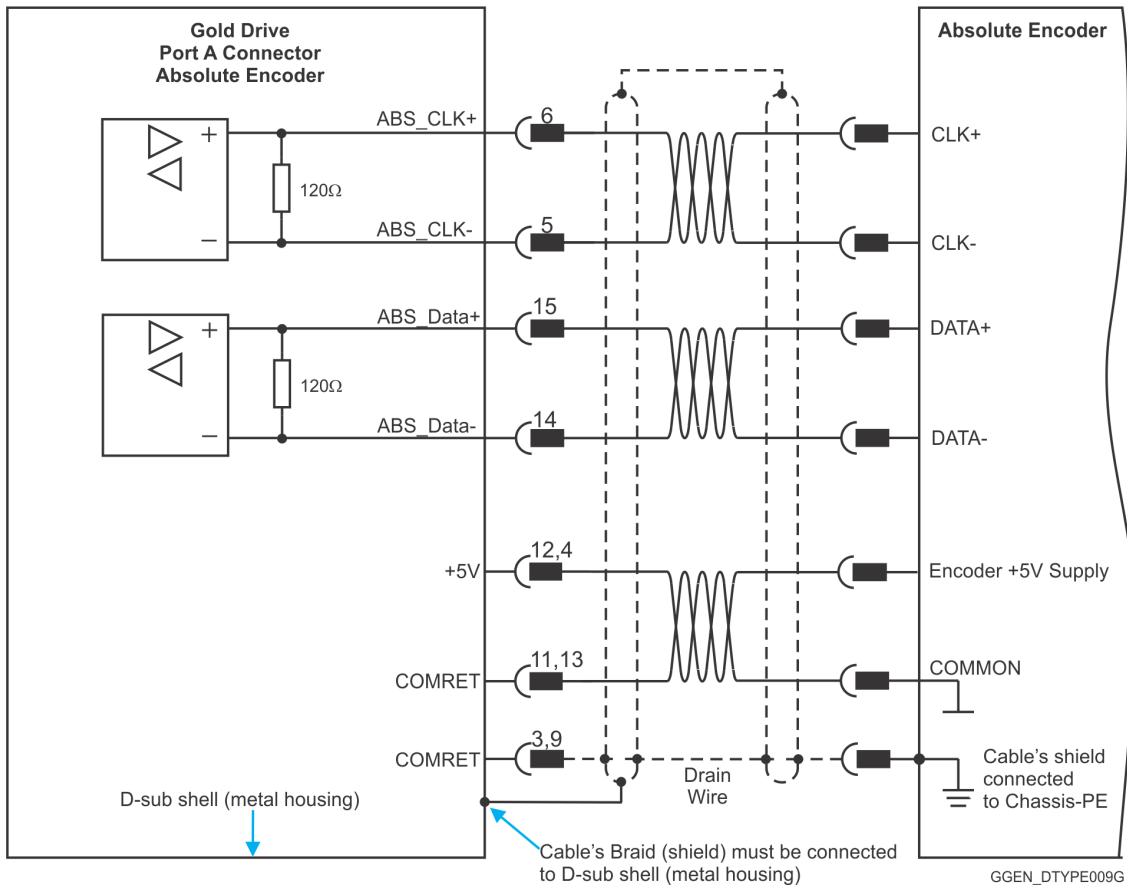

Figure 16: Absolute Serial Encoder – Recommended D-Type Connection Diagram for EnDAT, Biss, and SSI

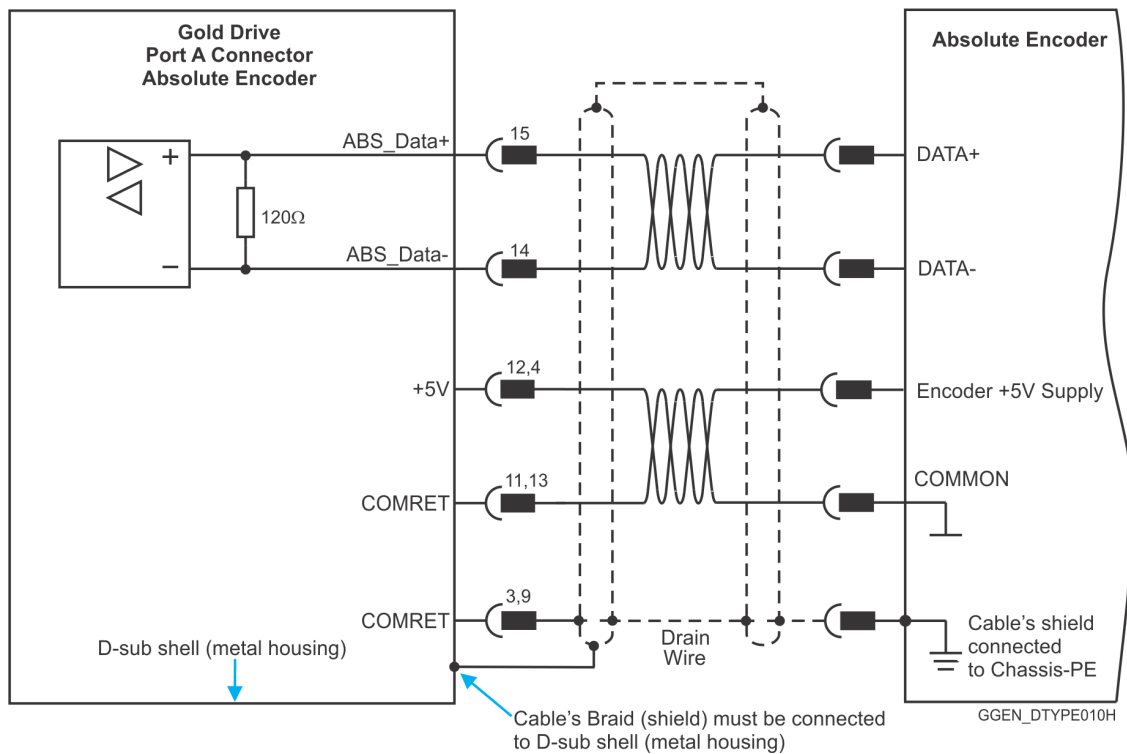

Figure 17: Absolute Serial Encoder – Recommended D-Type Connection Diagram for Sensors Supporting Data Line Only (NRZ types, e.g., Panasonic / Mitutoyo / Sanyo Danki / Tamagawa)

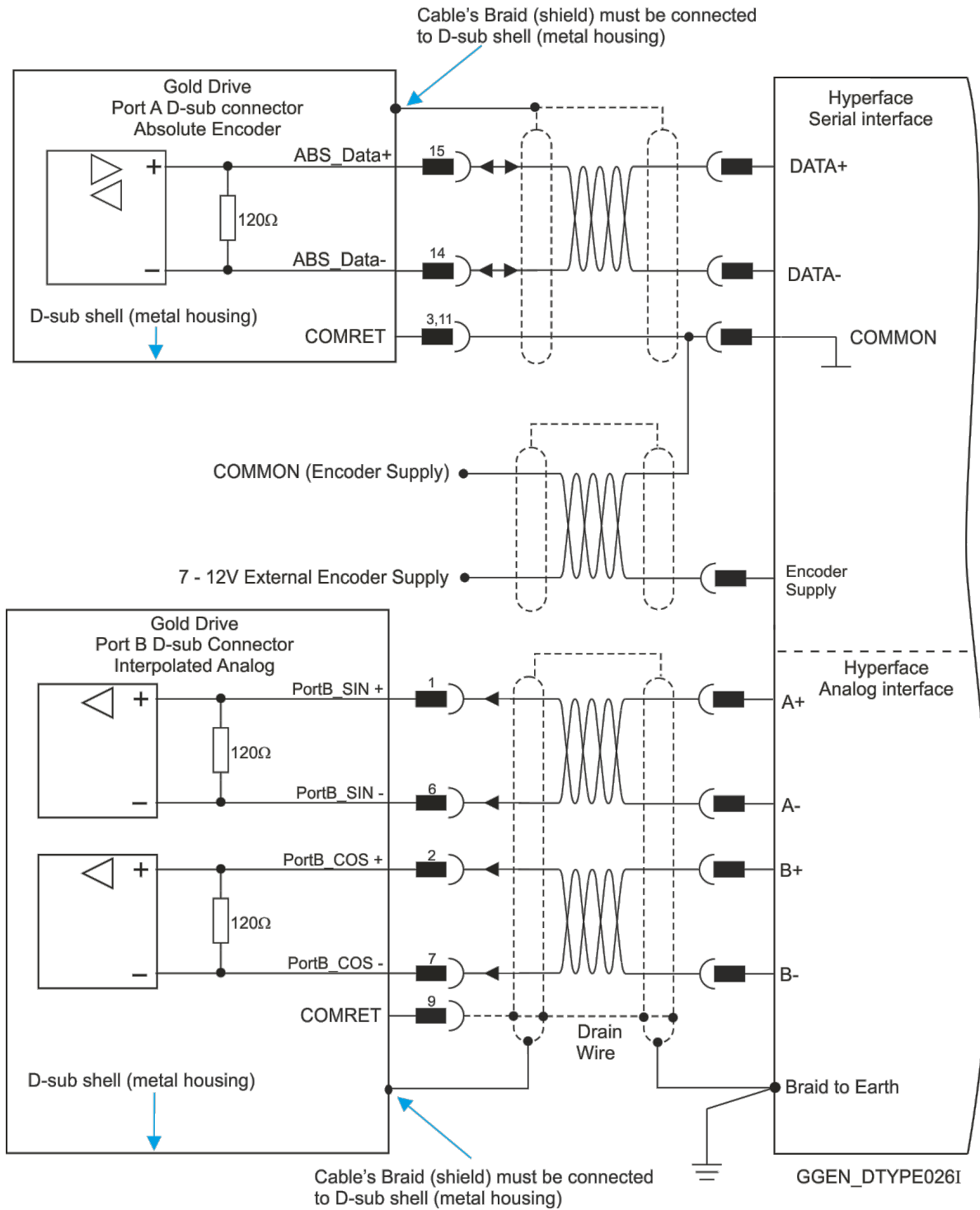

Figure 18: Absolute Serial Encoder – Recommended D-Type Connection Diagram for Stegmann Hiperface

Note: When the Hiperface protocol is used, the RS-232 connection is not available.



6.6 Port B Connector

See Section 10.4 in the in the MAN-G-Panel Mounted Drives Hardware manual for full details.

Port B Incremental or Interpolated Analog Encoder			Resolver	
	G-EAGX550/100XEXX		G-EAGX550/100XRXX	
Pin	Signal	Function	Signal	Function
4	+5V	Encoder +5V supply	NC	NC
5,9	COMRET	Common Return	COMRET	Common Return
1	PortB_ENC_A+/SIN+	Channel A+ / Sine+	SIN+	Sine+
6	PortB_ENC_A-/SIN-	Channel A- / Sine-	SIN-	Sine-
2	PortB_ENC_B+/COS+	Channel B+ / Cosine+	COS+	Cosine+
7	PortB_ENC_B-/COS-	Channel B- / Cosine-	COS-	Cosine-
3	PortB_ENC_INDEX+	Index+	RESOLVER_OUT+	Vref f=1/TS, 50 mA Max.
8	PortB_ENC_INDEX-	Index -	RESOLVER_OUT-	Vref complement f= 1/TS, 50 mA Max.

Pin Positions

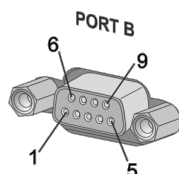
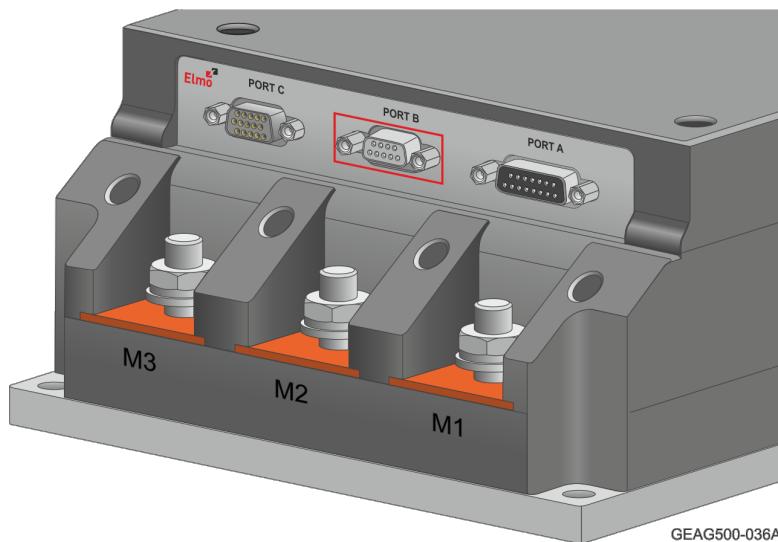

9-Pin D-Type Female Connector

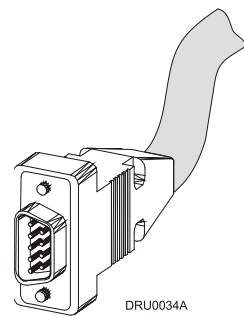

9-Pin D-Type Male Connector

Table 4: Port B Pin Assignments



6.6.1 Incremental Encoder

The following figure describes the connections at Port B for the Incremental encoder.

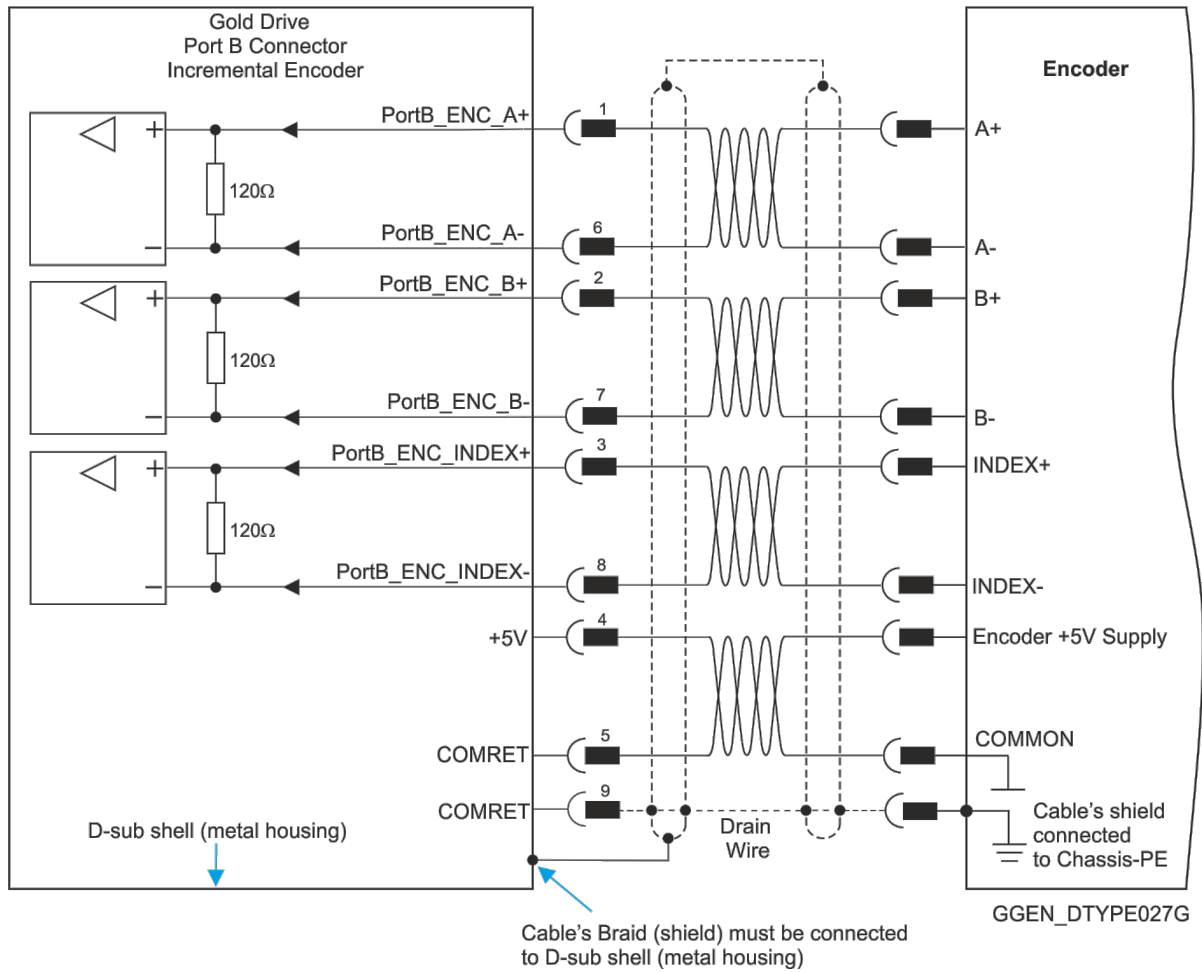

Figure 19: Port B Incremental Encoder Input – Recommended D-Type Connection Diagram



6.6.2 Interpolated Analog Encoder

The following figure describes the connections at Port B for the Interpolated Analog encoder.

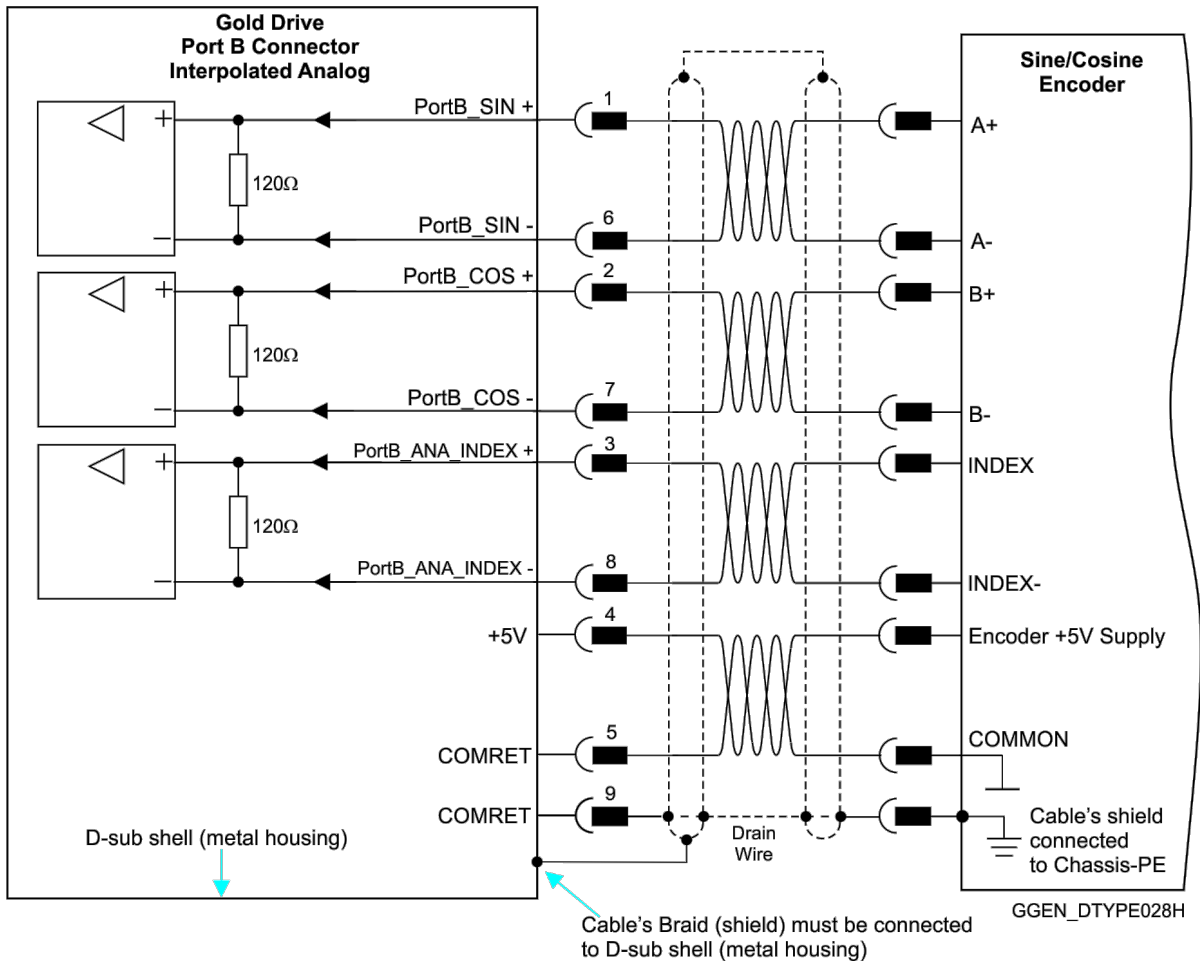

Figure 20: Port B - Interpolated Analog Encoder D-Type Connection Diagram



6.6.3 Resolver

The following figure describes the connections at Port B for the Resolver encoder.

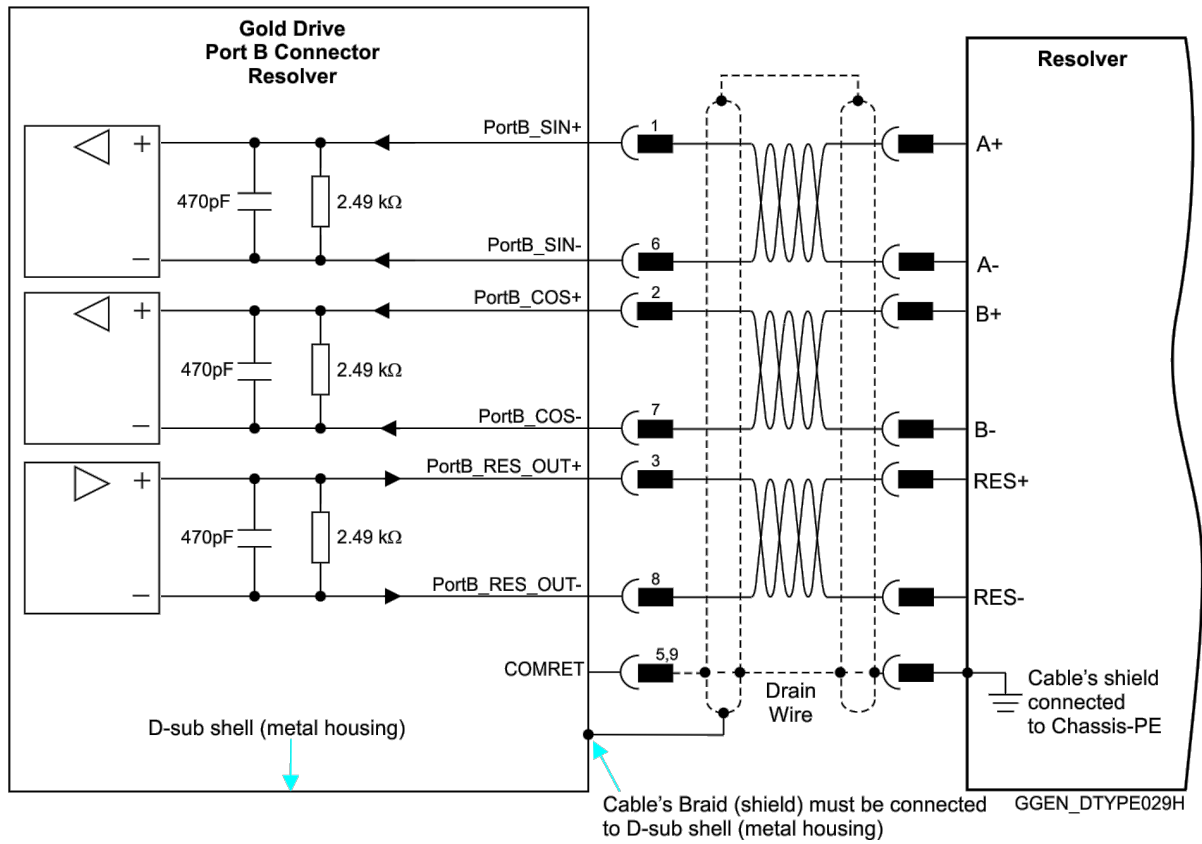

Figure 21: Port B – Resolver D-Type Connection Diagram



6.7 Port C, Analog Input, and STO

The Port C connector includes the following functions:

- Port C: Refer to Sections 10.5 in the in the MAN-G-Panel Mounted Drives Hardware manual for full details
- STO: See Chapter 9 in the in the MAN-G-Panel Mounted Drives Hardware manual for full details.
- Analog input: See Section 11.2 in the in the MAN-G-Panel Mounted Drives Hardware manual for full details.

Pin on Port C	Signal	Function
1	PortC_ENCO_A+	Buffered Channel A+ output/Pulse+/PWM+
2	PortC_ENCO_A-	Buffered Channel A- output / Pulse- / PWM-
3	PortC_ENCO_B+	Buffered Channel B+ output / Dir+
4	PortC_ENCO_B-	Buffered Channel B- output / Dir-
5	PortC_ENCO_Index+	Buffered Channel INDEX+ output
6	STO1	STO 1 input (default 24 V)
7, 12	STO_RET	STO signal return
8	Reserved	Reserved
9	COMRET	Common return
10	PortC_ENCO_Index-	Buffered Channel INDEX- output
11	STO2	STO 2 input (default 24 V)
13	ANLRET	Analog ground
14	ANALOG1-	Analog input 1-
15	ANALOG1+	Analog input 1+



Pin Positions

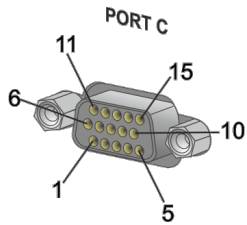
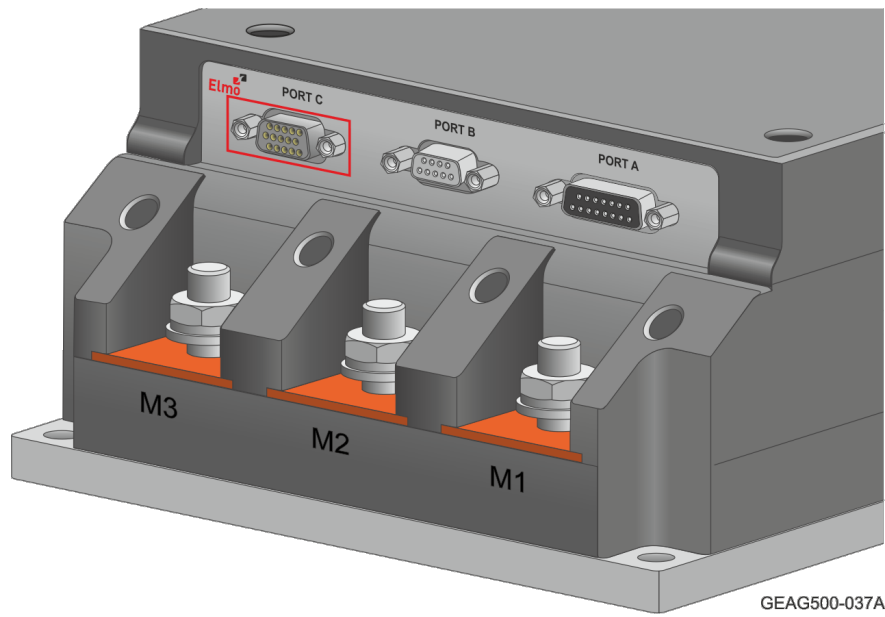

15-Socket High Density D-Type Connector

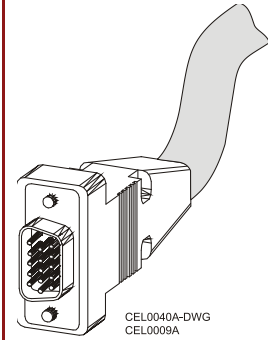

15-Pin High Density D-Type Male Connector

Table 5: Port C Pin Assignments



6.7.1 Port C

The following figure describes the connections at Port C for the Emulated Encoder Differential.

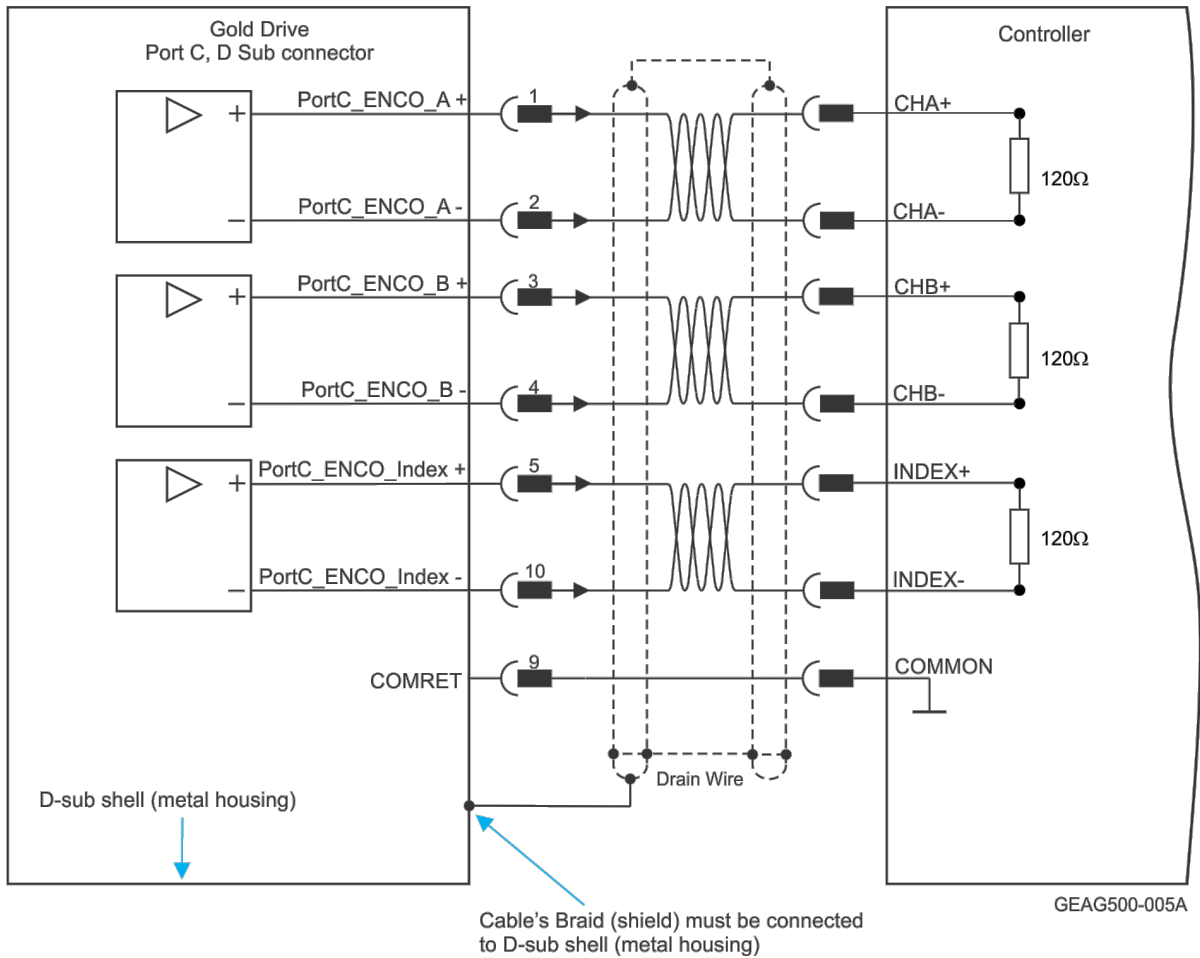

Figure 22: Emulated Encoder Differential Output – Recommended D-Type Connection Diagram

6.7.2 Analog Input

The following circuit describes the internal interface of the Analog input.

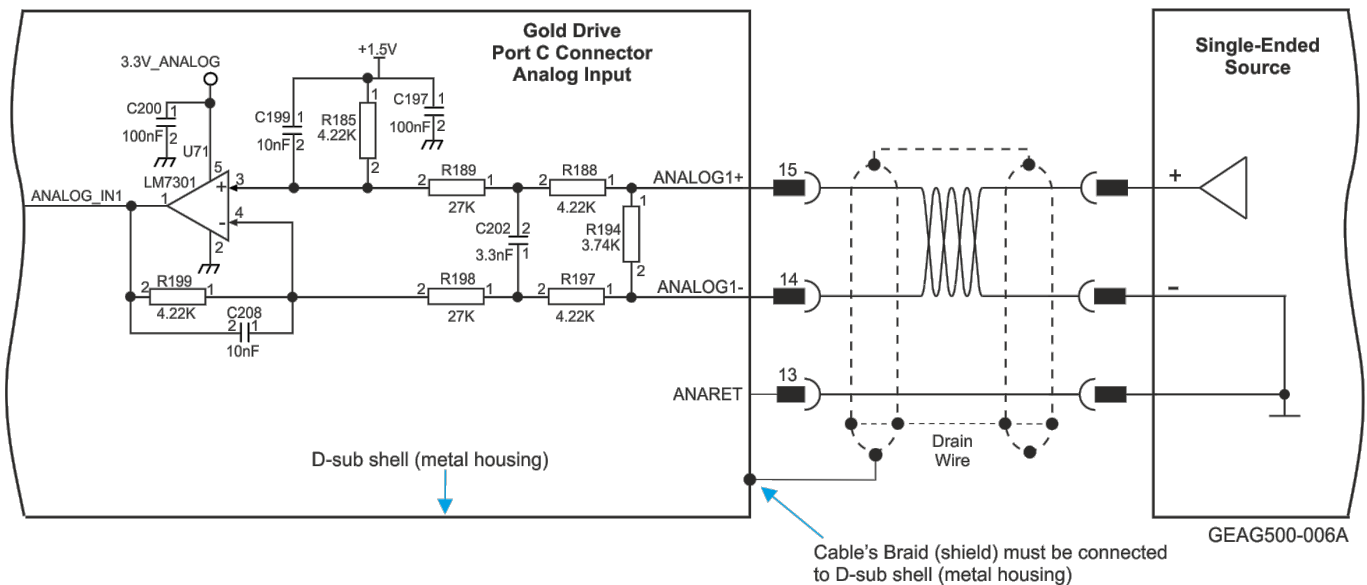

Figure 23: Differential Analog D-Type Input



6.7.3 STO

The following circuits describe the STO wiring options.

6.7.3.1 Source Mode PLC Voltage Level

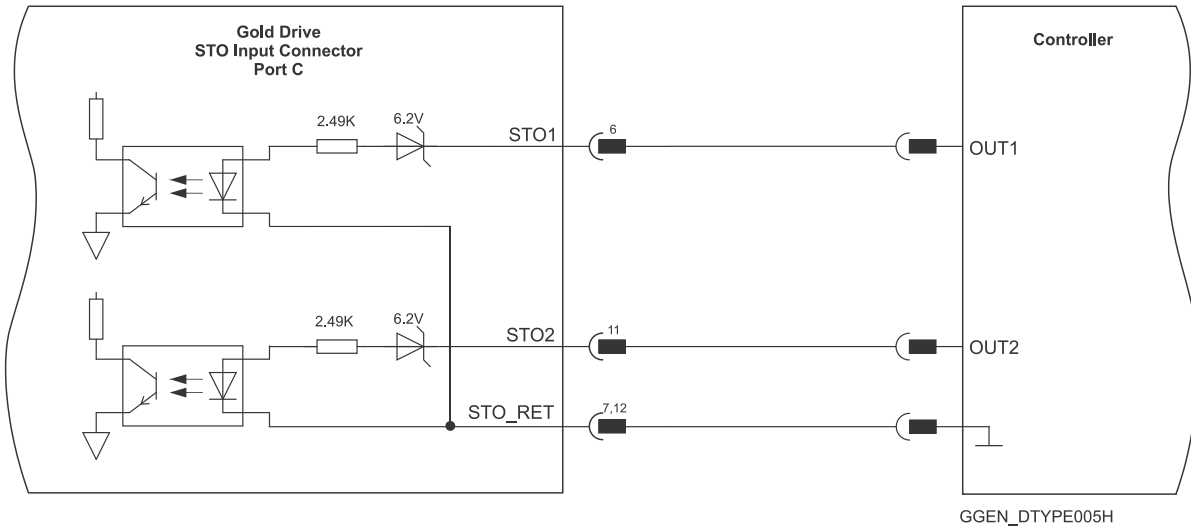

Figure 24: STO D-Type Input Connection – PLC Source Option

6.7.3.2 TTL Mode TTL Voltage Level

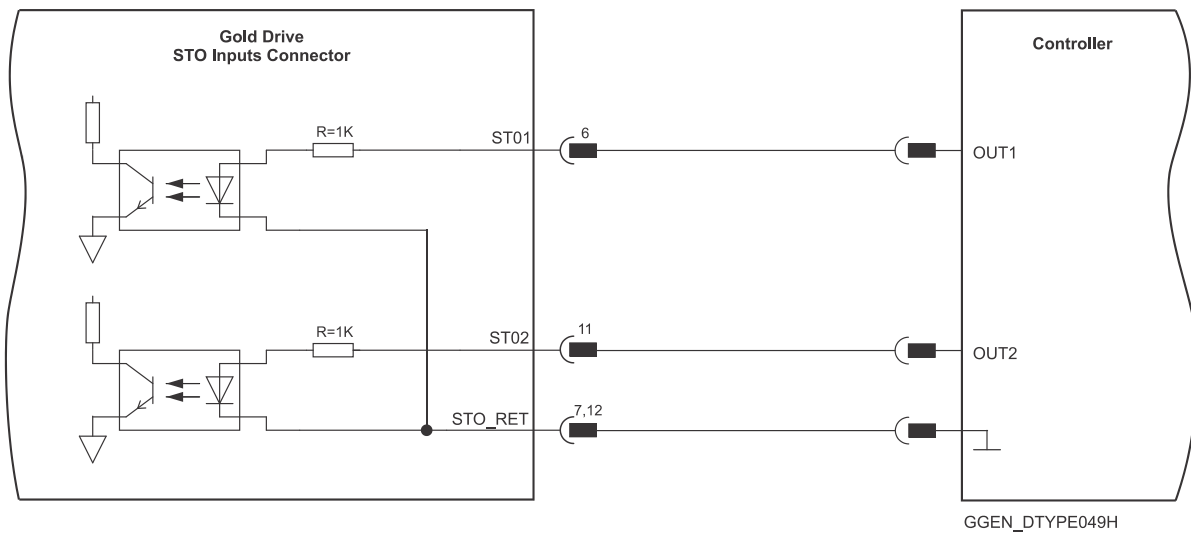

Figure 25: STO Input Connection – TTL Option



6.8 Digital Inputs and Outputs

Refer to Chapter 11 in the in the MAN-G-Panel Mounted Drives Hardware manual for full details.

I/O Pins	Signal	Function
1	IN1	High speed programmable input 1
2	IN2	High speed programmable input 2
7	IN3	High speed programmable input 3
8	IN4	High speed programmable input 4
11	IN5	High speed programmable input 5
12	IN6	High speed programmable input 6 <i>or</i>
		STO OUT Collector in the 0 version
6	INRET1-6	Inputs 1 to 6 return for the Source version
		Positive input 1 to 6 for the Sink version
3	OUT1	Programmable output 1
4	OUT2	Programmable output 2
5	OUT3	Programmable output 3
13	OUT4	Programmable output 4 <i>or</i>
		STO OUT Emitter in the 0 version
10, 15	VDD	Supply for out 1-4
9, 14	VDDRET	Supply return for out 1-4



Pin Positions

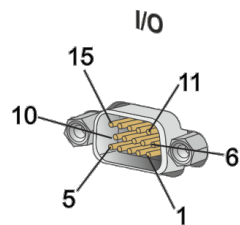
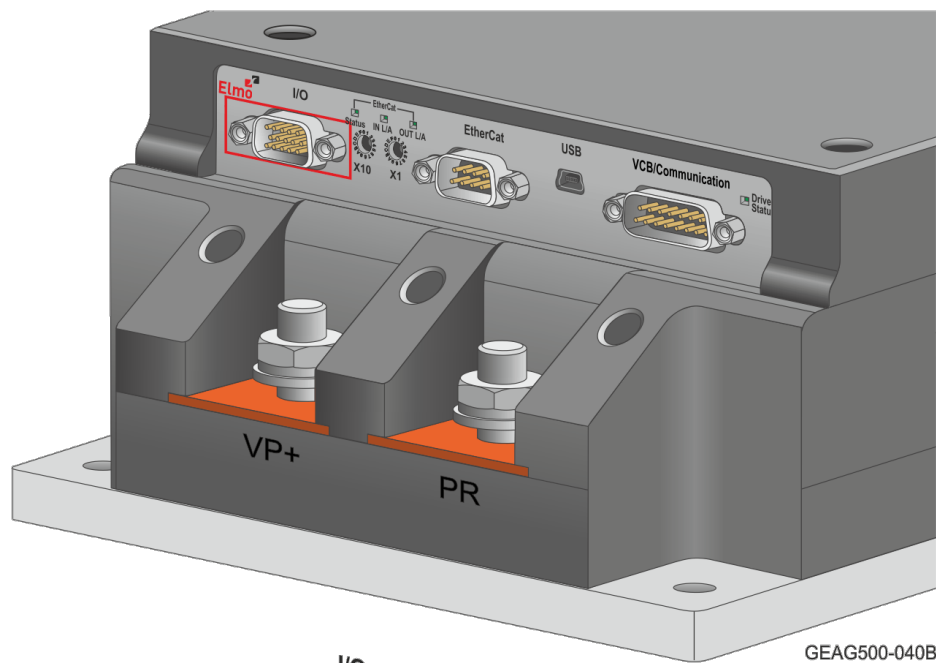

15-Pin High Density D-Type Male Connector

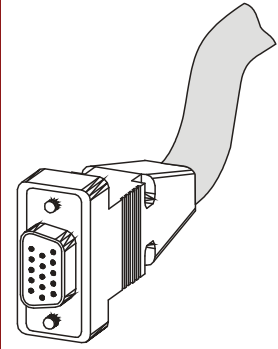

15-Pin High Density D-Type Female Connector

Table 6: I/O Connector Pin Assignments



6.8.1 Digital Input and Output TTL Source Mode

The following figure describes the connections at the I/O Port for the Digital Input and Output TTL Source Mode.

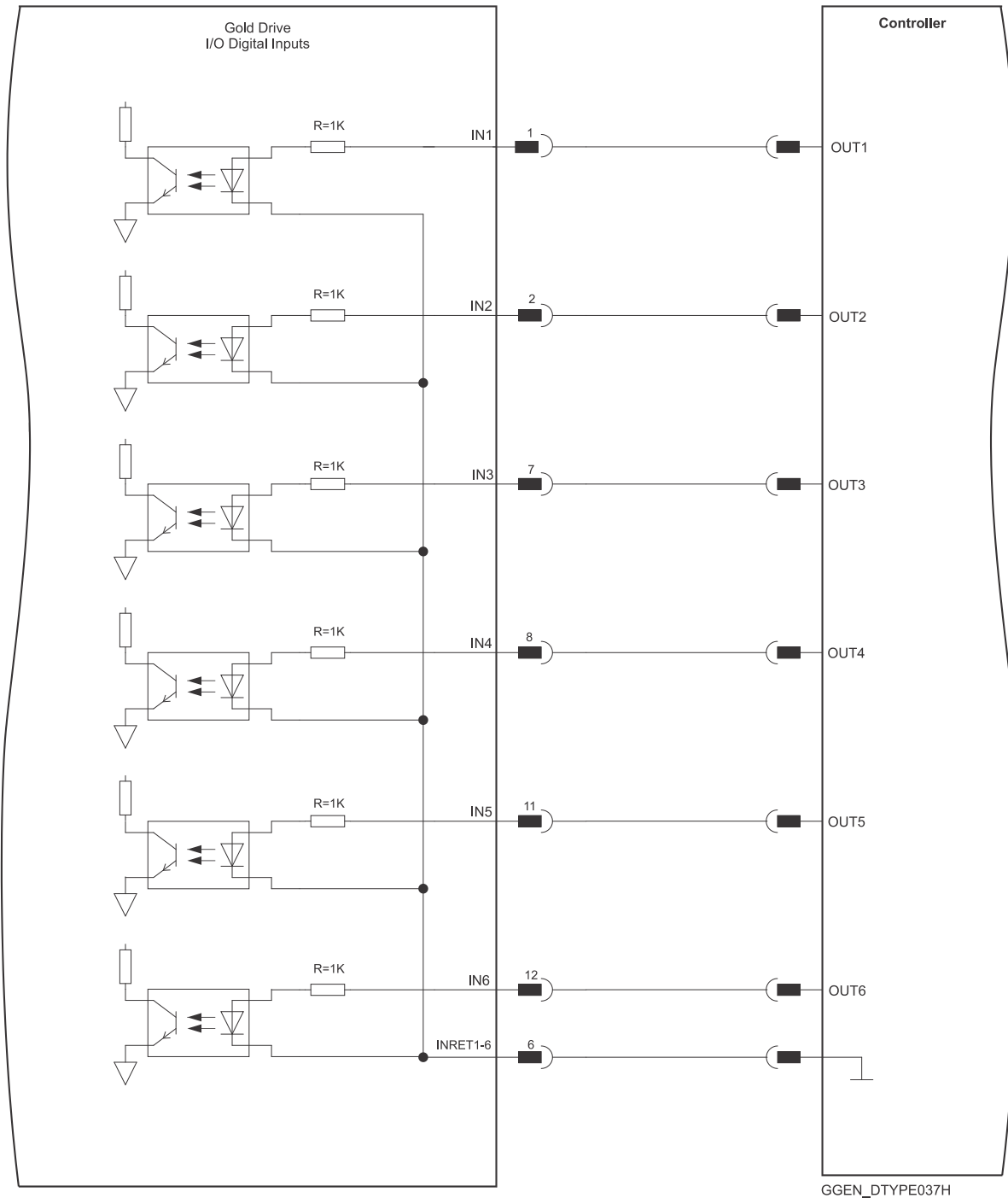

Figure 26: Digital Input TTL Source Mode D-Type Connection Diagram

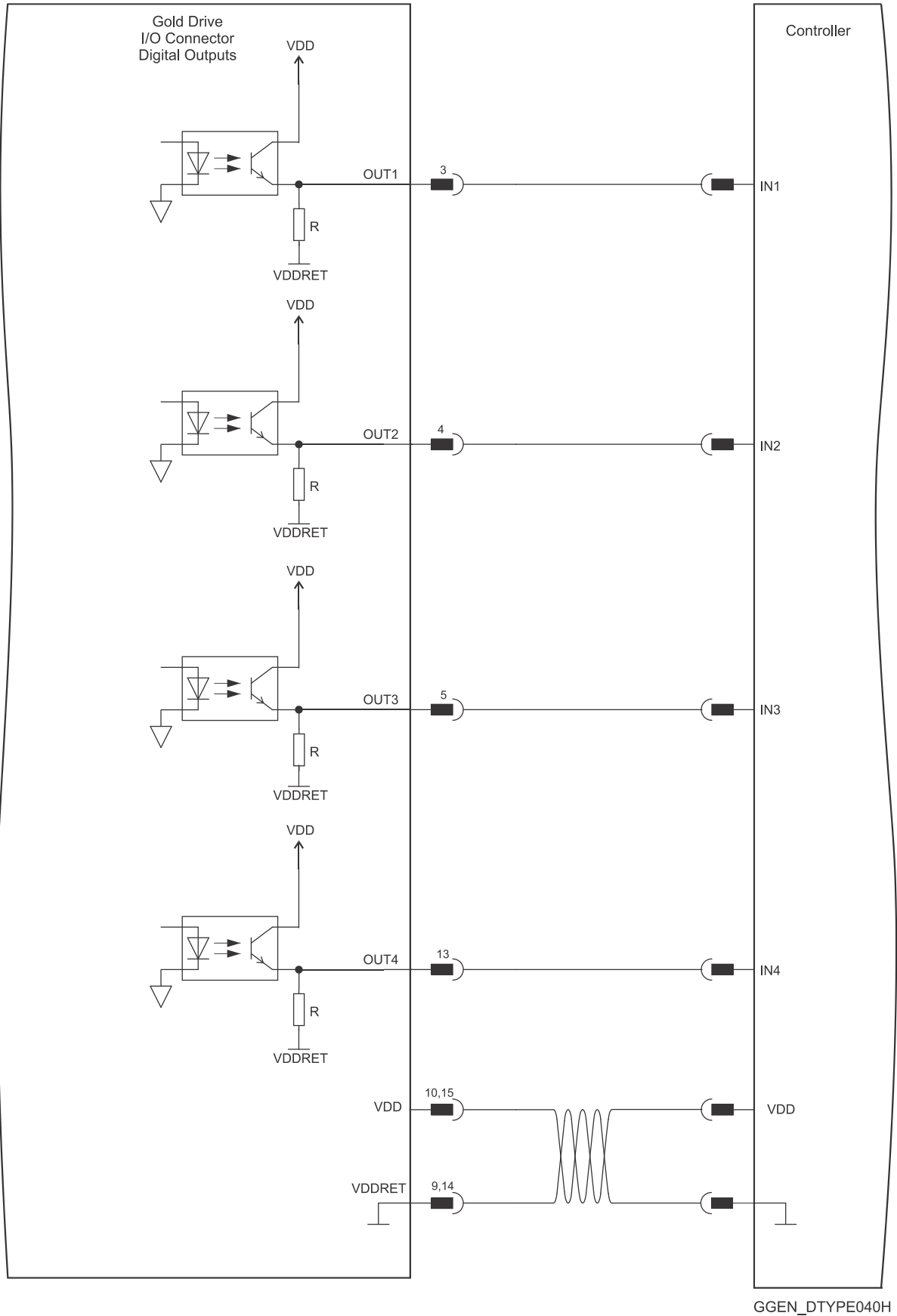

Figure 27: Digital Output D-Type Connection Diagram – TTL Source Option



6.8.2 Digital Input and Output PLC Source Mode

The following figure describes the connections at the I/O Port for the Digital Input and Output PLC Source Mode.

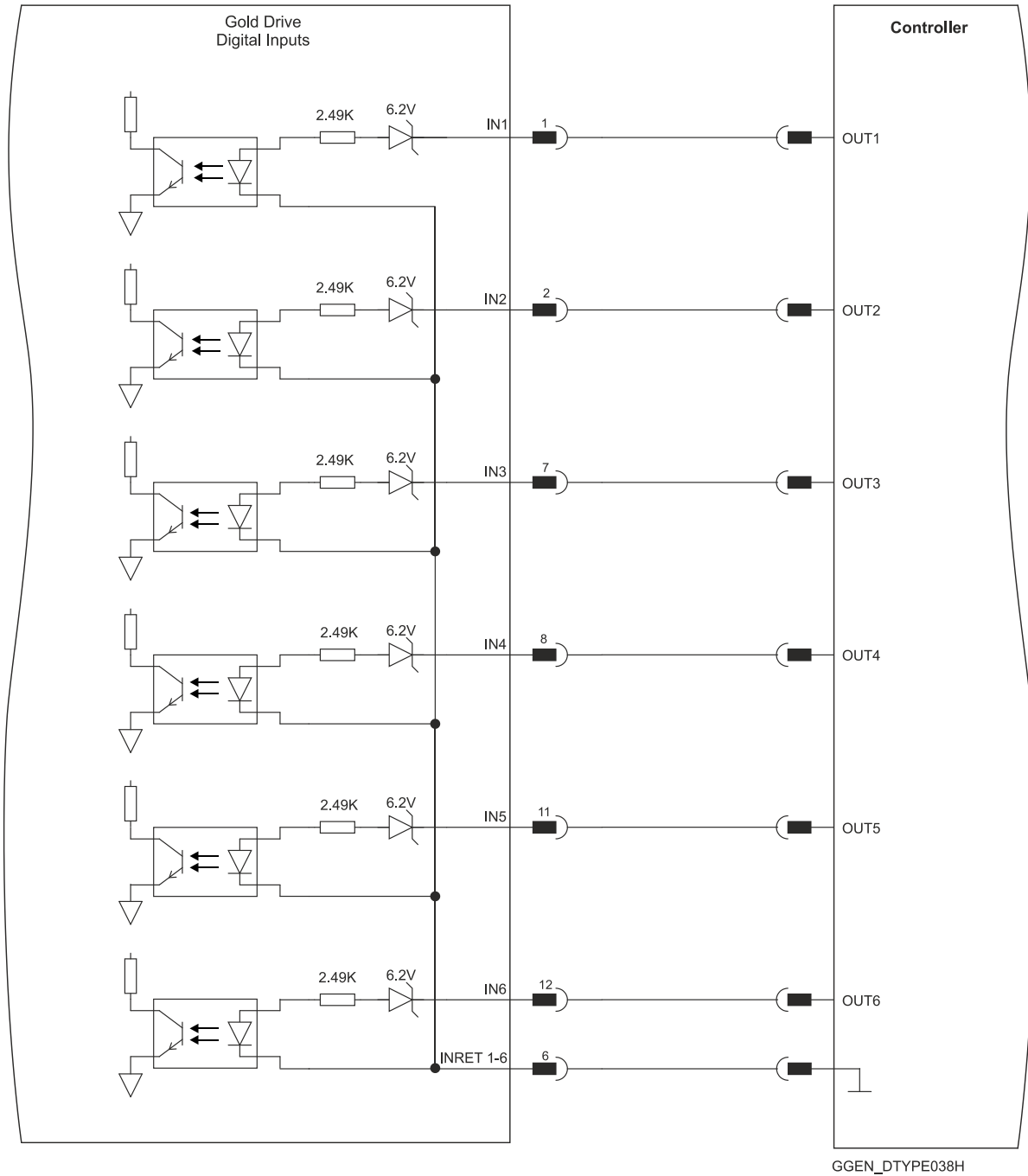

Figure 28: Digital Input D-Type Connection Diagram – Source PLC Option

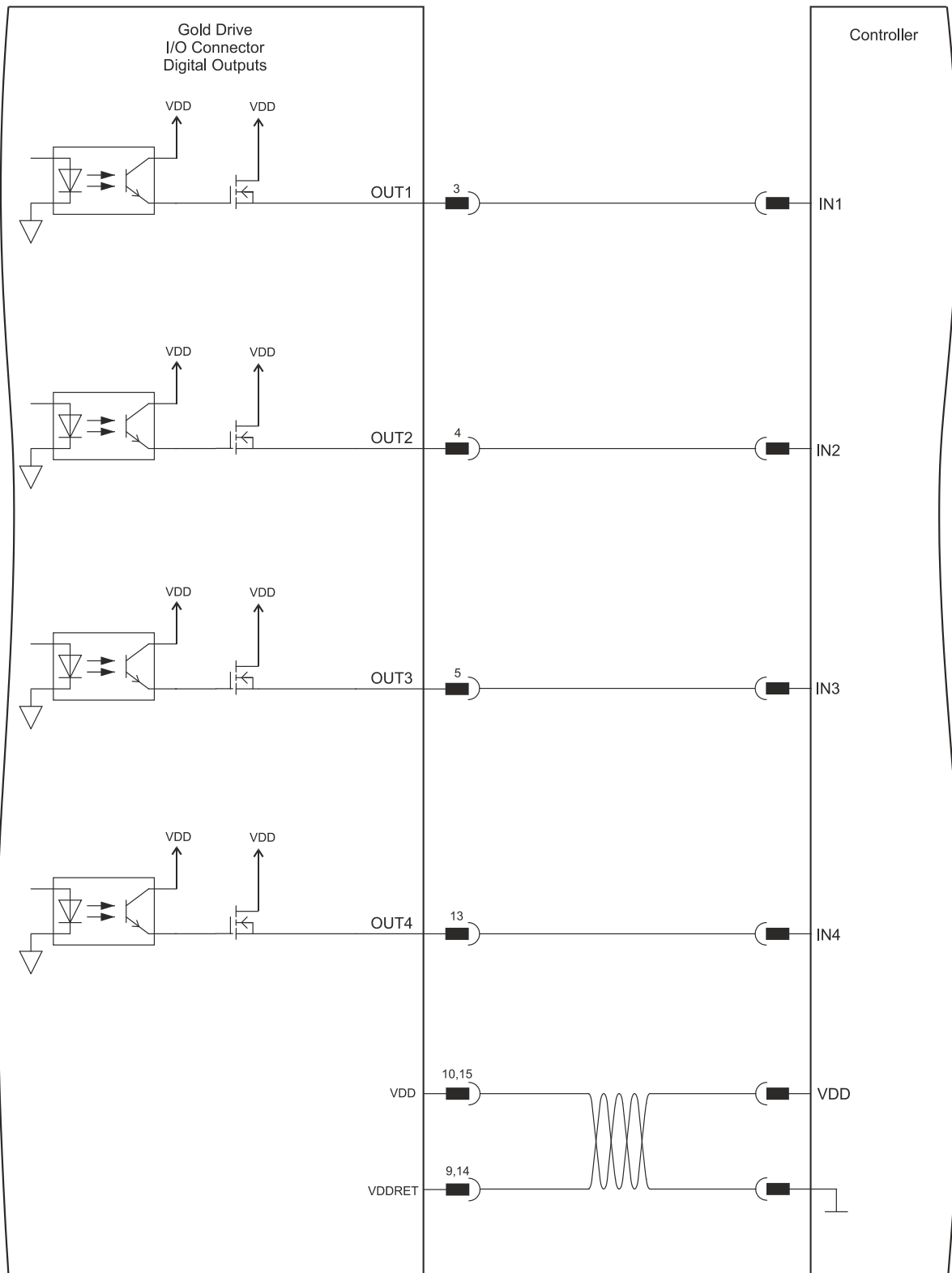

Figure 29: Digital Output D-Type Connection Diagram – Source PLC Option



6.8.3 Digital Input and Output PLC Sink Mode

The following figure describes the connections at the I/O Port for the Digital Input and Output PLC Sink Mode.

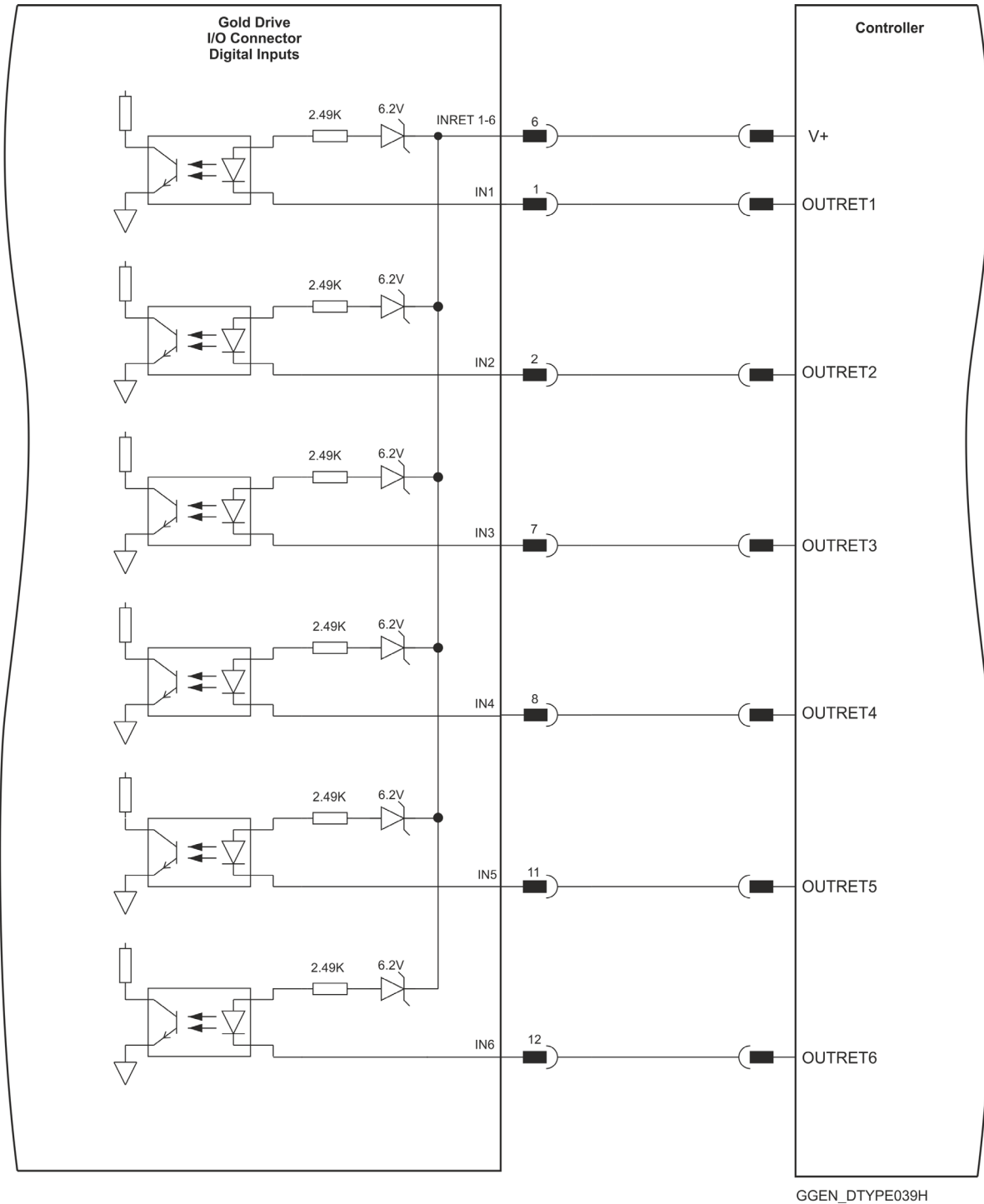

Figure 30: Digital Input PLC Sink Mode – PLC voltage level D-Type Connection Diagram

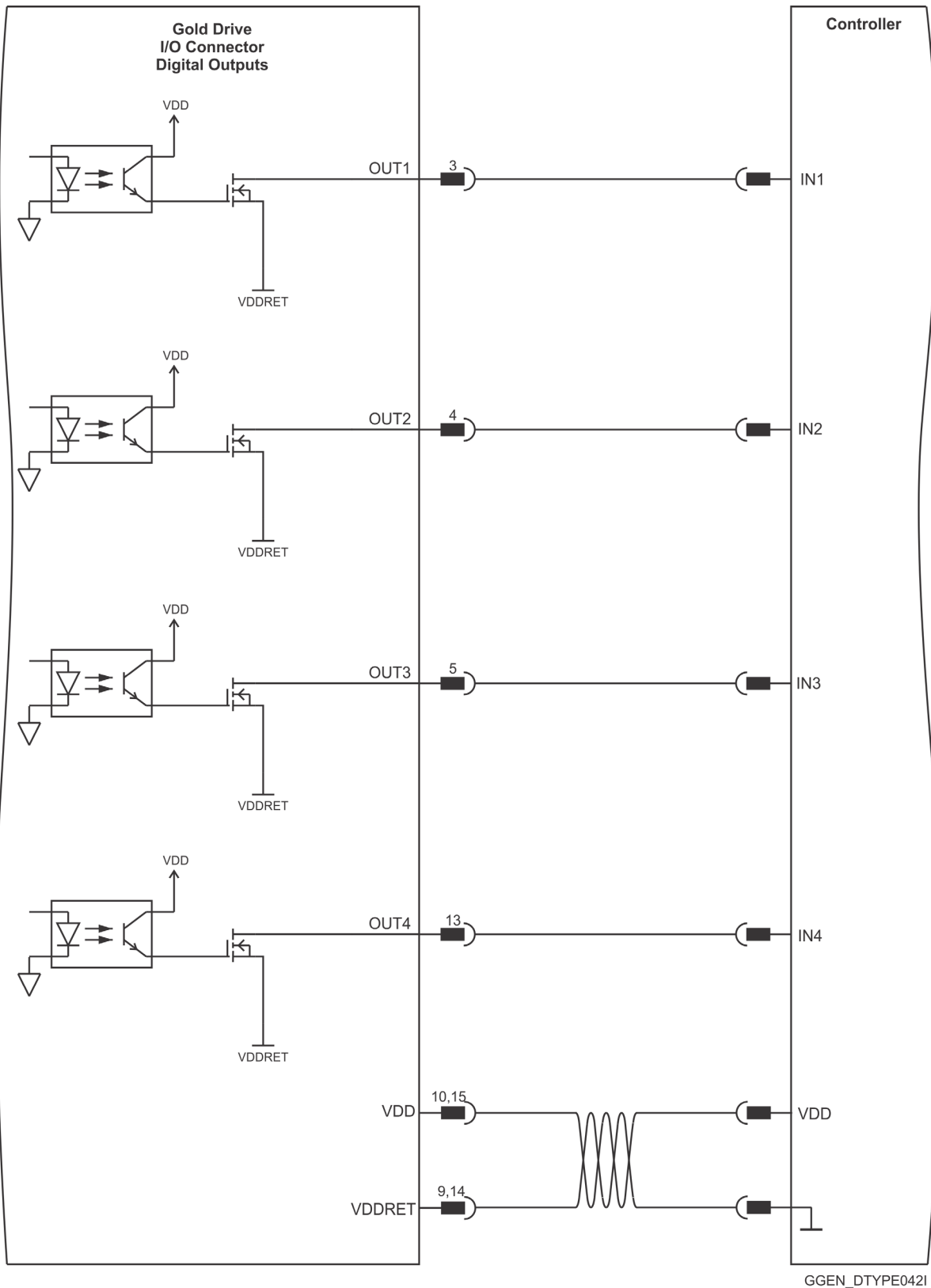

Figure 31: Digital Output as PLC Sink Configuration D-Type Connection Diagram



6.9 USB 2.0 Option 1

See Section 12.1 in the in the MAN-G-Panel Mounted Drives Hardware manual for full details.

Note: The USB connection can be either from the front mini USB connector or from the VCB/Communication D-Type connector.

Note: DO NOT connect the USB communication from the front mini USB and the VCB/Communication D-Type connector simultaneously.

Pin on USB	Signal	Function
1	USB VBUS	USB VBUS 5V
2	USBD-	USB _N line
3	USBD+	USB _P line
5	USB COMRET	USB communication return

Pin Positions

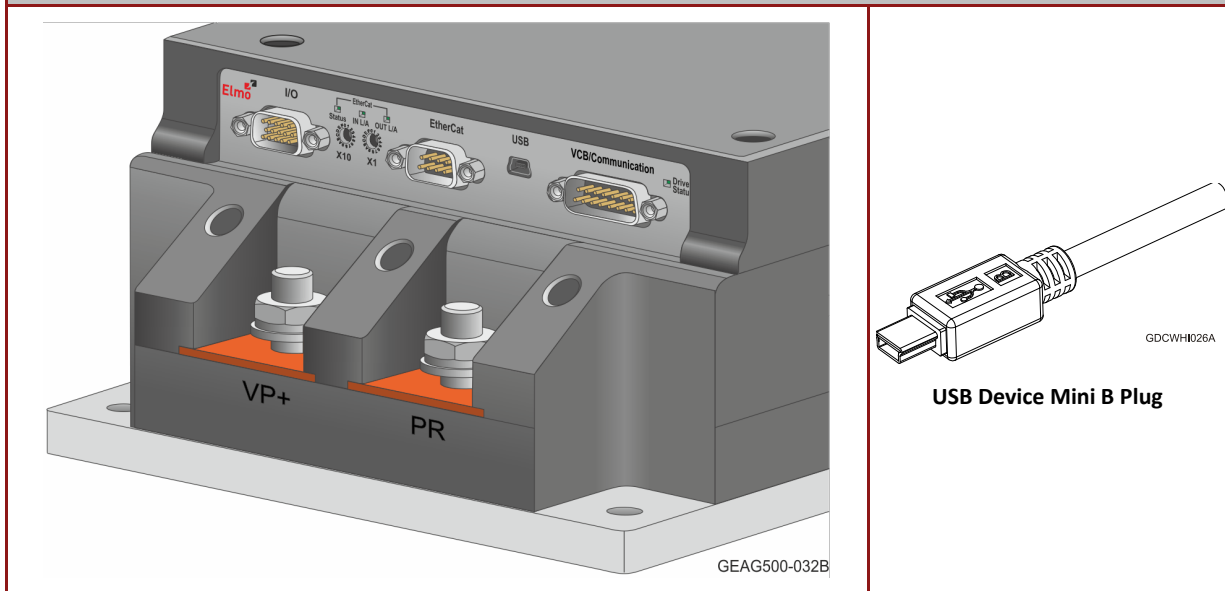
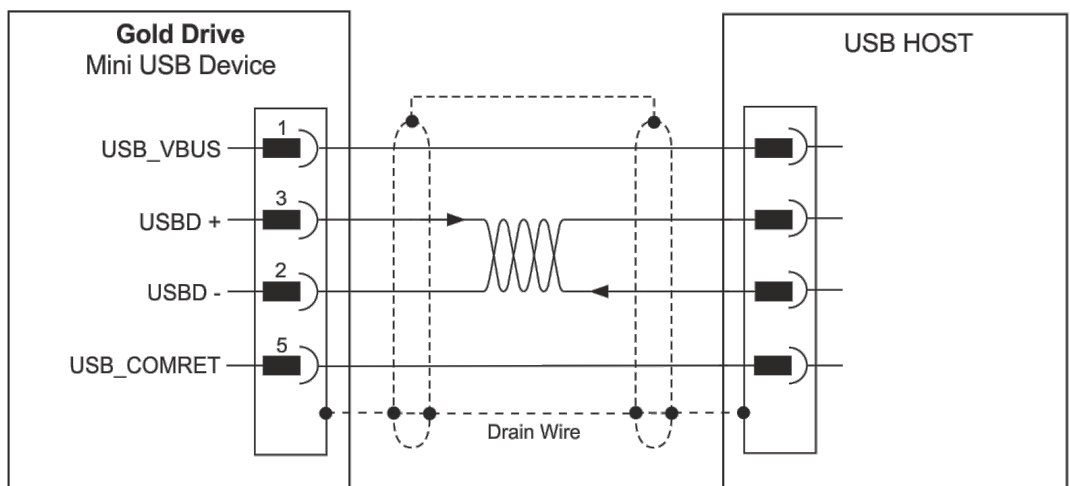

Table 7: USB 2.0 Pin Assignments



GGEN_DTYP044G

Figure 32: USB Network Diagram



6.10 VCB/Communication Connector

See Section 6.2.2 for full details.

Note: The USB connection can be either from the front mini USB connector or from the VCB/Communication D-Type connector.

DO NOT connect the USB communication from the front mini USB and the VCB/Communication D-Type connector simultaneously.

Pin	Signal	Function
2	USB_VBUS	USB VBUS 5V
1	USB D-	USB _N line
9	USB D+	USB _P line
10	USB COMRET	USB Common Return
3	COMRET	Common Return (connected to the drain wire of cable)
11	COMRET	Common Return
4	RS-232_RX/RS-422_RX+	RS-232 Receive/RS-422 Receive+
5	RS-422_TX-	RS-422 Transmit-
13	RS-422_TX+	RS-422 Transmit+
12	RS-232_TX/RS-422_RX-	RS-232 Transmit/RS-422 Receive-
15	Not in use	
7	Not in use	
14	VCB Supply Input Positive	DC Power
6	COMRET	DC Power
8	VCB Supply Shield	Drain wire cable



Pin Positions

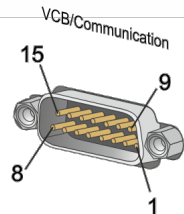
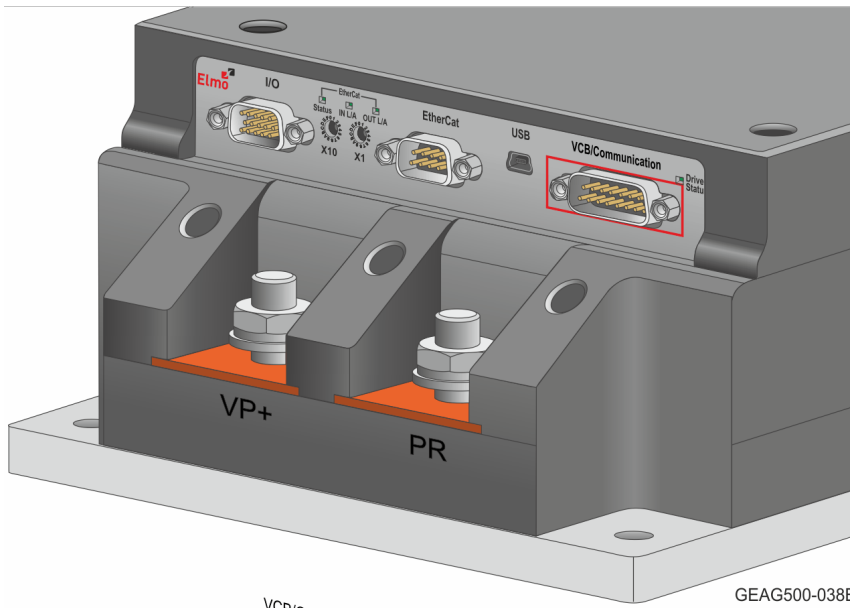

15-Pin D-Type Male Connector

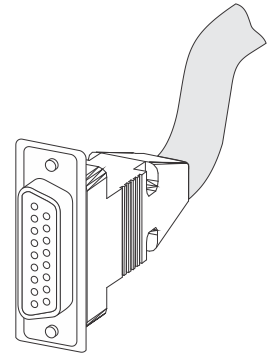

GEAGHV022A

15-pin D-Type Female Connector

6.10.1 USB 2.0 Option 2

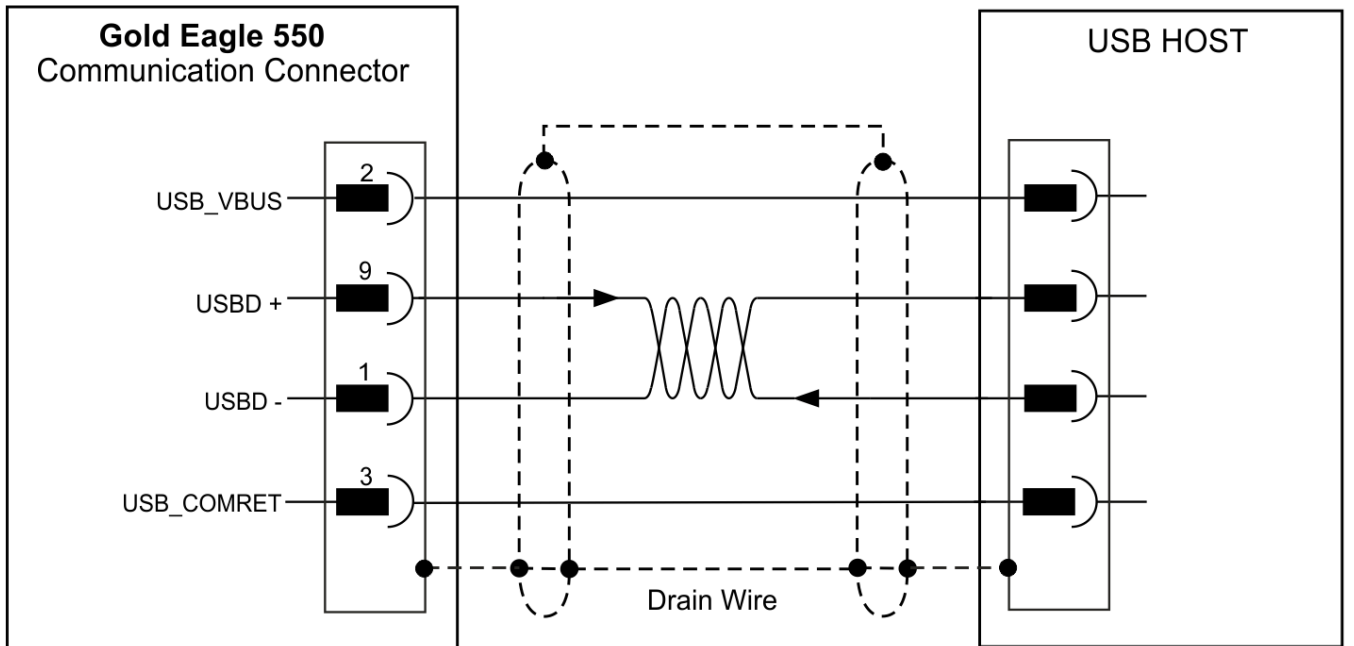

GEAG550-052A

Figure 33: USB Network Diagram



6.10.2 RS-232

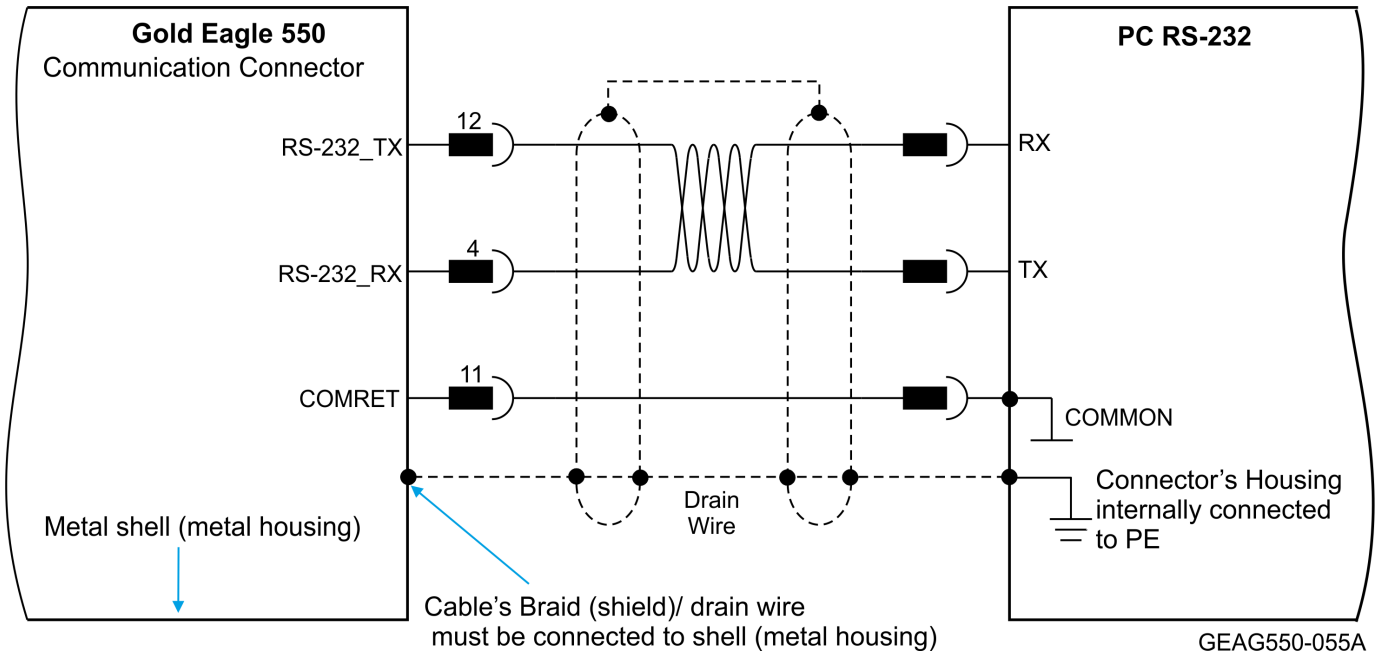

Figure 34: RS-232 D-Type Connection Diagram Example

6.10.3 RS-422 (Differential RS-232)

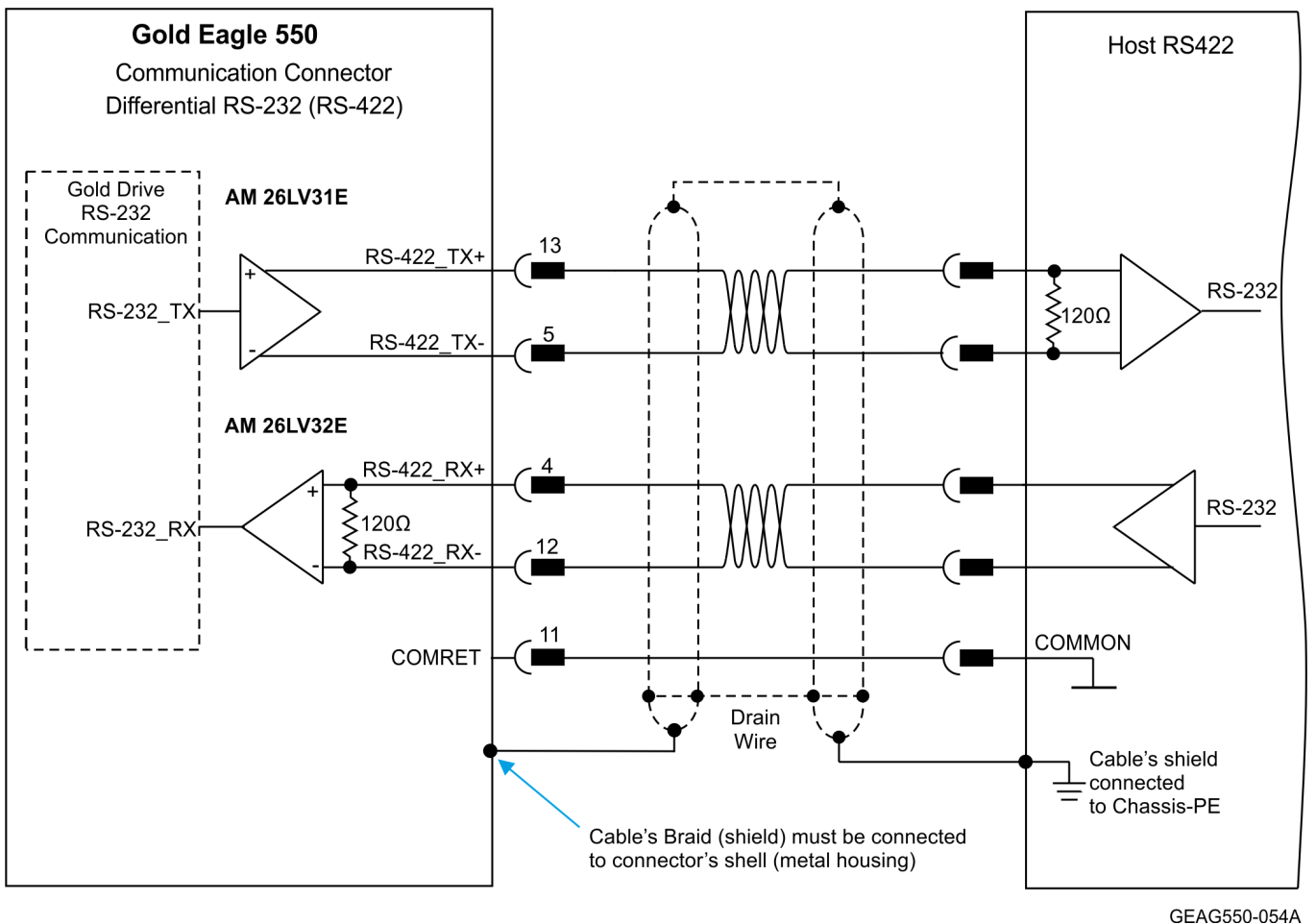

Figure 35: Differential RS-232 D-Type Connection Diagram Example



6.11 EtherCAT Communications Version

The Gold Eagle 550/650 supports EtherCAT fieldbus industrial network protocol.

Fieldbus Type	Product Number
EtherCAT + RS-232	G-EAGR550/100EXXX
	G-EAGR650/80EXXX
EtherCAT with switches	G-EAGR550/100FXXX
	G-EAGR650/80FXXX
EtherCAT + Differential RS-232 (RS-422)	G-EAGR550/100GXXX
	G-EAGR650/80GXXX

6.11.1 EtherCAT/Ethernet Pinouts

See Section 6.8.2 in the manual: MAN-G-Drive Hardware for the electrical diagram.

Pin	Signal	Function
1	EtherCAT_IN_TX+/Ethernet_TX+	EtherCAT in transmit+/Ethernet transmit +
2	EtherCAT_IN_RX+/Ethernet_RX+	EtherCAT in receive+/Ethernet receive+
3	EtherCAT_OUT_TX+	EtherCAT out transmit+
4	EtherCAT_OUT_RX+	EtherCAT out receive+
5	EtherCAT Shield	Drain wire cable
6	EtherCAT_IN_TX-/Ethernet_TX-	EtherCAT in transmit-/Ethernet transmit-
7	EtherCAT_IN_RX-/Ethernet_RX-	EtherCAT in receive-/Ethernet receive-
8	EtherCAT_OUT_TX-	EtherCAT out transmit-
9	EtherCAT_OUT_RX-	EtherCAT out receive-



Pin Positions

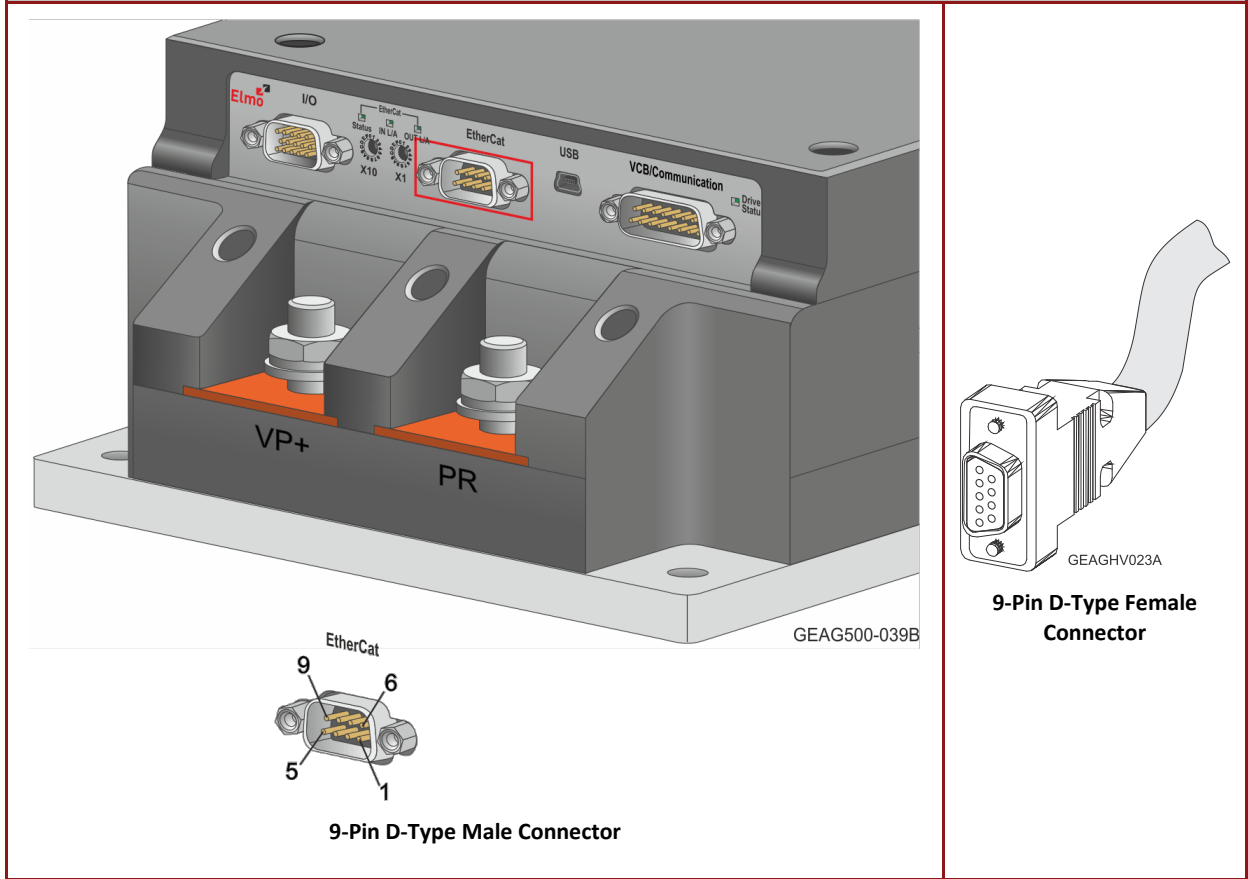

Table 8: EtherCAT Connector Pin Assignments

6.11.2 EtherCAT Wiring

Figure 36 describes the wiring diagram for the EtherCAT connections.

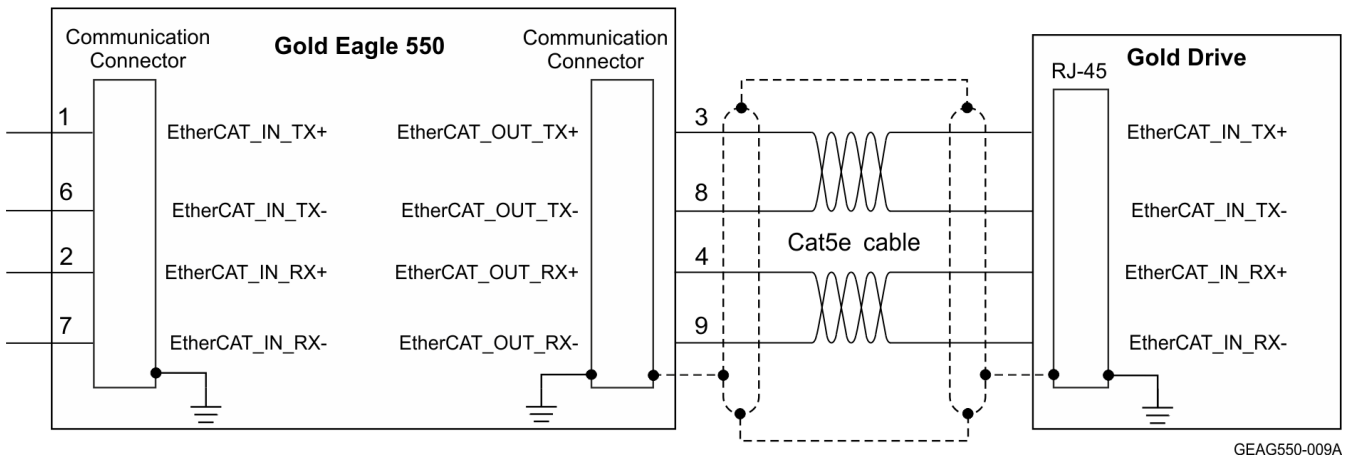

Figure 36: EtherCAT RJ-45 Connections



6.11.3 EtherCAT and Drive Status Indicator LEDs

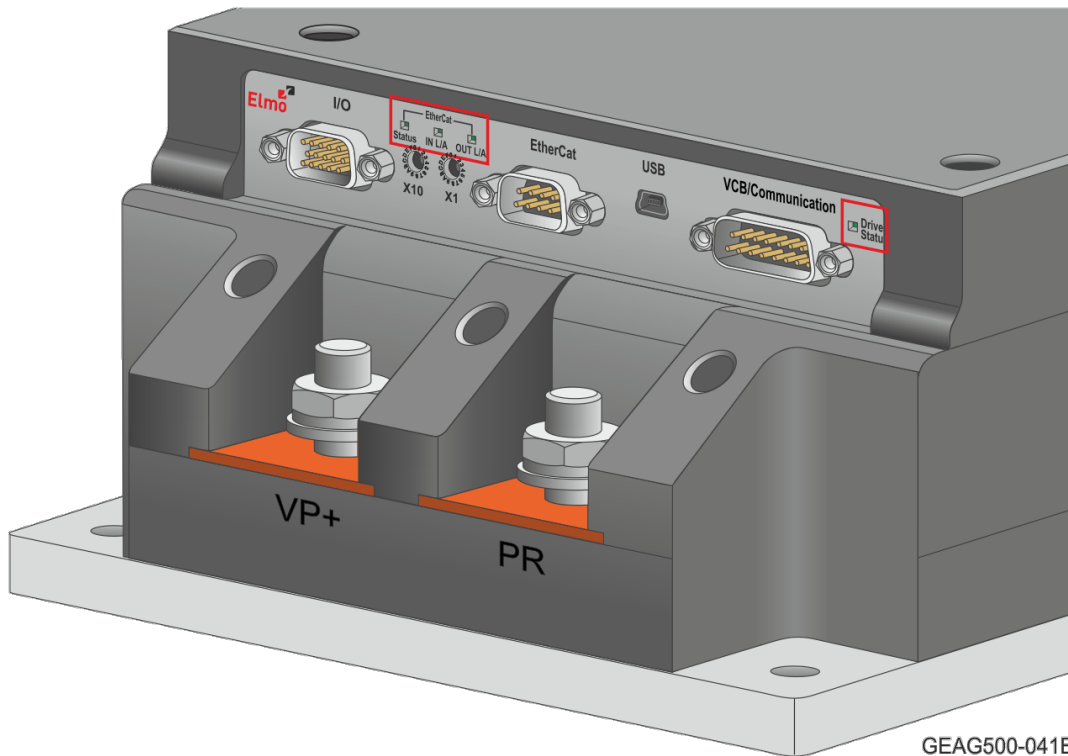

Figure 37: EtherCAT and Drive Status Indicator LEDs on Gold Eagle 550/650

The Gold Eagle 550/650 is equipped with several light-emitting diode (LED) indicators:

- Drive Status
- EtherCAT indicators

The **Drive Status Indicator** red/green dual LED is used for immediate indication of the Initiation and Working states.

The red/green dual LED is used for immediate indication of the following states:

- **Initiation state:** In this state the LED indicates whether the drive is in the boot state (blinking red) or in the operational state (steady red).
- **Working state:** In this state the LED indicates whether the drive is in an amplifier failure state (red) or is ready to enable the motor (green).

The **EtherCAT status indicator** is a red/green dual LED. It combines run indication (when it is green) and error indication (when it is red) of the EtherCAT device.

The Gold Eagle 550/650 can serve as an EtherCAT slave device. For this purpose it has a D-Type connector, which is designated as EtherCAT In and EtherCAT Out.

The green LED is the link/activity indicator. It shows the state of the applicable physical link and the activity on that link. The amber LED is the speed indicator. It shows the speed of the connection on the Ethernet line. Refer to the section 12.2.1.2 in the document; MAN-G-Panel Mounted Drives Hardware manual.



6.11.4 EtherCAT Rotary Switches

Note: This option is only for the **G-EAGR550/100FXXX**, **G-EAGR650/80FXXX** types.

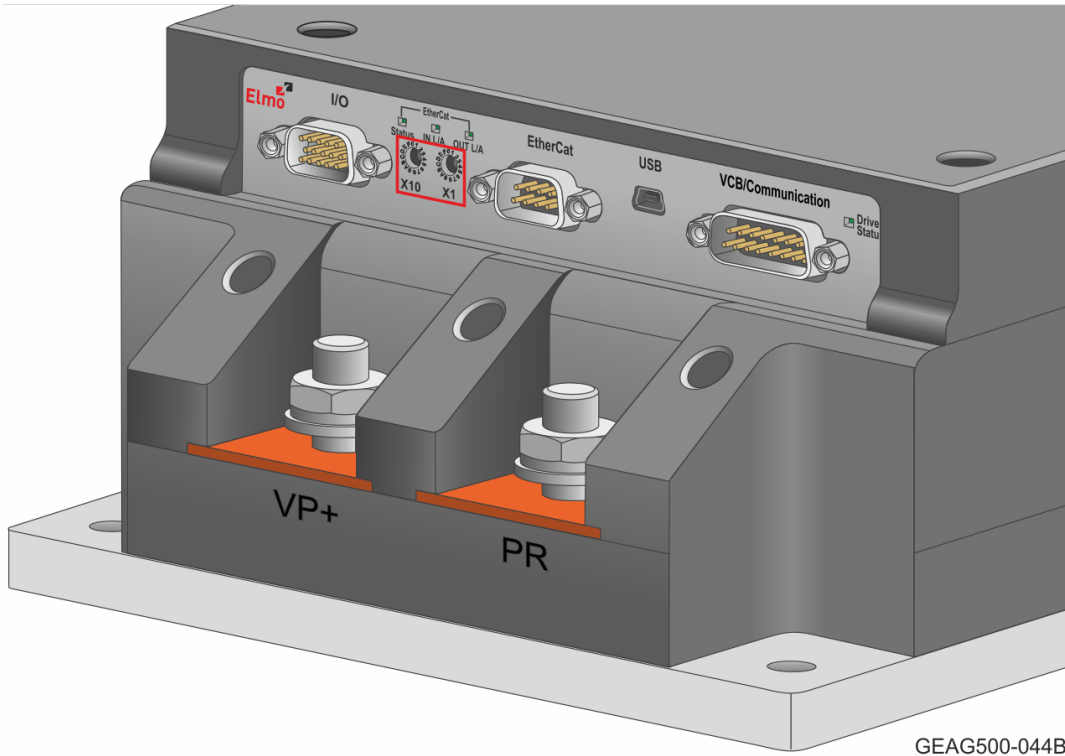

Figure 38: Position of EtherCAT Address Switches on Gold Eagle 550/650

The positions of the switches on the drive are shown in Figure 38. Use a screwdriver to set the low and high bytes values of the drive EtherCAT address. This address is only retrieved after power-up.



6.12 CAN Communications Version

Fieldbus communications are industrial network protocols for real-time distributed control that allows connection of servo drives. The Gold Eagle 550/650 supports the following CAN fieldbus type industrial network protocol:

Fieldbus Type	Product Number
CAN + RS-232	G-EAGR550/100SXXX
	G-EAGR650/80SXXX
CAN + Differential RS-232 (RS-422)	G-EAGR550/100TXXX
	G-EAGR650/80TXXX

See Section 6.8.4 in the manual: MAN-G-Drive Hardware for the electrical diagram.

Pin on CAN	Signal	Function
1, 3	CAN_H	CAN_H bus line (dominant high)
6, 8	CAN_L	CAN_L bus line (dominant low)
7, 9	CAN_RET	CAN Return
5	CAN_SHLD	Drain wire cable

Pin Positions

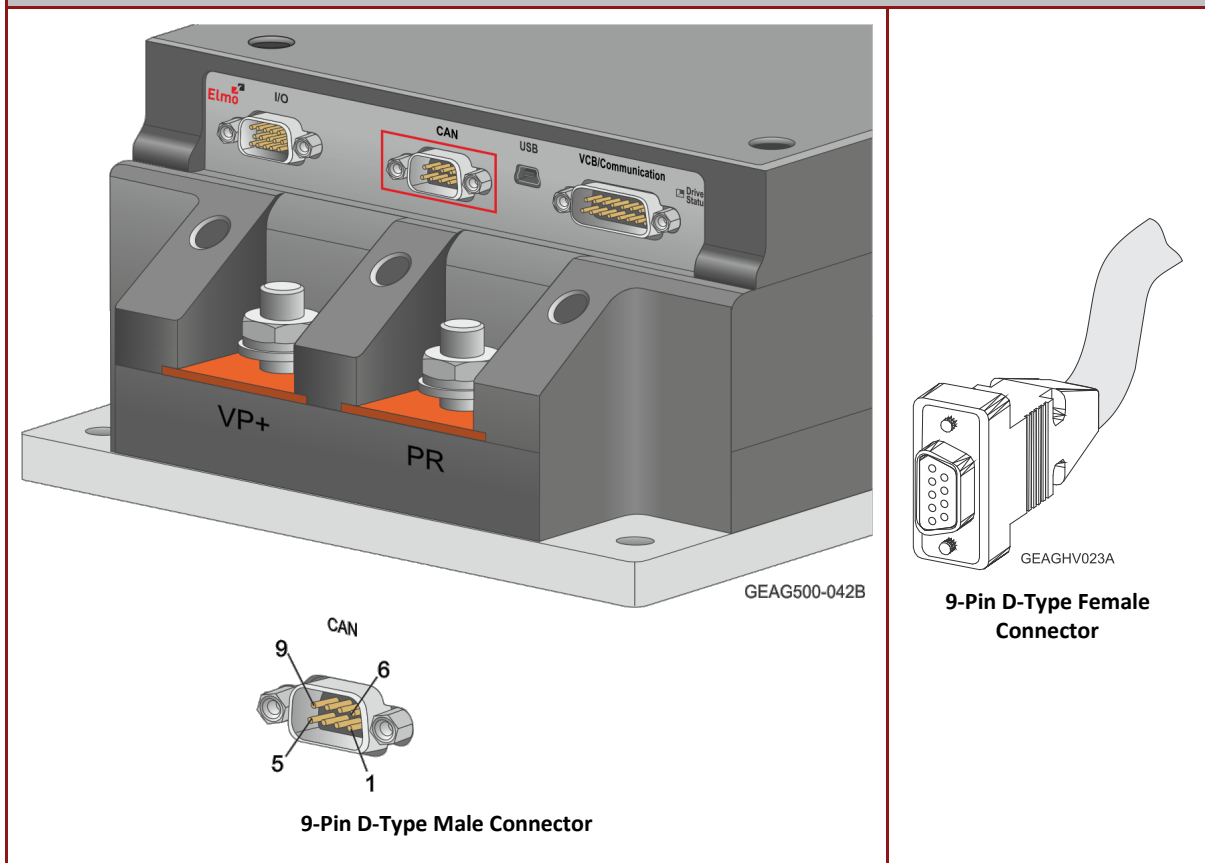
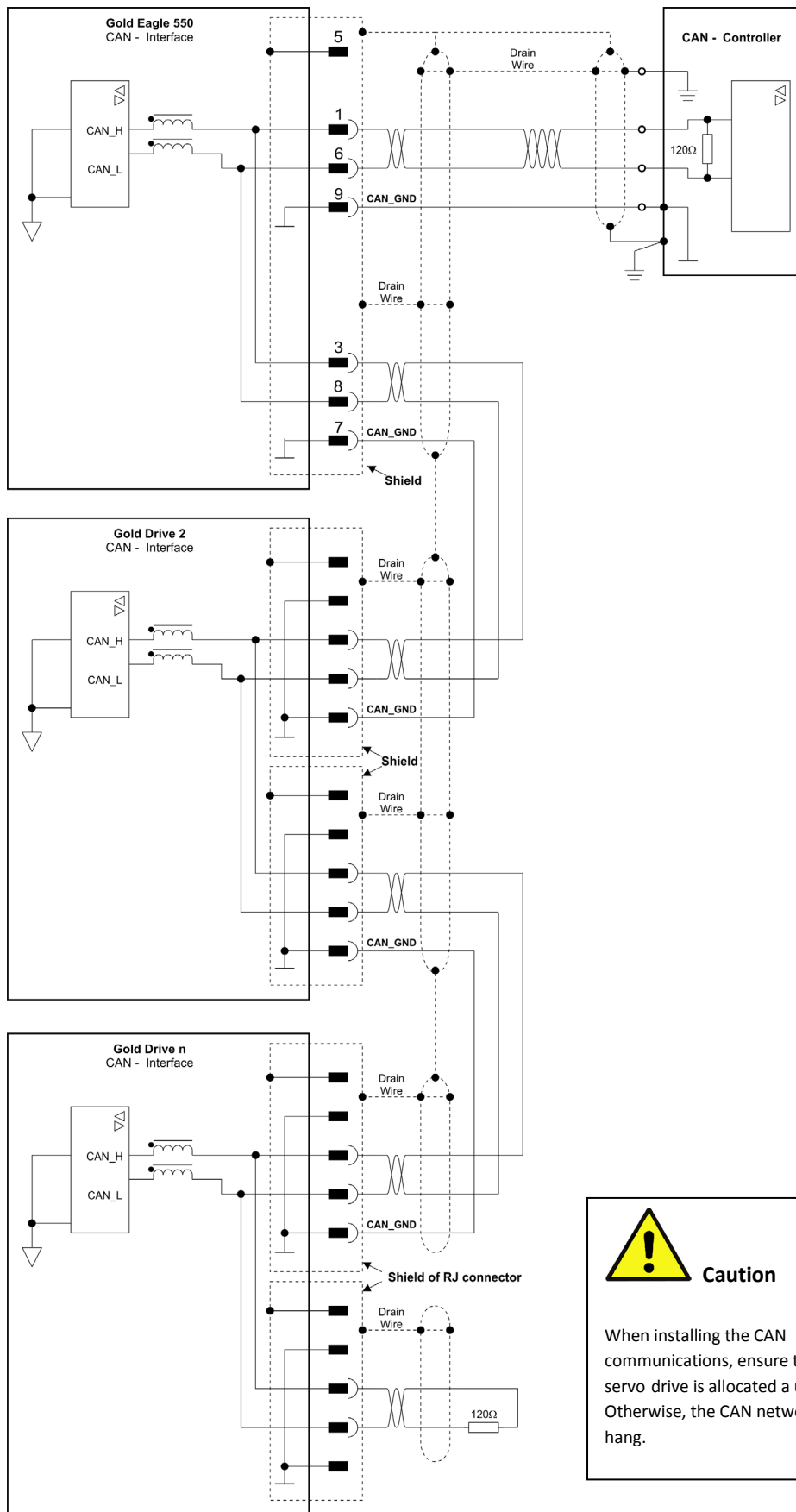

Table 9: CAN In/Out Connector Pin Assignments



6.12.1 CAN Wiring

Figure 39 describes the CAN wiring diagram below.



GEAG550-053A

Figure 39: Gold Eagle 550/650 Connection Diagram – CAN



Caution

When installing the CAN communications, ensure that each servo drive is allocated a unique ID. Otherwise, the CAN network may hang.



6.12.2 CAN Indicator

There is one indicator LED; the **Drive Status**. For details of the Drive Status, refer to Section 6.2 in the MAN-G-Panel Based Drive Hardware manual.

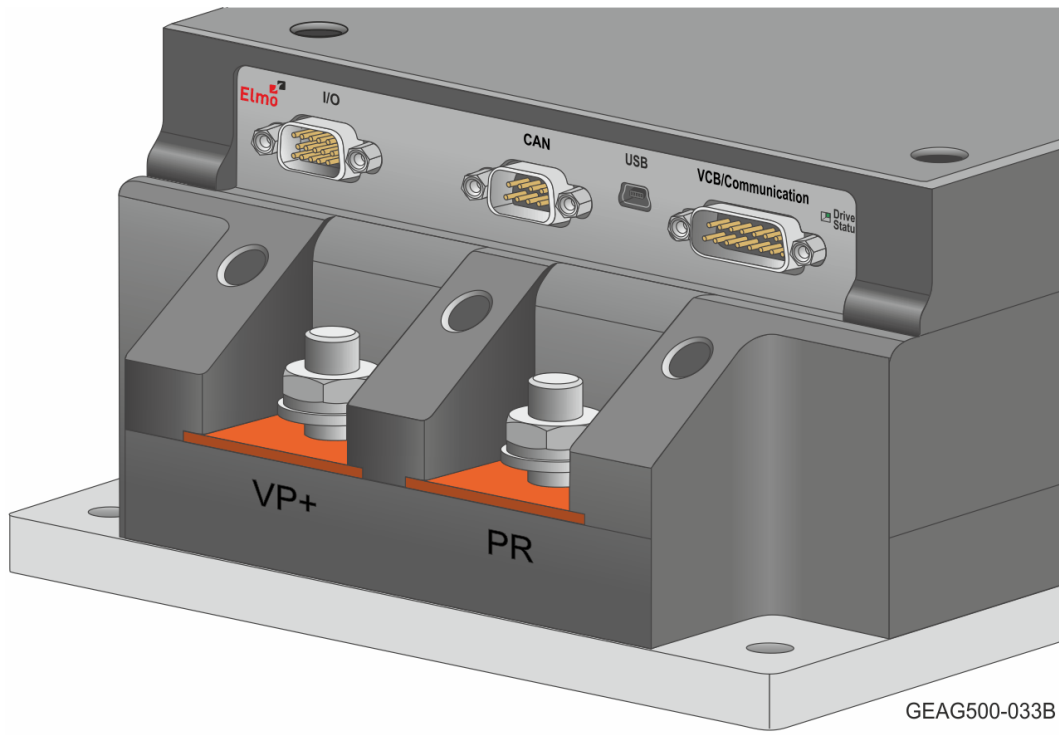

Figure 40: Drive Status Indicator LEDs on Gold Eagle 550/650 – CAN Version

The **Drive Status Indicator** red/green dual LED is used for immediate indication of the Initiation and Working states.

The red/green dual LED is used for immediate indication of the following states:

- **Initiation state:** In this state the LED indicates whether the drive is in the boot state (blinking red) or in the operational state (steady red).
- **Working state:** In this state the LED indicates whether the drive is in an amplifier failure state (red) or is ready to enable the motor (green).



7. Heat Dissipation

For full power output capability the Gold Eagle 550/650 is designed to be mounted on an external heat-sink. It is highly recommended that the “Wall” on which the Gold Eagle 550/650 is mounted will have heat dissipation capabilities. The Gold Eagle 550/650 at “free air convection” (without an additional heat-sink) can dissipate around 20W - 30 W not exceeding 80 °C on the heat sink.

When “Free Air Convection” is sufficient for the application it is recommended to leave approximately 10 mm of space between the Gold Eagle 550/650's heat sink and any other assembly.

7.1 Gold Eagle 550/650 Thermal Data

- Free air convection thermal resistance (θ): Approximately 12- 18°C/W.
- Thermal time constant: Approximately 40 minutes/ 2400 seconds (thermal time constant means that the Gold Eagle 550/650 will reach 2/3 of its final temperature after 40 minutes).
- Self-heat dissipation capability (no external heat sink): 20 W -30W for 40°C/W temperature rise.
- Shut-off temperature: 86 to 88°C.
- The thermal resistance when connecting to an external heat sink using a thermal conductive compound/foil. By proper smearing of the surface a significant improvement of the thermal resistance is achieved: $\approx 0.018^\circ\text{C/W}$.
- When attaching to an external heat-sink, it is recommended to use $\sqrt{R_z}10$ surface treatment and thermal foil or smearing thermal compound.



7.2 Heat Dissipation Data

Heat Dissipation is shown graphically below:

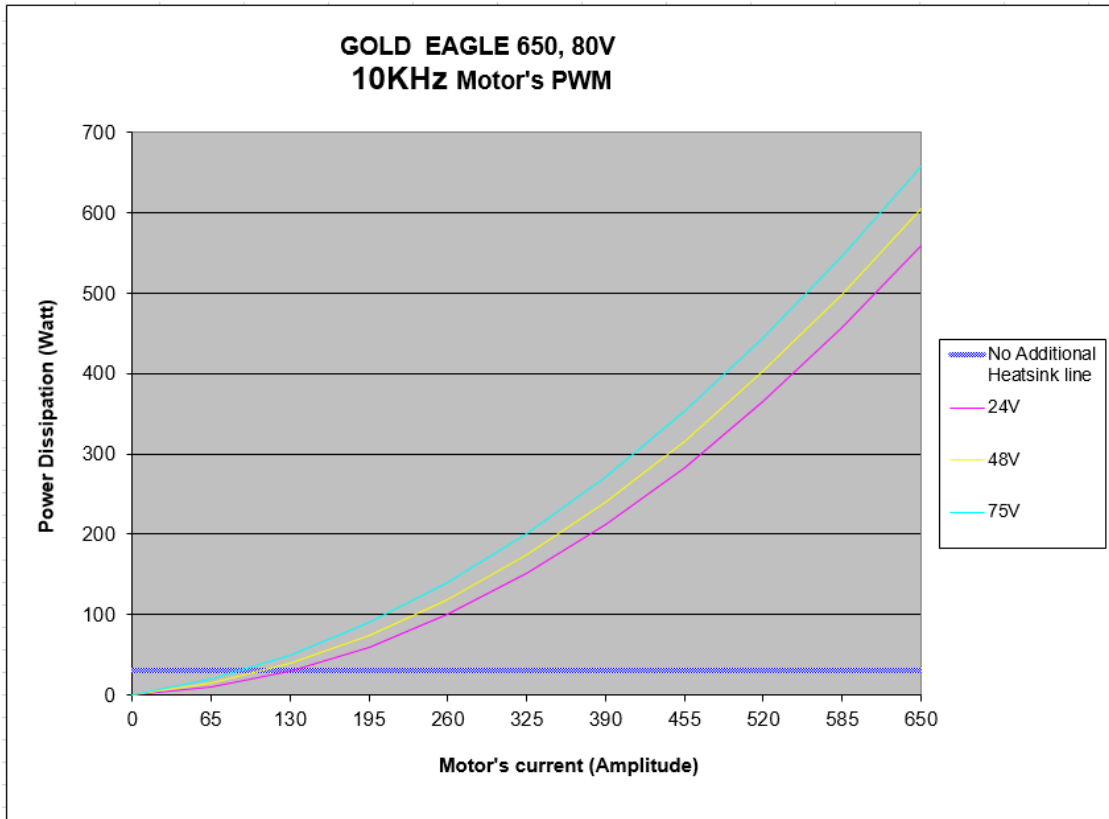

Figure 41: Dissipation versus Current Graph for 80 VDC @ 10KHz PWM

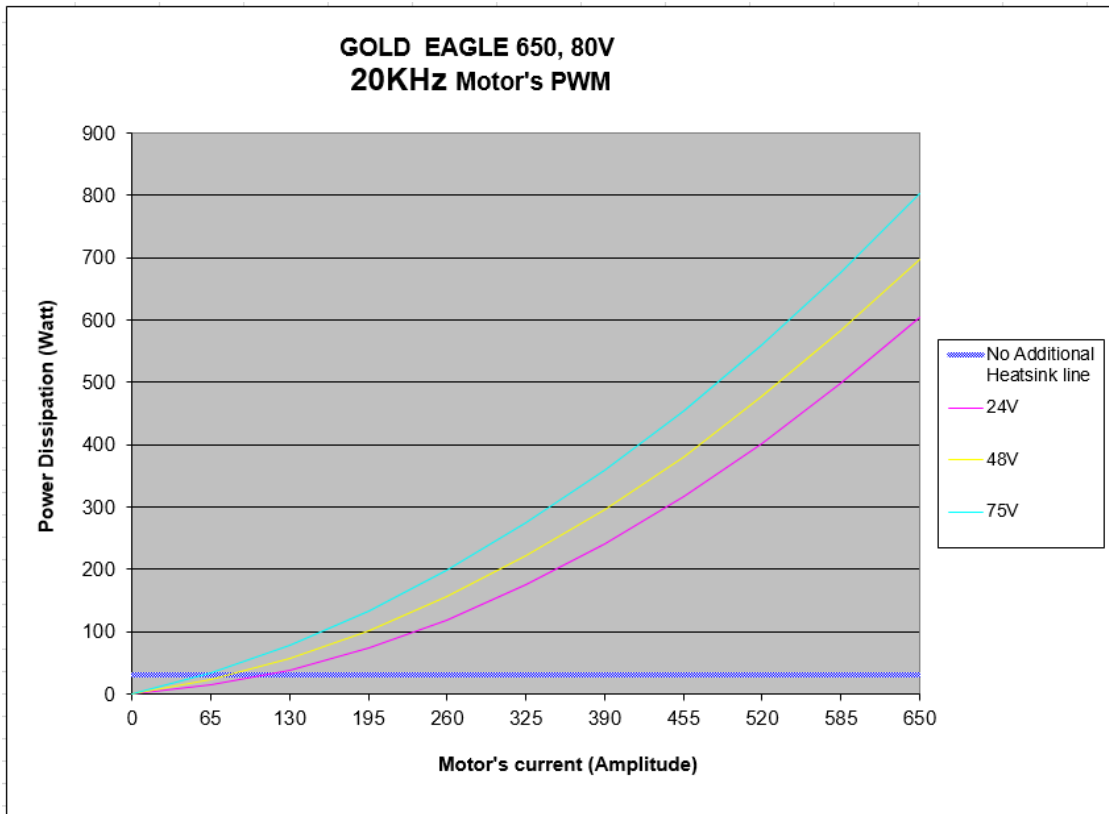

Figure 42: Dissipation versus Current Graph for 80 VDC @ 20KHz PWM

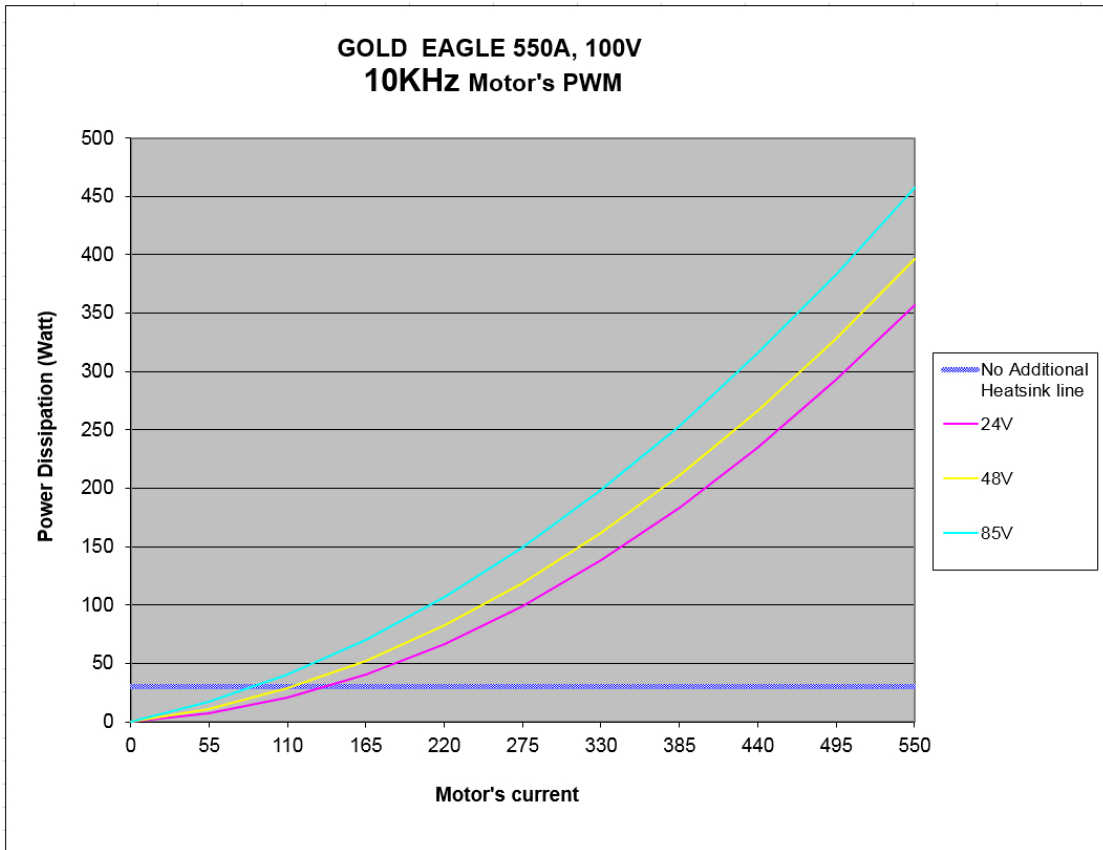

Figure 43: Dissipation versus Current Graph for 100 VDC @ 10KHz PWM

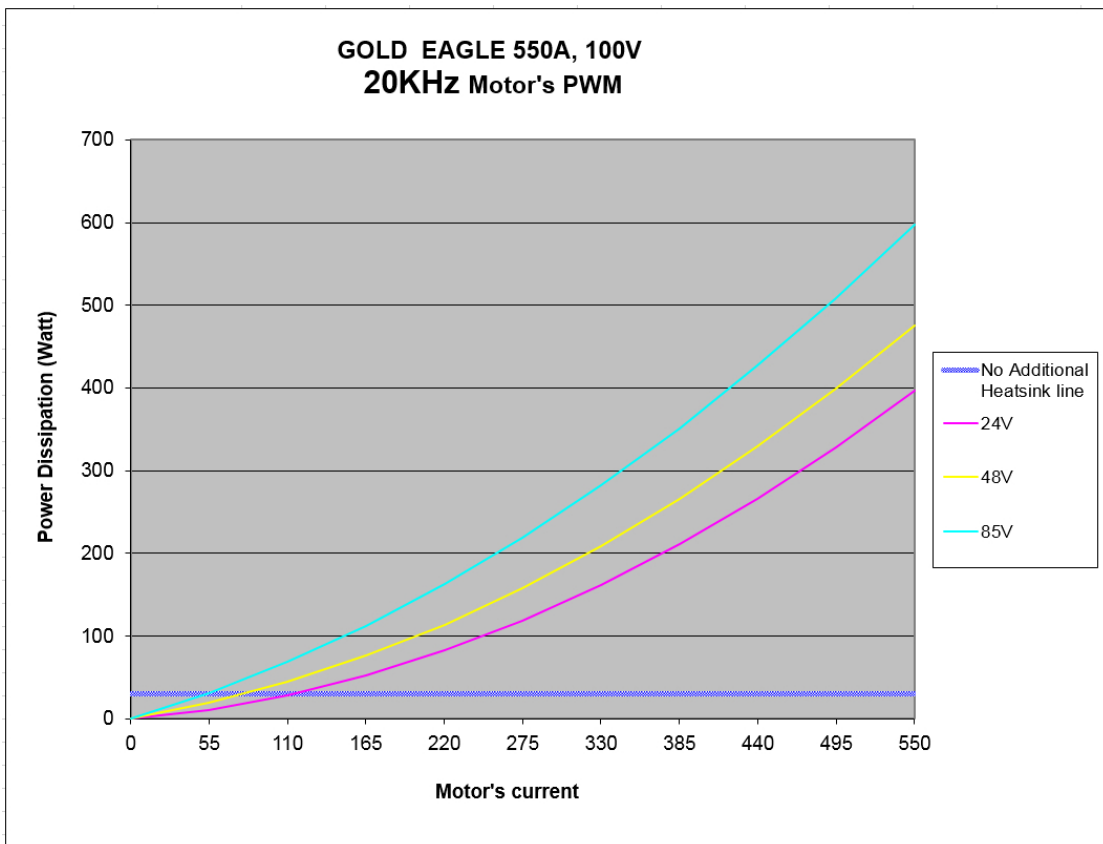

Figure 44: Dissipation versus Current Graph for 100 VDC @ 20KHz PWM



7.3 How to Use the Charts

The charts above are based upon theoretical worst-case conditions. Actual test results show 30% to 50% better power dissipation.

To determine if your application needs a heat sink:

1. Allow maximum heat sink temperature to be 80 °C or less (shunt down is 6 °C to 8 °C higher).
2. Determine the ambient operating temperature of the Gold Eagle 550/650 as $\leq 70^{\circ}\text{C}$.
3. Calculate the allowable temperature increase according to the following example: For an ambient temperature of 70 °C, $\Delta T = 80$ to $70^{\circ}\text{C} = 10^{\circ}\text{C}$
4. Use the chart to find the actual dissipation power of the drive. Follow the voltage curve to the desired output current and then find the dissipated power.

7.4 Thermal Operating Envelope

The Gold Eagle 550/650 drive has a built in Safe Operating Area Thermal Limit Envelope, as defined in the following "Current vs. Temperature" chart (Figure 43).

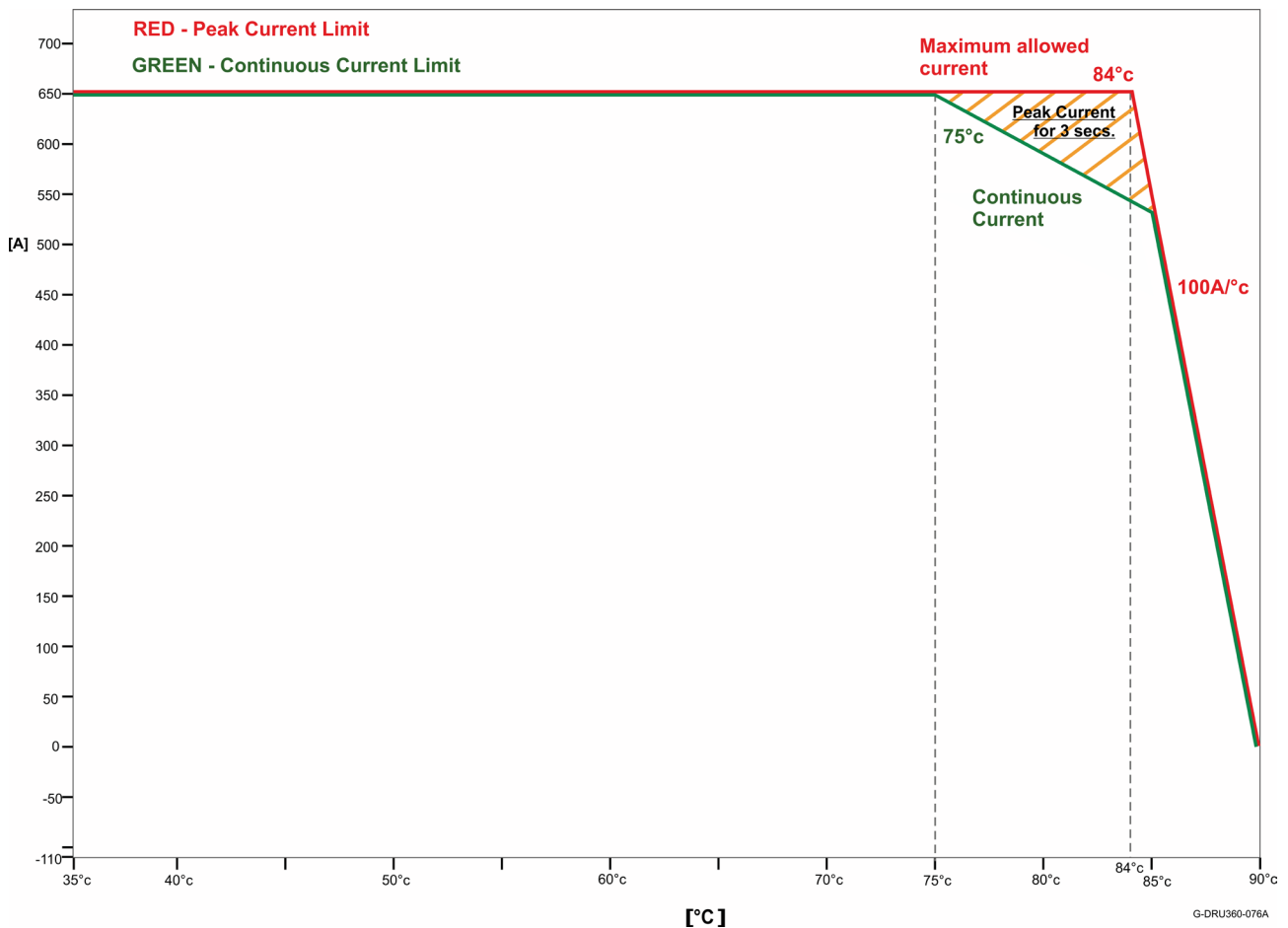

Figure 45: Thermal Operation for 650A under Continuous Current for both Voltage and Temperature

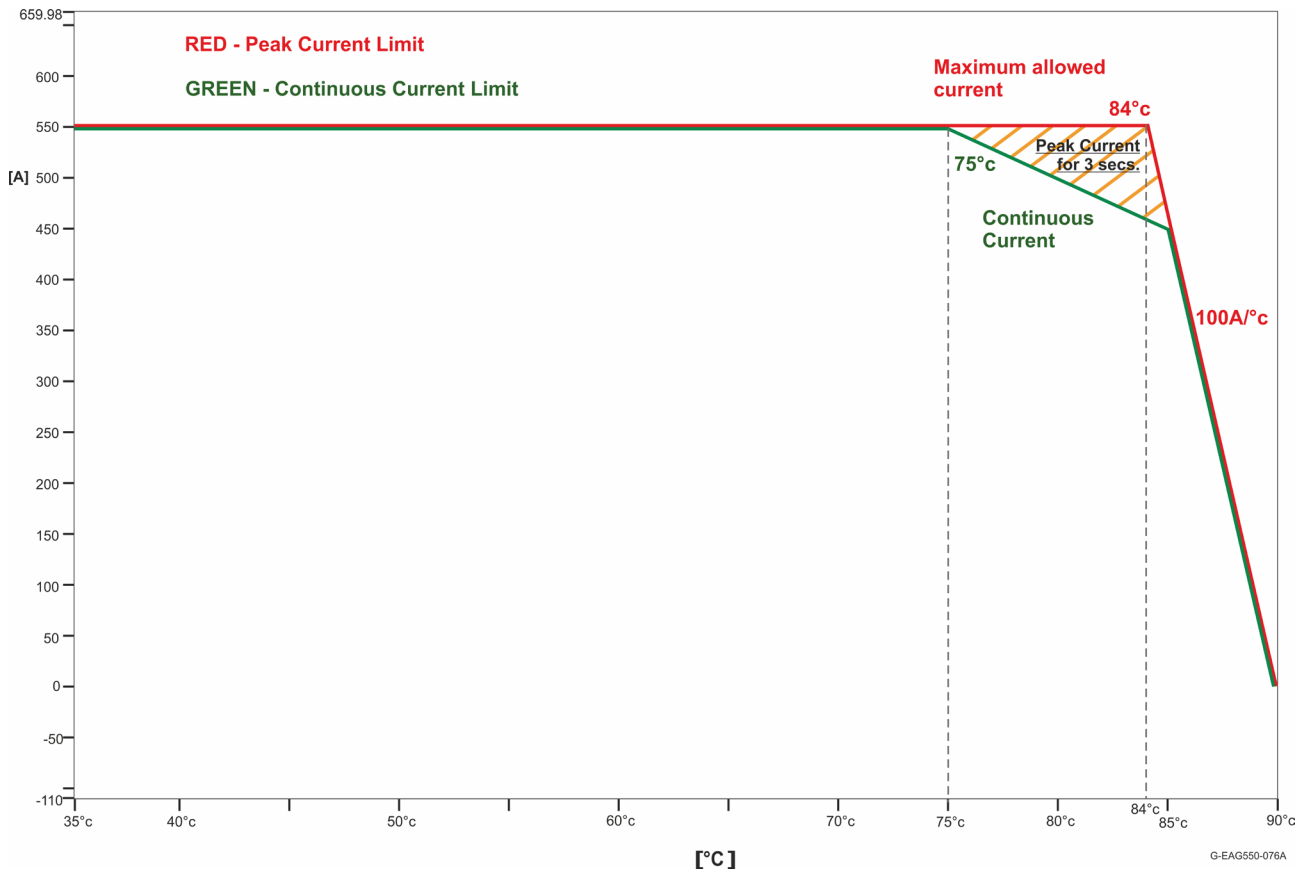

Figure 46: Thermal Operation for 550A under Continuous Current for both Voltage and Temperature

Up to a heat sink Temperature $T_{I[1]} \leq 75^{\circ}\text{C}$, the drive can provide a Max current of e.g. 550A continuously.

Between $75^{\circ}\text{C} \leq T_{I[1]} \leq 84^{\circ}\text{C}$ the Peak Current of 550A is allowed for up to 3 Seconds.

The limitation in this range is based on the standard drive's "RMS" current limit mechanism.

Check the Drive's Software Command Reference Manual under **PL/CL** operation for further explanation.

At the heat sink Temperature $T_{I[1]} > 84^{\circ}\text{C}$, the Drive's Peak Current limit (**PL**) is internally limited by the red/green line Linear slopes. The Current slope limit is $100\text{A}/^{\circ}\text{C}$, starting from $T_{I[1]} \geq 84^{\circ}\text{C}$.

This means, for example, that at a Temperature of $T_{I[1]} = 87^{\circ}\text{C}$, the Peak Current is limited to 250A.

At a Temperature of $T_{I[1]} \geq 89.5^{\circ}\text{C}$ the Output Current is 0.

Thermal Shut down (Motor Disabled) will be tripped at $T_{I[1]} = 92^{\circ}\text{C}$.



8. Powering Up

After the Gold Eagle 550/650 is connected to its device, it is ready to be powered up.



Caution:

Before applying power, ensure that the DC supply is within the specified range and that the proper plus-minus connections are in order.

8.1 Initializing the System

After the Gold Eagle 550/650 has been connected and mounted, the system must be set up and initialized. This is accomplished using the *EASII*, Elmo's Windows-based software application. Install the application and then perform setup and initialization according to the directions in the *EASII User Manual*.



9. Gold Eagle 550/650 Dimensions

This chapter provides detailed technical dimensions regarding the Gold Eagle 550/650.

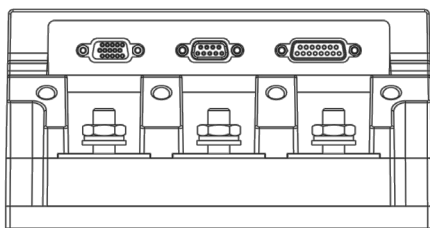
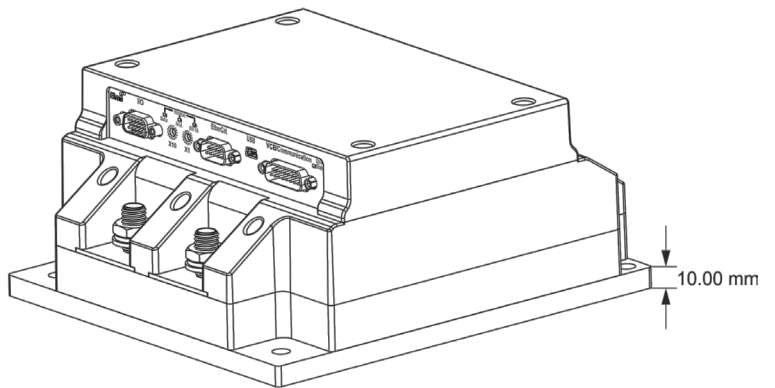
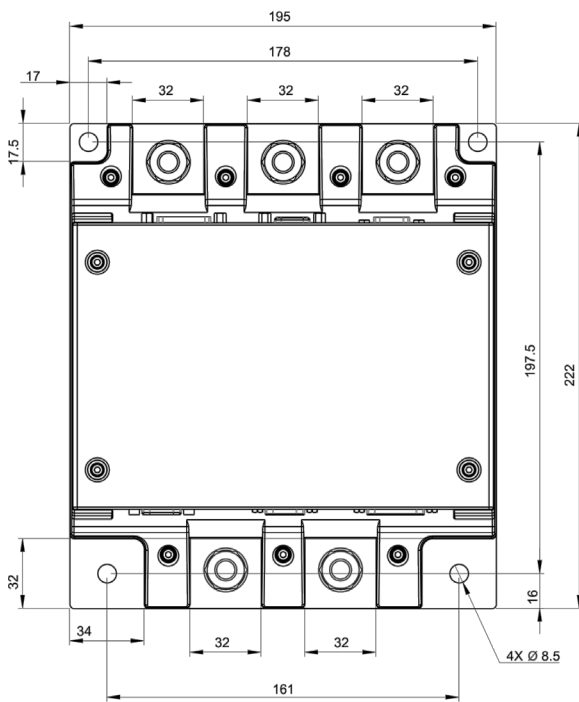
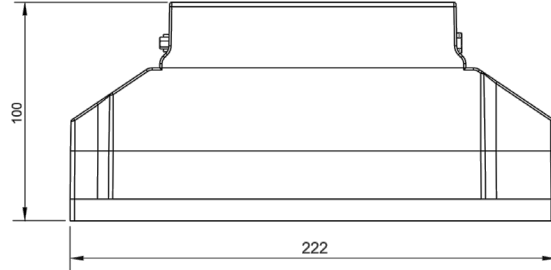
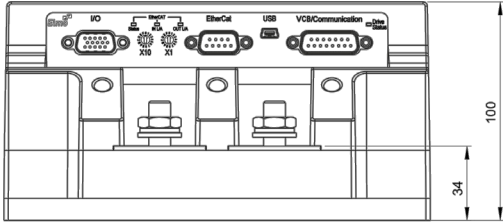

GEAG500-043B

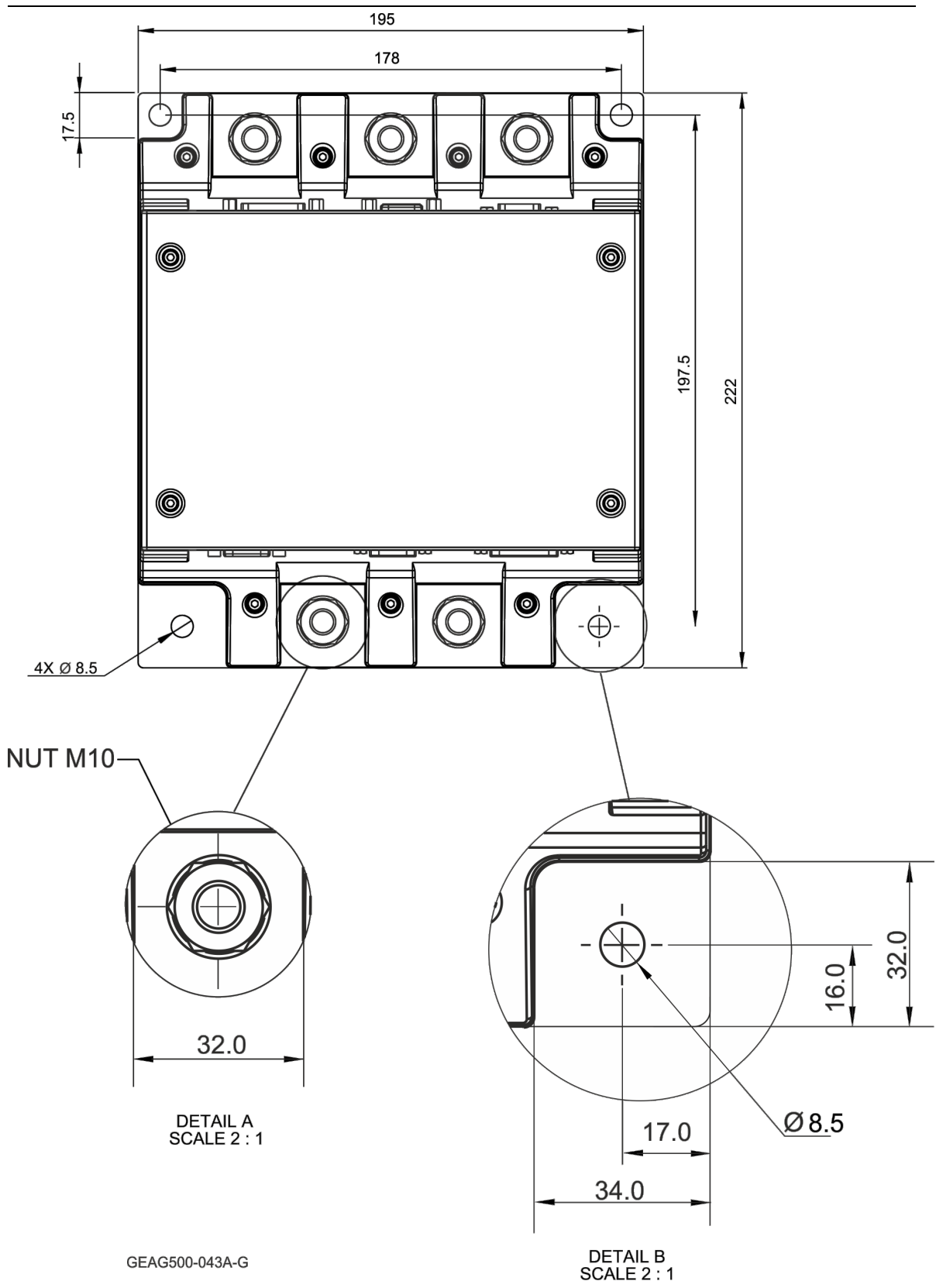

Inspiring Motion

Since 1988

For a list of Elmo's branches, and your local area office, refer to the Elmo site www.elmomc.com

