

Inspiring Motion

Since 1988

Gold Bee
160A/80V, 140A/100V
Digital Servo Drive
Installation Guide
CAN and EtherCAT



May 2018 (Ver. 1.001)

www.elmomc.com

Elmo
Motion Control

Notice

This guide is delivered subject to the following conditions and restrictions:

- This guide contains proprietary information belonging to Elmo Motion Control Ltd. Such information is supplied solely for the purpose of assisting users of the Gold Bee servo drive in its installation.
- The text and graphics included in this manual are for the purpose of illustration and reference only. The specifications on which they are based are subject to change without notice.
- Information in this document is subject to change without notice.

Document no. MAN-G-BEE_160 (Ver. 1.001)

Copyright © 2018

Elmo Motion Control Ltd.

All rights reserved.

Catalog Number

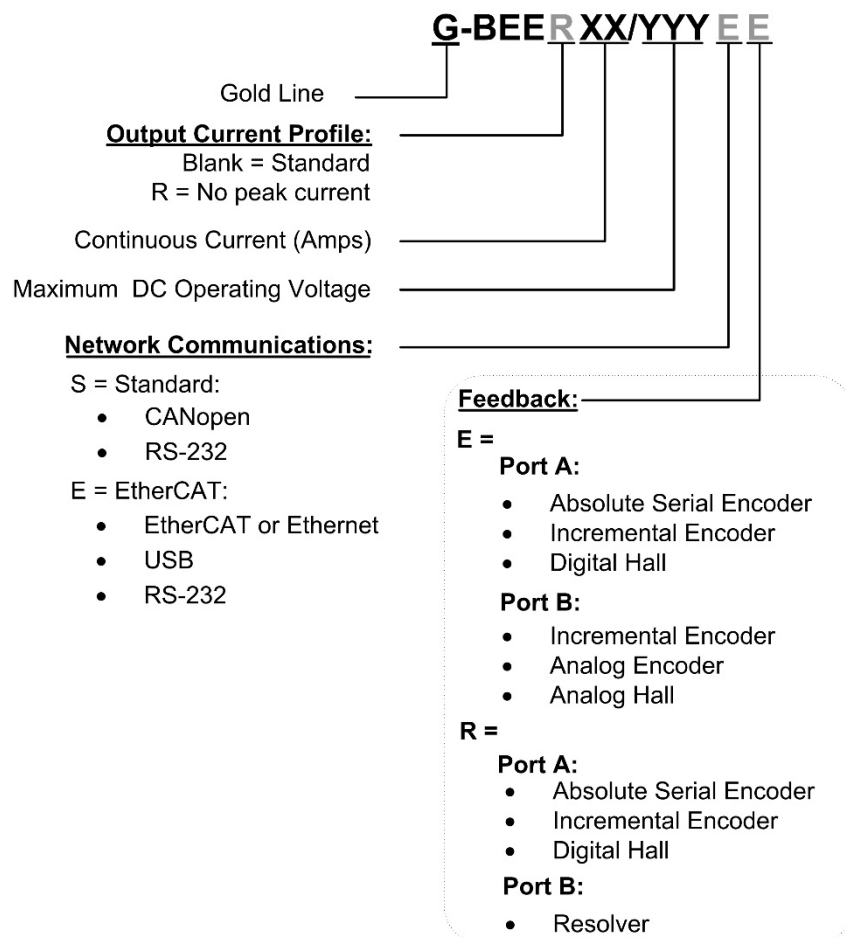

Revision History

Version	Date
Ver. 1.000	July 2017
Ver. 1.001	May 2018

Chapter 1: This Installation Guide	6
Chapter 2: Safety Information	6
2.1. Warnings	7
2.2. Cautions.....	7
2.3. CE Marking Conformance.....	7
2.4. Warranty Information	7
Chapter 3: Product Description.....	8
Chapter 4: Technical Information.....	9
4.1. Physical Specifications.....	9
4.2. R Type Technical Data	9
4.3. Control Supply Input Voltage (VL).....	10
4.4. Product Features	10
4.5. Environmental Conditions.....	11
Chapter 5: Unpacking the Drive Components	12
Chapter 6: Mounting the Gold Bee	13
6.1. Integrating the Gold Bee on a PCB.....	14
6.2. The Gold Bee Connection Diagram	14
Chapter 7: Wiring.....	16
7.1. Wiring Legend.....	16
Chapter 8: Connections	18
8.1. Main, Control, and Motor Power	21
8.1.1. Motor Power	21
8.1.2. Main Power and Control Connector.....	23
8.1.2.1. Main Power	23
8.1.2.2. Control Supply	24
8.1.2.3. Dual Power Supply Topology.....	25
8.1.2.4. Single Power Supply Topology.....	27
8.2. Feedback Connector FDB	29
8.2.1. Port A.....	31
8.2.1.1. Incremental Encoder	31
8.2.1.2. Absolute Serial Encoder.....	32
8.2.1.3. Hall Sensors	33
8.2.2. Port B.....	34

8.2.2.1.	Incremental Encoder	34
8.2.2.2.	Interpolated Analog Encoder	35
8.2.2.3.	Resolver	36
8.2.3.	Port C – Emulated Encoder Output (FDB)	37
8.3.	Main Connector (MAIN)	38
8.3.1.	LEDs	40
8.3.2.	STO (safety)	40
8.3.3.	Digital Inputs.....	41
8.3.4.	Digital Outputs.....	43
8.3.5.	STO (Safe Torque Off).....	46
8.3.6.	Analog Input	47
8.3.7.	CAN Option.....	48
8.3.7.1.	Interface	48
8.3.7.2.	CAN Layout	49
8.3.8.	RS232	50
8.4.	EtherCAT Module	52
8.4.1.	EtherCAT Module Connectors.....	52
8.4.1.1.	ECT2 connector.....	52
8.4.1.2.	ECT1 connector.....	53
8.4.1.3.	ECT3 Connector	53
8.4.1.4.	3.3V Connector	53
8.4.2.	EtherCAT Communication	54
8.4.3.	USB 2.0 Communication.....	56
Chapter 9:	Powering Up	57
9.1.	Initializing the System	57
9.2.	Heat Dissipation	58
9.2.1.	Heat Dissipation Data	58
9.2.2.	How to Use the Chart	59
Chapter 10:	Dimensions	61
10.1.	Gold Bee CAN Version	61
10.2.	Gold Bee EtherCAT Version	63



Chapter 1: This Installation Guide

This installation Guide details the technical data, pinouts, and power connectivity of the Gold Bee. For a comprehensive detailed description of the functions and connections of the drive, refer to the Gold Board Level Module Hardware Manual.

Chapter 2: Safety Information

In order to achieve the optimum, safe operation of the Gold Bee, it is imperative that you implement the safety procedures included in this installation guide. This information is provided to protect you and to keep your work area safe when operating the Gold Bee and accompanying equipment.

Please read this chapter carefully before you begin the installation process.

Before you start, ensure that all system components are connected to earth ground. Electrical safety is provided through a low-resistance earth connection.

Only qualified personnel may install, adjust, maintain and repair the servo drive. A qualified person has the knowledge and authorization to perform tasks such as transporting, assembling, installing, commissioning and operating motors.

The Gold Bee contains electrostatic-sensitive components that can be damaged if handled incorrectly. To prevent any electrostatic damage, avoid contact with highly insulating materials, such as plastic film and synthetic fabrics. Place the product on a conductive surface and ground yourself in order to discharge any possible static electricity build-up.

To avoid any potential hazards that may cause severe personal injury or damage to the product during operation, keep all covers and cabinet doors shut.

The following safety symbols are used in this and all Elmo Motion Control manuals:



Warning:

This information is needed to avoid a safety hazard, which might cause bodily injury or death as a result of incorrect operation.



Caution:

This information is necessary to prevent bodily injury, damage to the product or to other equipment.



Important:

Identifies information that is critical for successful application and understanding of the product.



2.1. Warnings

- To avoid electric arcing and hazards to personnel and electrical contacts, never connect/disconnect the servo drive while the power source is on.
- Power cables can carry a high voltage, even when the motor is not in motion. Disconnect the Gold Bee from all voltage sources before servicing.
- The high voltage products within the Gold Line range contain grounding conduits for electric current protection. Any disruption to these conduits may cause the instrument to become hot (live) and dangerous.
- After shutting off the power and removing the power source from your equipment, wait at least 3 minutes before touching or disconnecting parts of the equipment that are normally loaded with electrical charges (such as capacitors or contacts). Measuring the electrical contact points with a meter, before touching the equipment, is recommended.



2.2. Cautions

- The maximum DC power supply connected to the instrument must comply with the parameters outlined in this guide.
- When connecting the Gold Bee to an approved control supply, connect it through a line that is separated from hazardous live voltages using reinforced or double insulation in accordance with approved safety standards.
- Before switching on the Gold Bee, verify that all safety precautions have been observed and that the installation procedures in this manual have been followed.
- Make sure that the Safe Torque Off is operational

2.3. CE Marking Conformance

The Gold Bee is intended for incorporation in a machine or end product. The actual end product must comply with all safety aspects of the relevant requirements of the European Safety of Machinery Directive 2006/42/EC as amended, and with those of the most recent versions of standards EN 60204-1 and EN ISO 12100 at the least, and in accordance with 2006/95/EC.

Concerning electrical equipment designed for use within certain voltage limits, the Gold Bee meets the provisions outlined in 2006/95/EC. The party responsible for ensuring that the equipment meets the limits required by EMC regulations is the manufacturer of the end product.

2.4. Warranty Information

The products covered in this manual are warranted to be free of defects in material and workmanship and conform to the specifications stated either within this document or in the product catalog description. All Elmo drives are warranted for a period of 12 months from the time of shipment. No other warranties, expressed or implied — and including a warranty of merchantability and fitness for a particular purpose — extend beyond this warranty.



Chapter 3: Product Description

The Ultra High Current Gold Bees which can deliver up to 160A @ up to 75VDC and 140A @ up to 95VDC are advanced high power density servo drives, delivering up to **10 kW power** in a 32 cm³(2 Inch³) compact package 47 x 36.2 x 18.8 mm (1.85" x 1.425" x 0.74"). The Gold Bee is designed to be mounted on a PCB by soldering its pins directly to the PCB.

This advanced, high power density servo drive provides top performance, advanced networking and built-in safety, as well as a fully featured motion controller and local intelligence. Power to the Gold Bee is provided by a DC power source which is isolated from the Mains. The Gold Bee can operate with single or dual power supplies. If separation between the main DC power source and a control supply is required, then a control supply (isolated from the Mains) is required.

The drive can operate as a stand-alone device or as part of a multi-axis system in a distributed configuration on a real-time network.

The Gold Bee drive is easily set up and tuned using the Elmo Application Studio (EASII) software tools. As part of the Gold product line, it is fully programmable with the Elmo motion control language. For more information about software tools refer to the Elmo Application Studio (EASII) User Guide.

The Gold Bee is available in a variety of models. There are multiple power rating options, different communications options, a number of feedback options and different I/O configuration possibilities.

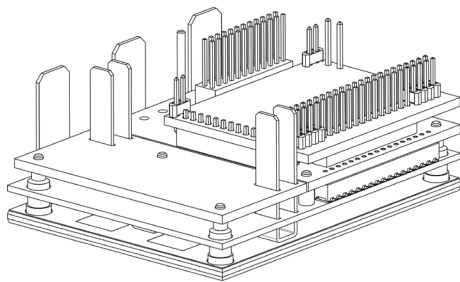

ETHERCAT MODULE

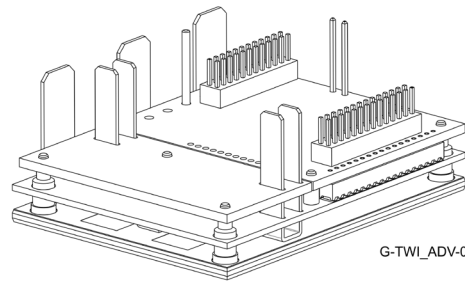

G-TWI_ADV-003A

CAN MODULE

Figure 1: Difference between 3-Tier CAN and 4-Tier EtherCAT modules

Within the variety of models offered, the CAN and EtherCAT versions are physically different in that the CAN version has three tiers, whereas the EtherCAT version has four tiers, as shown in Figure 1.

Optionally, where necessary, Elmo offers an external heat sink which must be ordered separately.



Chapter 4: Technical Information

4.1. Physical Specifications

Feature	Units	All Types
Weight	g (oz)	EtherCAT Version: ≈36 g (1.27 oz) CAN Version: ≈33 g (1.16 oz)
EtherCAT Version Dimension	mm (in)	47 x 36.2 x 18.8 mm (1.85" x 1.425" x 0.74")
CAN Version Dimension	mm (in)	47 x 36.2 x 18.8 mm (1.85" x 1.425" x 0.74")
Mounting method		PCB mount
IP		IP00

4.2. R Type Technical Data

Feature	Units	R160/80	R140/100
Minimum supply voltage	VDC	11	11
Nominal supply voltage	VDC	65	85
Maximum supply voltage	VDC	75	95
Maximum continuous Electrical power output	kW	10	11
Efficiency at rated power (at nominal conditions)	%	> 99	
Maximum output voltage		Up to 96% of DC bus voltage	
Amplitude sinusoidal/DC continuous current	A	160	140
Not for DC Motor Sinusoidal continuous RMS current limit (I _c)	A	113	99
For DC Motor only	A	100	
Current limit	A	Max Output current is guaranteed for T _{Heat-Sink} <85°C	



4.3. Control Supply Input Voltage (VL)

The Control Supply input voltage (VL) must be either SELV or PELV rated.

Feature	Unit	Details
Standard CAN (S option)		
Input range	V	11V – 95V
Power consumption (including 5 V/200 mA for encoder)	W	<2.5W
ETHERCAT (E option)		
Input range	V	11V – 95V
Power consumption (including 5 V/200 mA for encoder)	W	<4W

4.4. Product Features

Main Feature	Details	Presence / No.
STO	5V Logic Level, Opto isolated from the Control section	✓
Digital Input Option	5V Logic Level (Internally connected to COMRET)	6
Digital Output Option	5V logic (Internally connected to COMRET)	2
	3.3V logic (Internally connected to COMRET)	2
Analog Input	Differential ±10V	1
	Single Ended	1
Feedback	Standard Port A, B, & C	✓
Communication Option	USB	✓
	EtherCAT	✓
	CAN	✓
	RS232 TTL level	✓
	Standard RS232	✓



4.5. Environmental Conditions

You can guarantee the safe operation of the Gold Bee by ensuring that it is installed in an appropriate environment.

For functional safety (STO), the related standards stated in the MAN-G-Board Level Modules Hardware Manual section 17.1 apply to the performance of the servo drives as stated in the environmental conditions within the same document, section 15.1 Gold Line.

The ExtriQ series of drives support the following extended environmental conditions.

Feature	Operation Conditions	Range
Ambient Temperature Range	Non-operating conditions	-50 °C to +100 °C (-58 °F to 212 °F)
	Operating conditions	-40 °C to +70 °C (-40 °F to 160 °F)
Temperature Shock	Non-operating conditions	-40 °C to +70 °C (-40 °F to 160 °F) within 3 min
Altitude	Non-operating conditions	Unlimited
	Operating conditions	-400 m to 12,000 m (-1312 to 39370 feet)
Maximum Humidity	Non-operating conditions	Up to 95% relative humidity non-condensing at 35 °C (95 °F)
	Operating conditions	Up to 95% relative humidity non-condensing at 25 °C (77 °F), up to 90% relative humidity non-condensing at 42 °C (108 °F)
Vibration	Operating conditions	20 Hz to 2,000 Hz, 14.6 g
Mechanical Shock	Non-operating conditions	±40g; Half sine, 11 msec
	Operating conditions	±20g; Half sine, 11 msec
Protection level		IP00



Chapter 5: Unpacking the Drive Components

Before you begin working with the Gold Bee, verify that you have all of its components, as follows:

- The Gold Bee servo drive
- The Elmo Application Studio (EASII) software and software manual

The Gold Bee is shipped in a cardboard box with Styrofoam protection.

To unpack the Gold Bee:

1. Carefully remove the servo drive from the box and the Styrofoam.
2. Check the drive to ensure that there is no visible damage to the instrument. If any damage has occurred, report it immediately to the carrier that delivered your drive.
3. To ensure that the Gold Bee you have unpacked is the appropriate type for your requirements, locate the part number sticker on the side of the Gold Bee. It looks like this:



GBEE_ADV-080A

4. Verify that the Gold Bee type is the one that you ordered, and ensure that the voltage meets your specific requirements.
The part number at the top provides the type designation. Refer to the appropriate part number in the section Catalog Number at the beginning of the installation guide.



Chapter 6: Mounting the Gold Bee

The Gold Bee was designed for mounting on a printed circuit board (PCB) via 1.27 mm pitch 0.40 mm square pins, 2 mm pitch 0.51 mm square pins and 3.65 mm pitch 1.02 mm round pins. When integrating the Gold Bee into a device, be sure to leave about 1 cm (0.4") outward from the heat-sink to enable free air convection around the drive. We recommend that the Gold Bee be soldered directly to the board (see detail diagrams in Chapter 10: Dimensions. If the PCB is enclosed in a metal chassis, we recommend that the Gold Bee be screw-mounted to it as well to help with heat dissipation. The Gold Bee has screw-mount holes on each corner of the heat-sink for this purpose – see below

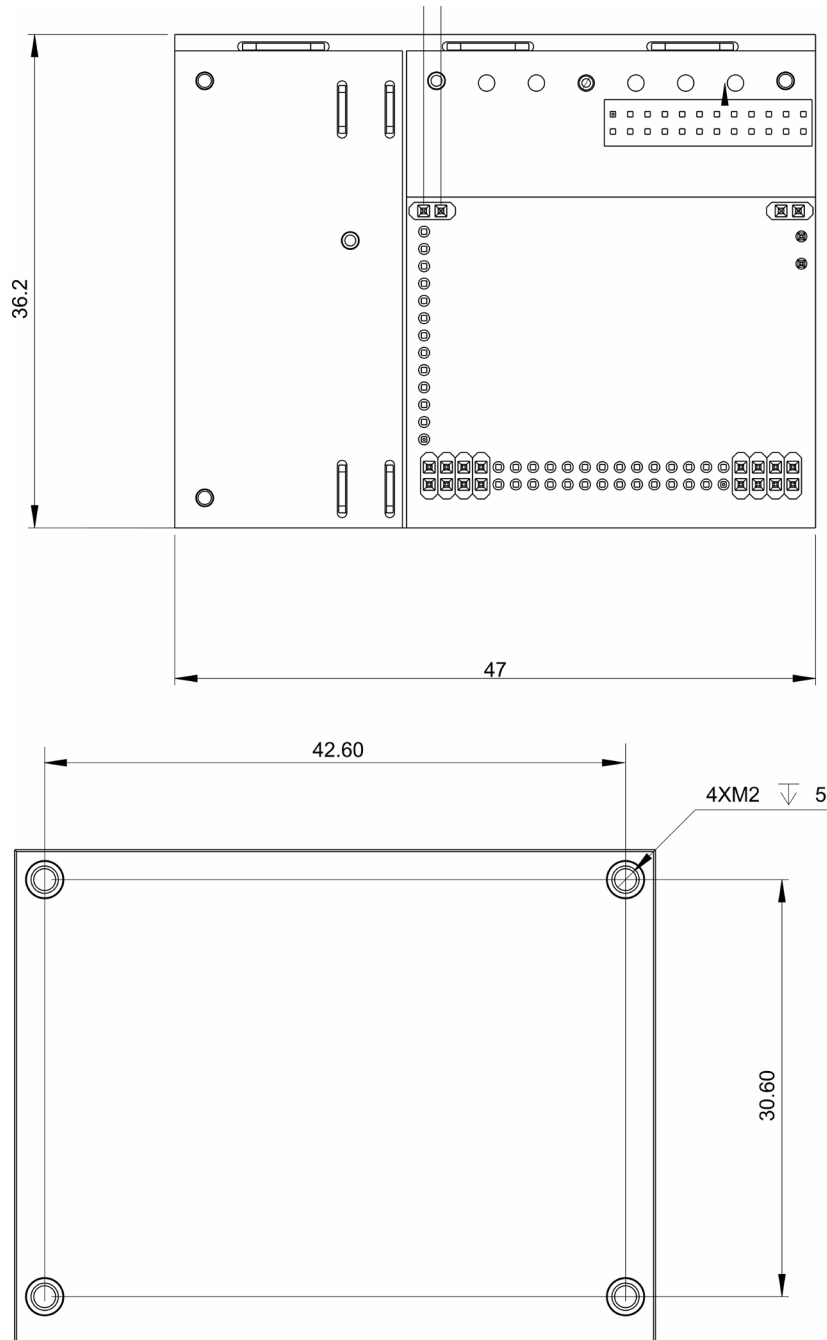

G-TWL_ADV-011A

Figure 2: Gold Bee Version Dimensions



6.1. Integrating the Gold Bee on a PCB

The Gold Bee is designed to be mounted on a PCB by soldering its pins directly to the PCB.

6.2. The Gold Bee Connection Diagram

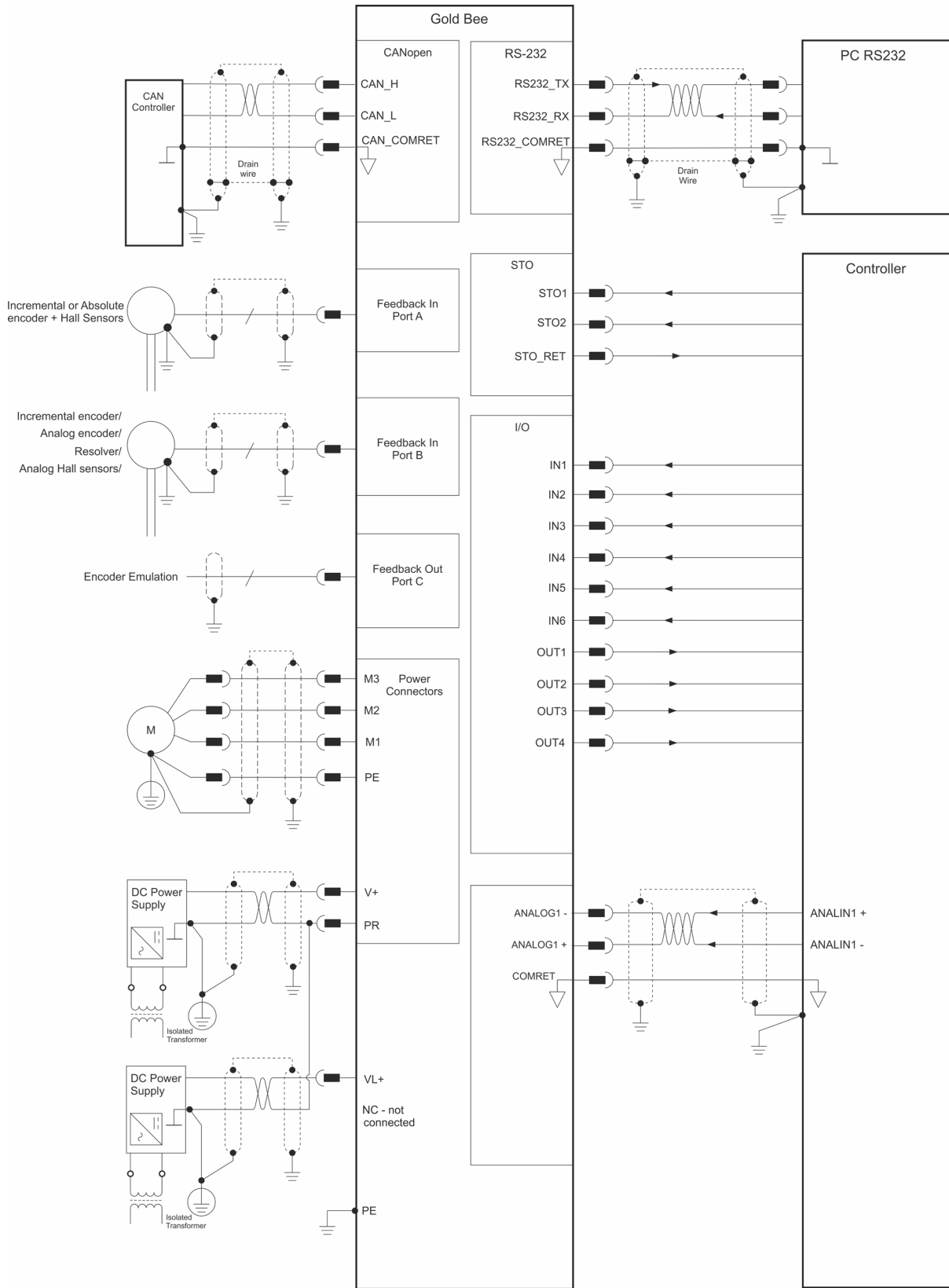

GBEE_ADV-180A

Figure 3: The Gold Bee CAN Connection Diagram

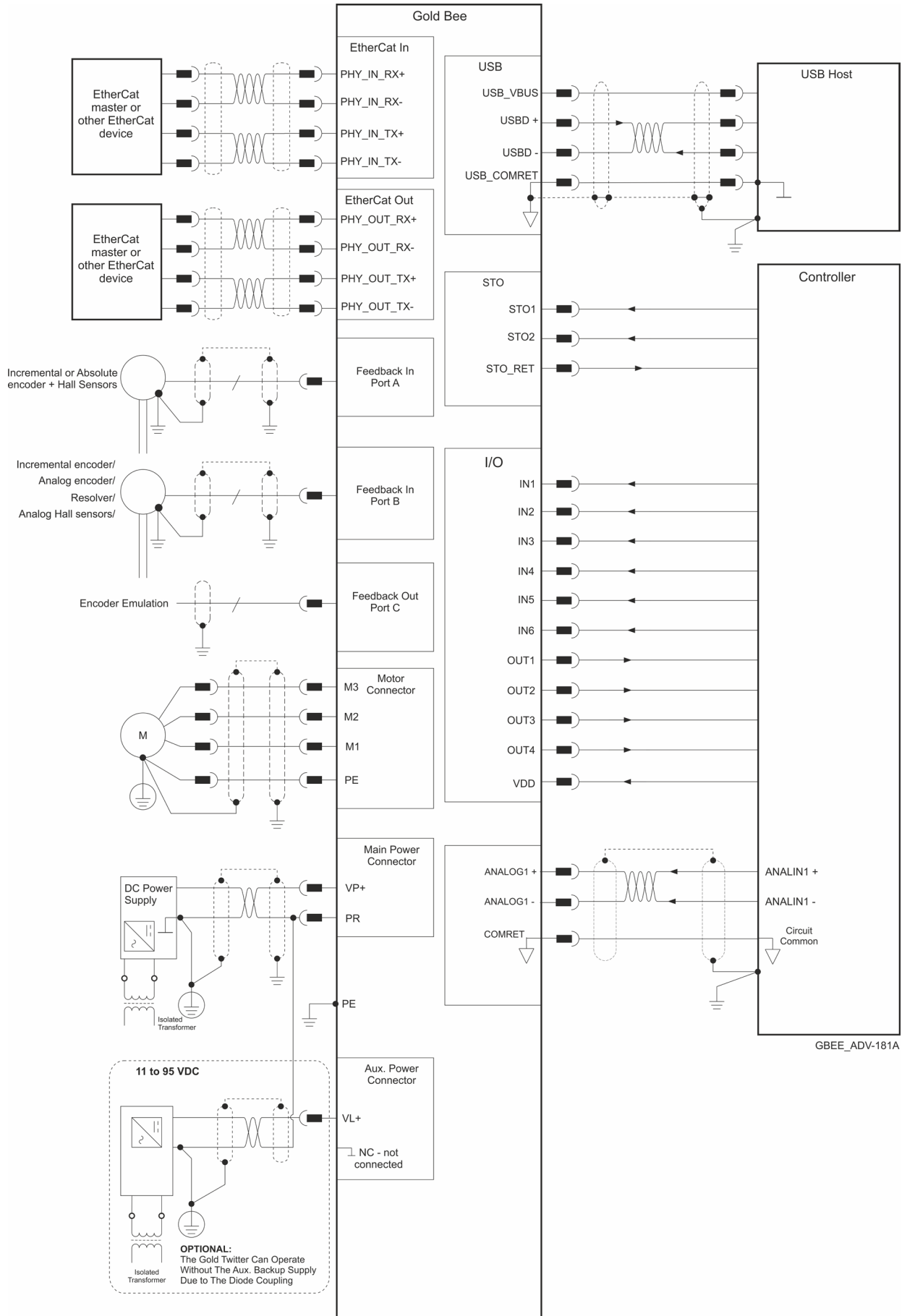





Figure 4: The Gold Bee EtherCAT Connection Diagram



Chapter 7: Wiring

7.1. Wiring Legend

The following table legend describes the wiring symbols detailed in all installation guides. All the wiring diagrams show wiring for D-TYPE connectors.

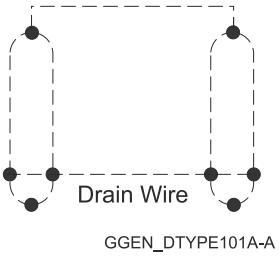
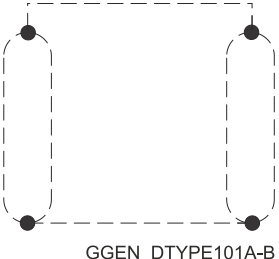
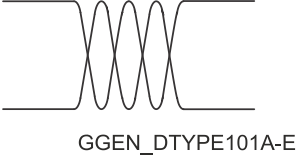
Wiring Symbol	Description
	Earth connection (PE)
	Protective Earth Connection
	Common at the Controller
	Shielded cable with drain wire. The drain wire is a non-insulated wire that is in direct contact with the braid (shielding). Shielded cable with drain wire significantly simplifies the wiring and earthing.
	Shielded cable braid only, without drain wire.
	Twisted-pair wires

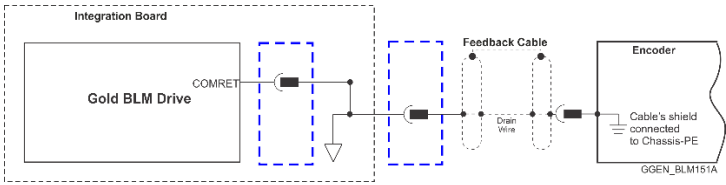

Wiring Symbol	Description
 <p>The diagram illustrates the wiring for encoder earthing. On the left, an 'Integration Board' contains a 'Gold BLM Drive' with a 'COMRET' terminal. A 'Feedback Cable' is connected to this terminal. The cable's shield is connected to the chassis (PE) in the connector. The encoder is connected to the other end of the feedback cable. The diagram is labeled 'GGEN_BLM151A'.</p>	<p>Encoder Earthing.</p> <p>The cable's shield is connected to the chassis (PE) in the connector.</p> <p>Earthing the Encoder and connecting the Earth (PE) to the drive COMRET is mandatory to insure reliable operation, high noise immunity and rejection of voltage common mode interferences.</p>



Chapter 8: Connections

The Gold Bee has nine connectors.

Port	Pins	Type	Function
FDB	2x12	1.27 mm pitch 0.40 mm sq.	Feedbacks, Digital Halls, Analog Inputs, Communications
M3	1x1	3.65 mm pitch 1.02 mm round pins	Motor power output 3
M2	1x1		Motor power output 2
M1	1x1		Motor power output 1
PE	1x1		Protective earth
PR	1x1		Power output return
VP+	1x1		DC Positive power input
VL+	1x2	2 mm pitch 0.51 mm sq.	VL+
NC			Terminal not connected
MAIN	2x14	1.27 mm pitch 0.40 mm sq.	I/O, LEDs, STO, CAN or EtherCAT
ECT1	2x4	1.27 mm pitch 0.40 mm sq.	Available only for EtherCAT Version
ECT2	2x4	1.27 mm pitch 0.40 mm sq.	Available only for EtherCAT Version
ECT3	1x2	1.27 mm pitch 0.40 mm sq.	Available only for EtherCAT Version
3.3 V	1x2	1.27 mm pitch 0.40 mm sq.	Available only for EtherCAT Version Only for LEDS end Transformer



Connectors Location

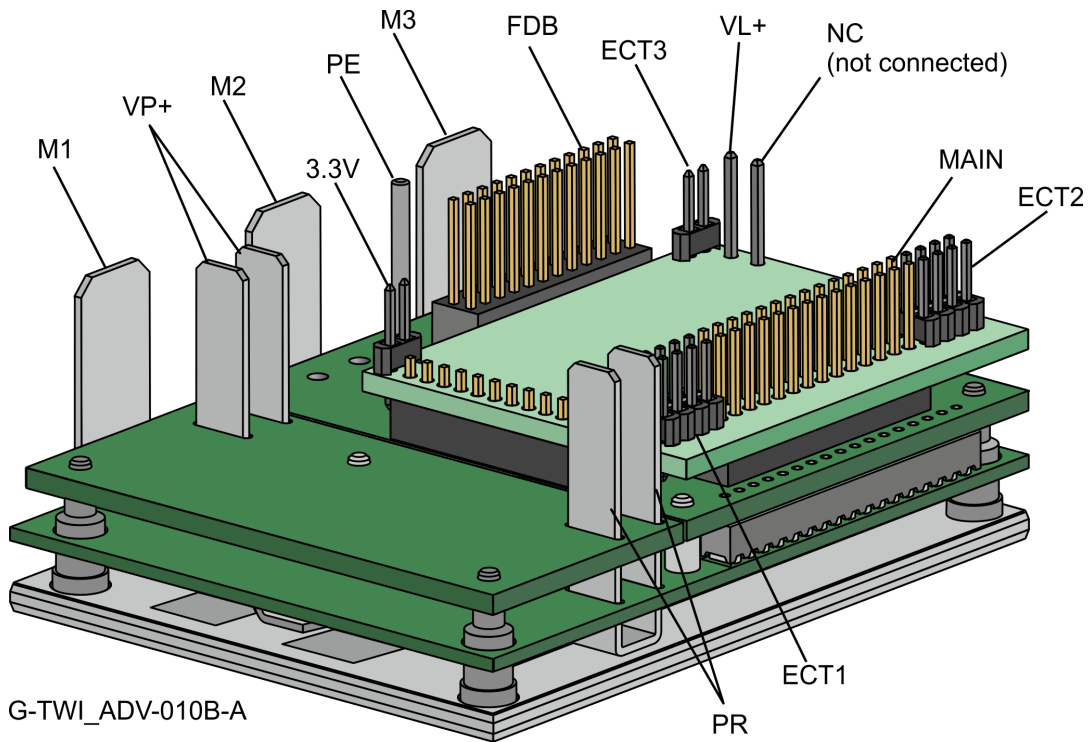

EtherCAT Version

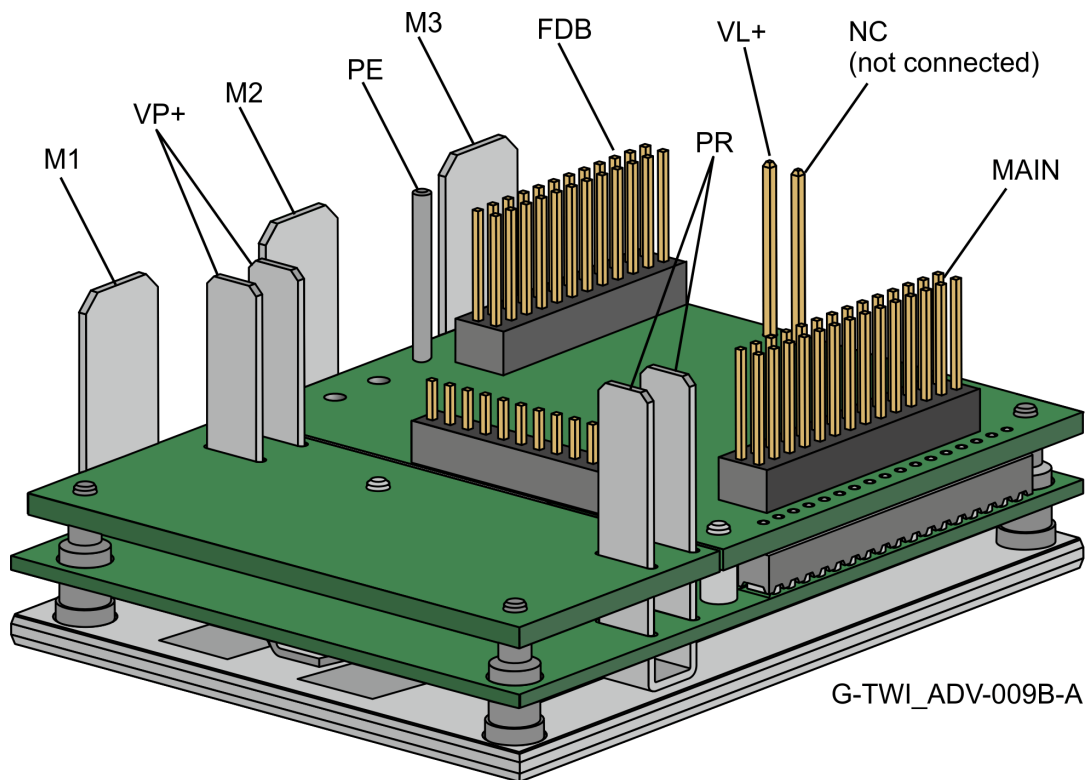

CAN Version

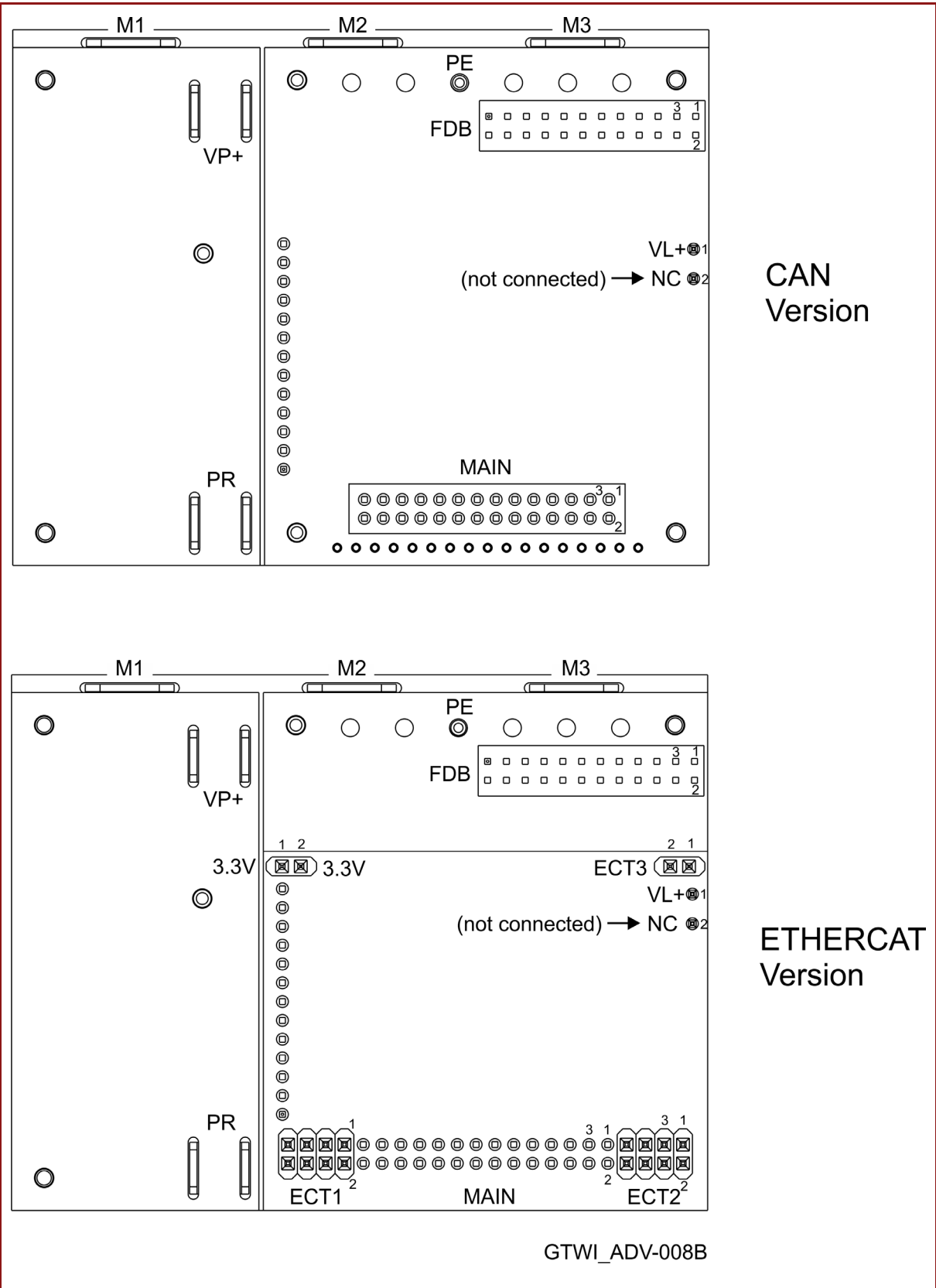

Table 1: Connector Types



8.1. Main, Control, and Motor Power

This section describes the Main, Control, and Motor Power.

8.1.1. Motor Power

For full details see Section 7.3 in the manual: MAN-G-Board Level Modules Hardware manual.

Pin	Function	Cable		Pin Positions
		Brushless Motor	Brushed DC Motor	
PE	Connection earth	Motor	Motor	
M1	Motor phase	Motor	N/C	
M2	Motor phase	Motor	Motor	
M3	Motor phase	Motor	Motor	

Table 2: Motor Connector

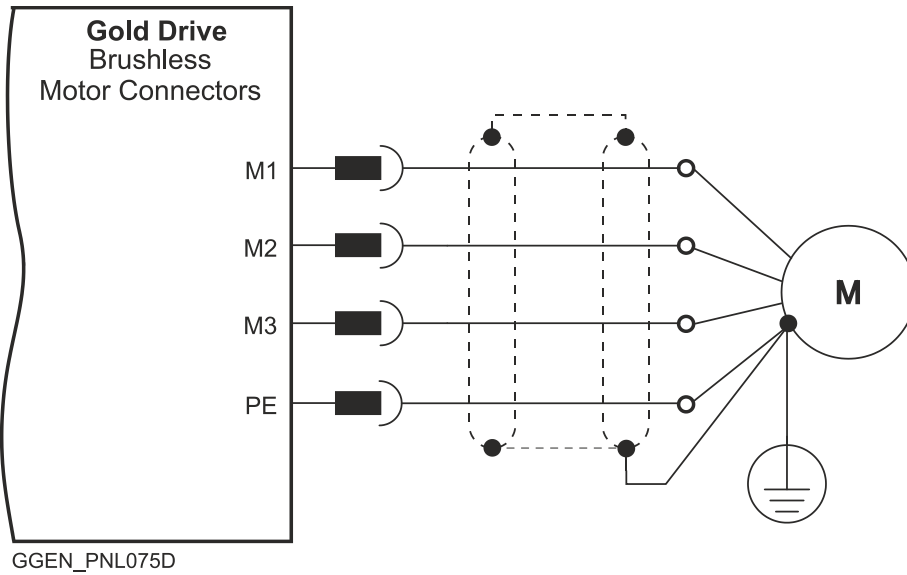

GGEN_PNL075D

Figure 5: Brushless Motor Power Connection Diagram

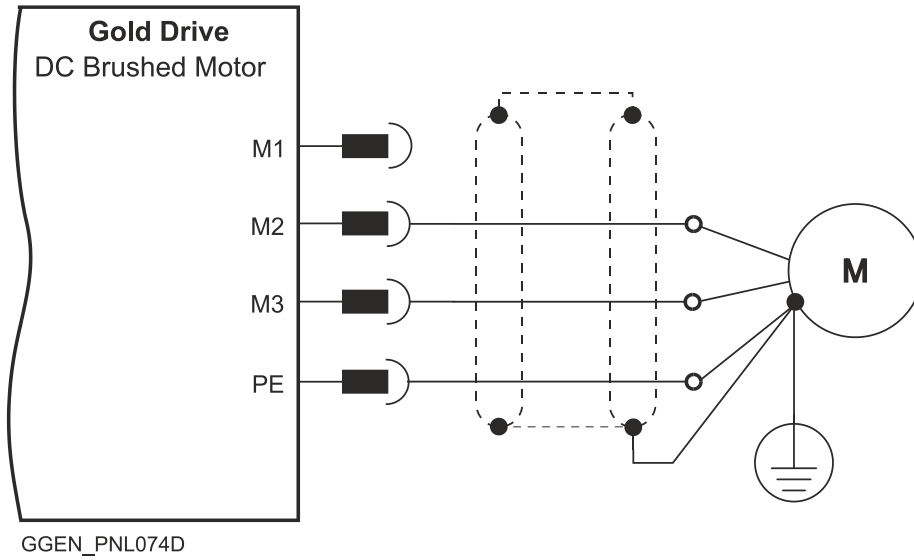

Figure 6: Brushed Motor Power Connection Diagram



8.1.2. Main Power and Control Connector

This section describes the Main Power and the Control supply connector.

8.1.2.1. Main Power

The VDC isolated from the Mains DC power source is not included with the Gold Bee.

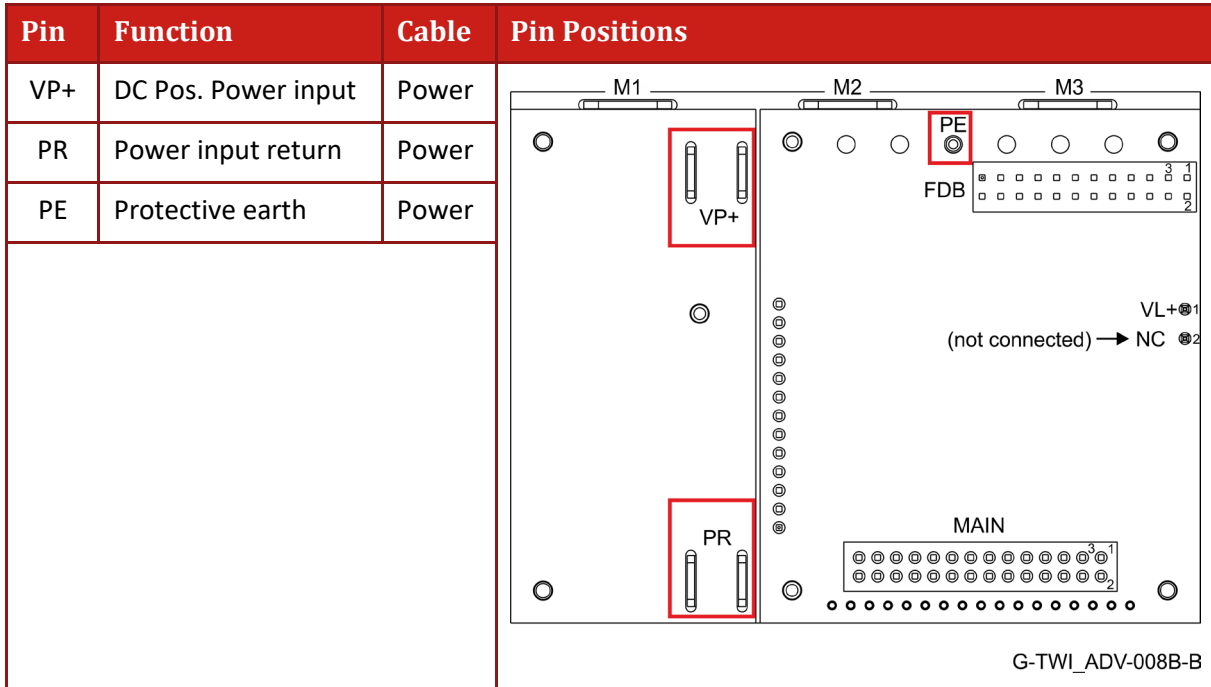

Table 3: Connector for Main Power

Connect the DC power cable to the VP+ and PR terminals on the main power connector.

To connect your integration board to the DC power source:

1. The source of the VDC power supply must be isolated from the Mains.
2. For best immunity, it is highly recommended to use twisted and shielded cables for the DC power supply. A 3-wire shielded cable should be used. The gauge is determined by the actual current consumption of the motor.
3. Connect the cable shield to the closest earth connection near the power supply.
4. Connect the PE to the closest earth connection near the power supply.
5. Connect the PR to the closest earth connection near the power supply.
6. Before applying power, first verify the polarity of the connection.



8.1.2.2. Control Supply

Connect the VL+ pin on the Gold Bee in the manner described in the table and drawing below.

Pin	Signal	Function	Pin Positions
1	VL+	Control Supply Input	
2	NC	Not connected	

1. Standard CAN (S option)
 Input range: 11VDC – 95VDC
 Power consumption: <2.5W
 (including 5 V/200 mA for encoder)

2. EtherCAT (E option)
 Input range: 11VDC – 95VDC
 Power consumption: <4W
 (including 5 V/200 mA for encoder)

Table 4: Control Supply Pins

Connect the VL+ terminal to the Control Connector. Make sure that the VL- terminal of the control supply is connected to the PR of the DC bus power supply

To connect your integration board to the control supply:

1. The source of the control supply must be isolated from the Mains.
2. Connect the cable shield to the closest earth connection near the control supply source
3. Before applying power, first verify the polarity of the connection.



8.1.2.3. Dual Power Supply Topology

Two DC power sources isolated-from-the-mains are required:

- A main DC power source derived from the Mains, according to specification
- A control supply for the logic

8.1.2.3.a Ordinary Option

This option describes an Ordinary power supply for Servo drives with sufficient internal capacitance and shunt regulator to handle power flow in both directions to-and-from the motor. The following figure describes this connection of main power and control power.

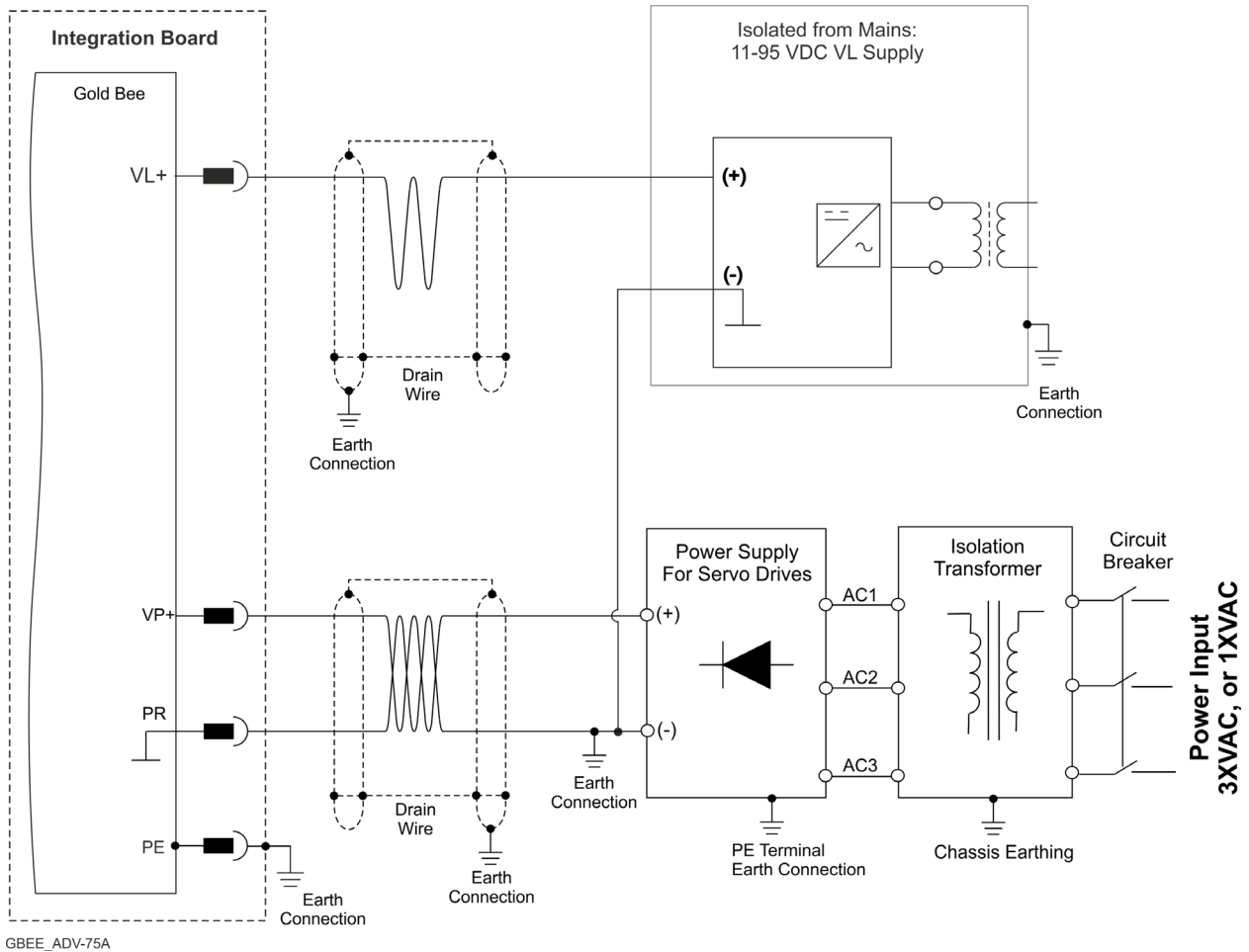

Figure 7: Ordinary Option: Separate VP and VL Power Supplies Connection Diagram



8.1.2.3.b SMPS Option

This option describes a topology with a main power without regeneration, but with limited Braking capabilities dependent on additional capacitance.

The C_{external} can be mounted on the Integration Board if there are no space limitations.

Minimum capacitance of the Power supply: $C_{\text{external}} > \text{“Drive’s Rated Current”} * 20\mu\text{F}$

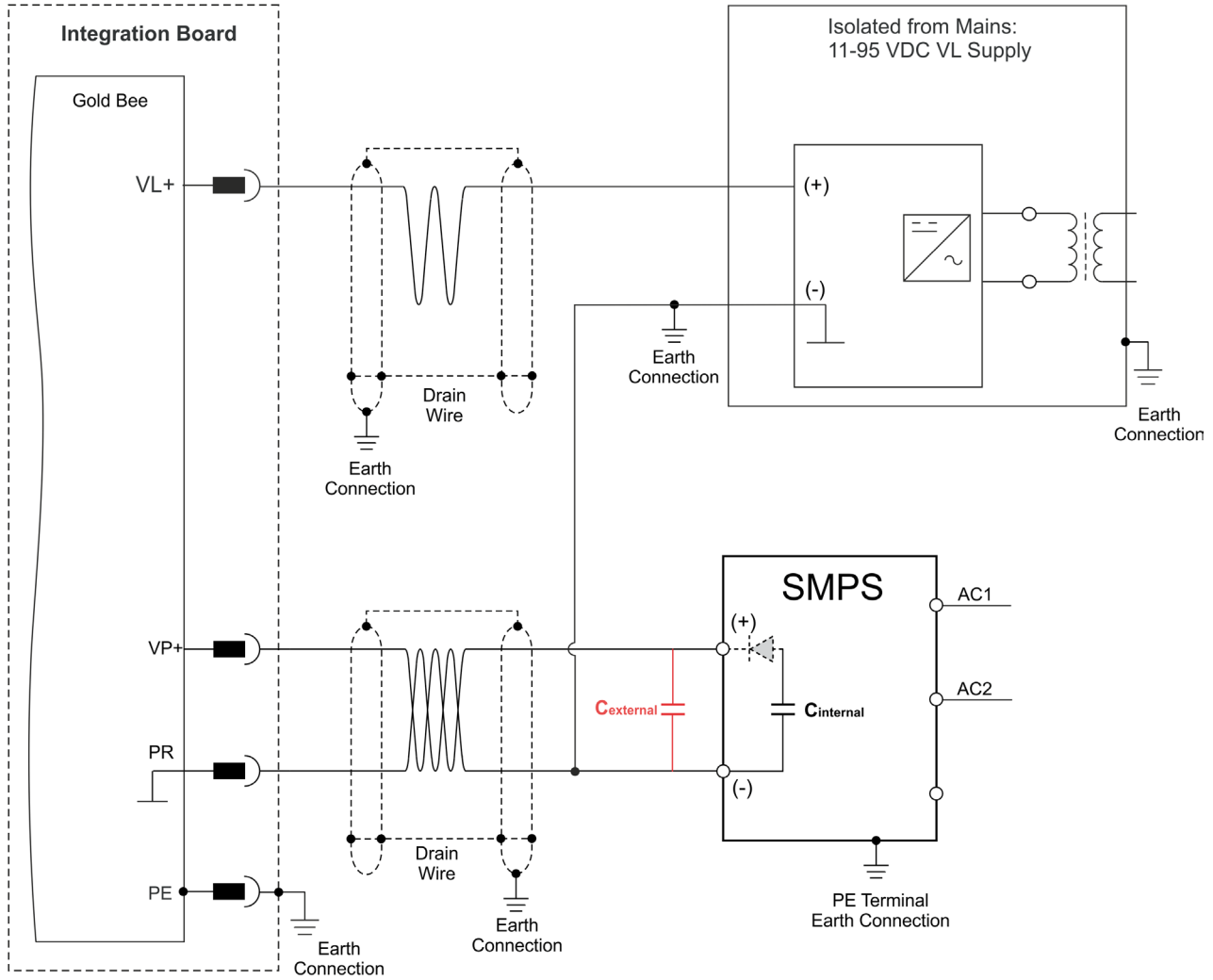

GBEE_ADV-076A

Figure 8: SMPS Option: Separate VP and VL Power Supplies Connection Diagram



8.1.2.4. Single Power Supply Topology

A single power supply can be used to power both the main and control. For the 80V version, the power voltage rating is 11VDC to 75VDC, or a minimum 11VDC. For the 100V version, the power voltage rating is 11VDC to 95VDC.

8.1.2.4.a Recommended Option

This option describes an Ordinary power supply for Servo drives with sufficient internal capacitance and shunt regulator to handle power flow in both directions to-and-from the motor. The following figure describes this connection of main power and control.

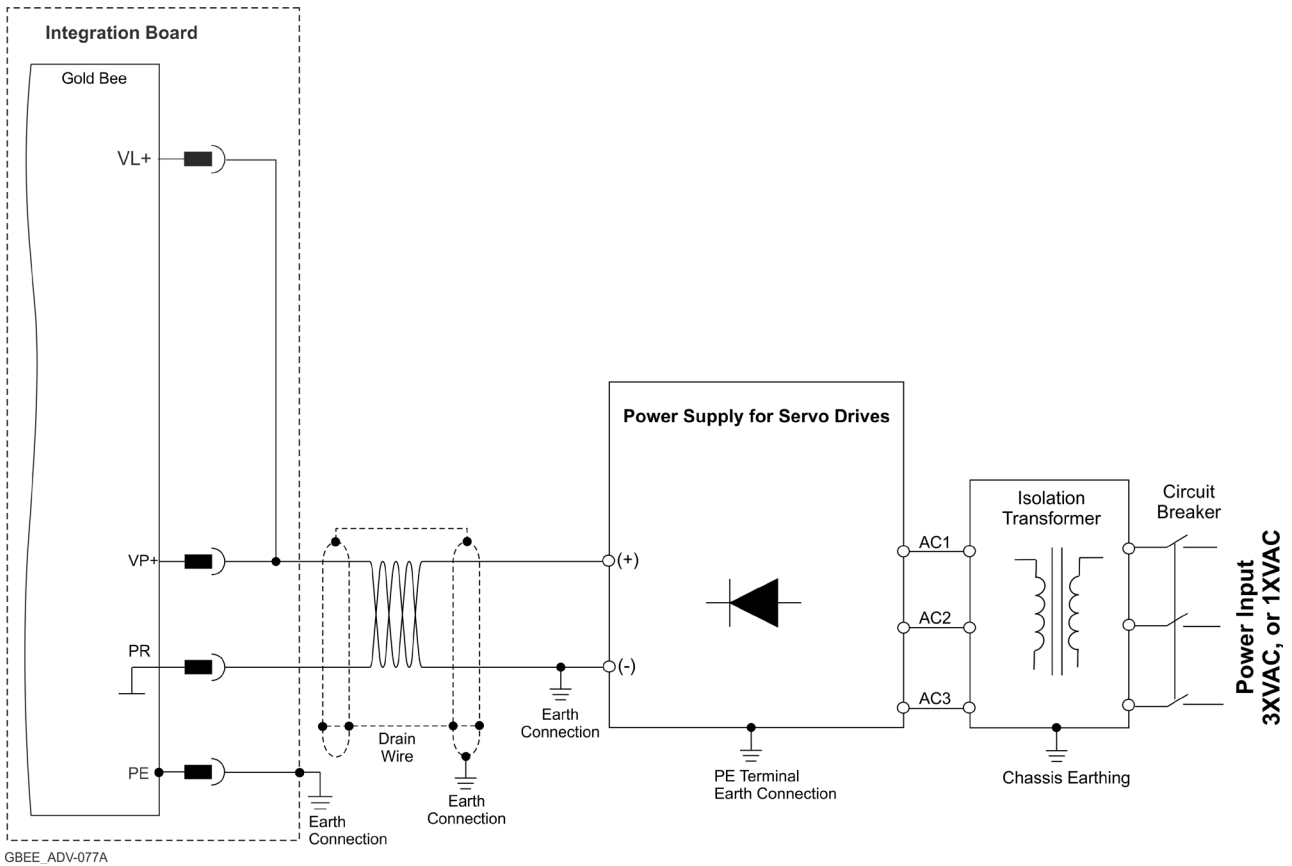

Figure 9: Recommended Single Power Supply (VP<75VDC for “80V”, VP+<95V for “100V”) Connection Diagram with VL+ Connected Internally



8.1.2.4.b SMPS Option

This option describes a main power and control topology without regeneration, but with limited Braking capabilities dependent on additional capacitance.

The $C_{external}$ can be mounted on the Integration Board if there are no space limitations.

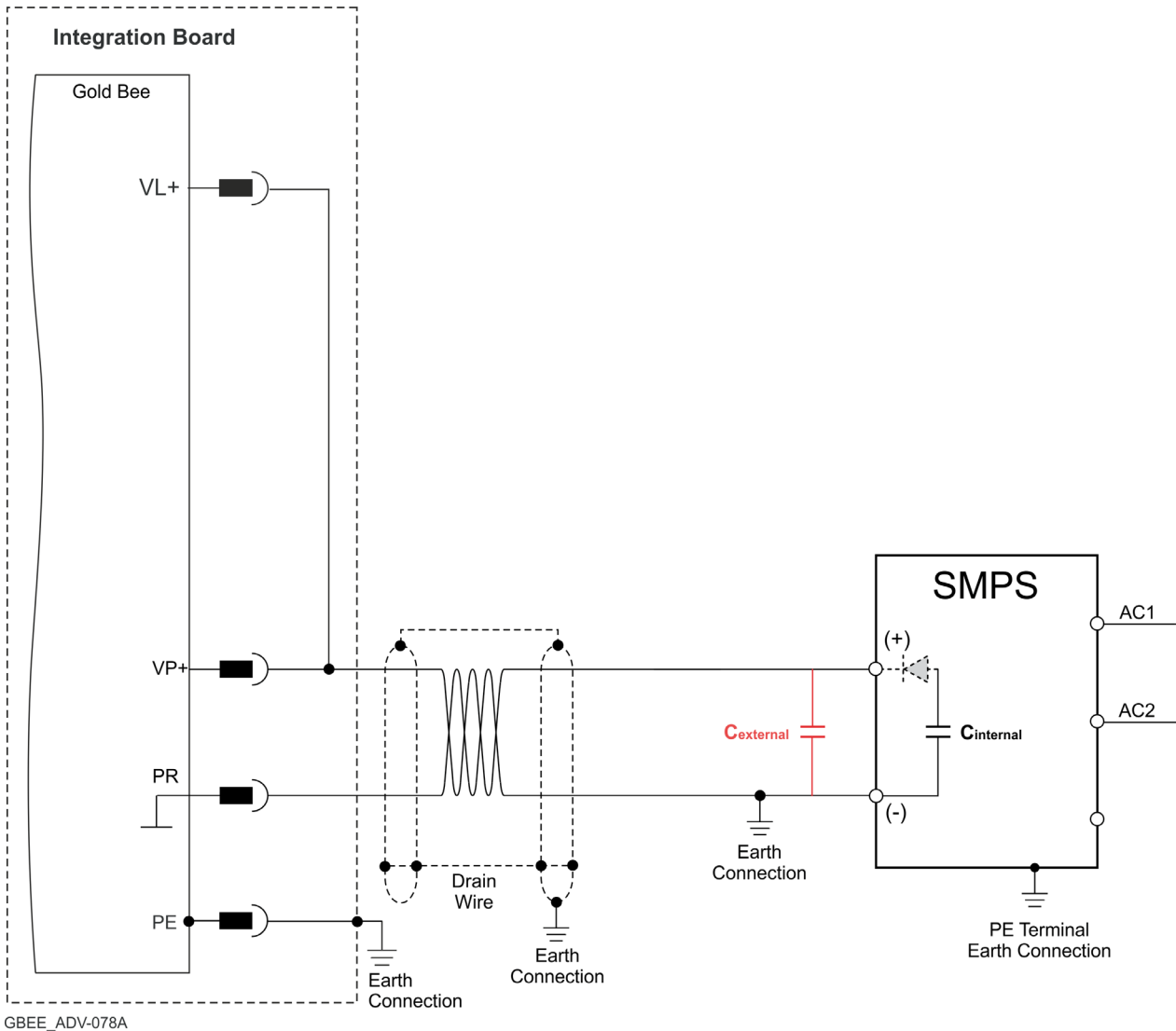

Figure 10: SMPS Single Power Supply ($VP < 75VDC$ for "80VDC", $VP < 95V$ for "100VDC") Connection Diagram with VL+ Connected Internally

For applications where a SMPS single power supply is used, the following conditions must apply:

- External capacitance must be added on the DC bus.
- The Minimum capacitance of the Power supply: $C_{external} > \text{"Drive's Rated Current"} * 20\mu F$
- The VL- to PR is connected internally. It is not necessary to connect to the Integration Board.



8.2. Feedback Connector FDB

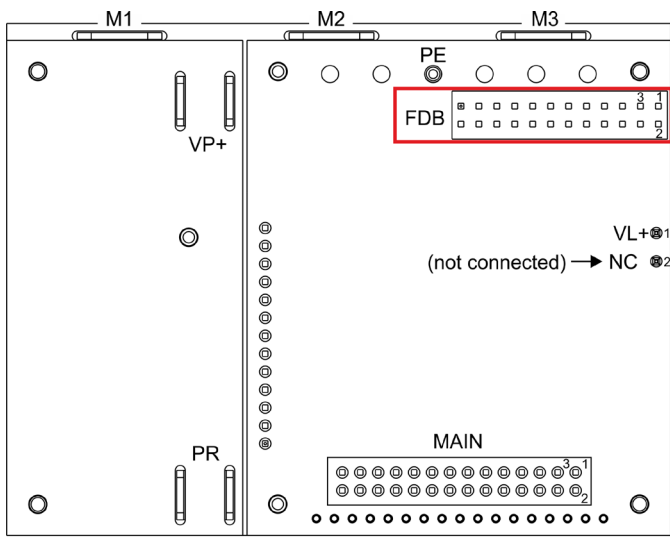

G-TWI_ADV-008B-E

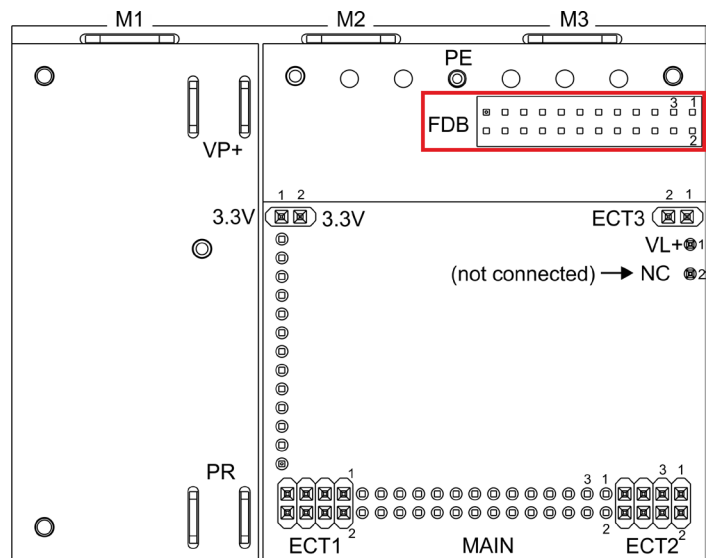

G-TWI_ADV-008B-D

FDB Connector in the CAN option

FDB Connector in the EtherCAT option

Feedback A/B/C, Digital Halls – see Section 9.2 in the manual: MAN-G-Board Level Modules Hardware Manual.

Pin FDB	Signal	Function
1	PortA_ENC_A+ /ABS_CLK+	Port A- channel A/ Absolute encoder clock+
2	PortB_ENC_A-/SIN-	Port B - channel A complement
3	PortA_ENC_A-/ABS_CLK-	Port A- channel A complement / Absolute encoder clock-
4	PortB_ENC_A+/SIN+	Port B - channel A
5	PortA_ENC_B+/ABS_DATA+	Port A - channel B/ Absolute encoder Data+
6	PortB_ENC_B-/COS-	Port B - channel B complement
7	PortA_ENC_B-/ABS_DATA-	Port A - channel B complement / Absolute encoder Data-
8	PortB_ENC_B+/COS+	Port B - channel B
9	PortA_ENC_INDEX+	Port A – index
10	PortB_ENC_INDEX-/ANALOG_I-	Port B – index complement
	RESOLVER_OUT-	Vref complement
11	PortA_ENC_INDEX-	Port A - index complement
12	PortB_ENC_INDEX+/ANALOG_I+	Port B – index
	RESOLVER_OUT+	Vref



Pin FDB	Signal	Function
13	HA	Hall sensor A input
14	PortC_ENCO_A-	Port C- channel A complement output
15	HB	Hall sensor B input
16	PortC_ENCO_A+	Port C- channel A output
17	HC	Hall sensor C input
18	PortC_ENCO_B-	Port C - channel B complement output
19	+5VE	Encoder +5 V supply @ Limit 250 mA
20	PortC_ENCO_B+	Port C - channel B output
21	COMRET	Common return
22	PortC_ENCO_INDEX-	Port C - index complement output
23	COMRET	Common return
24	PortC_ENCO_INDEX+	Port C - index output

Table 5: Connector FDB – Feedback



8.2.1. Port A

Refer to section 10.3 in the MAN-G-Board Level Modules Hardware Manual for further details of the Port A connections.

8.2.1.1. Incremental Encoder

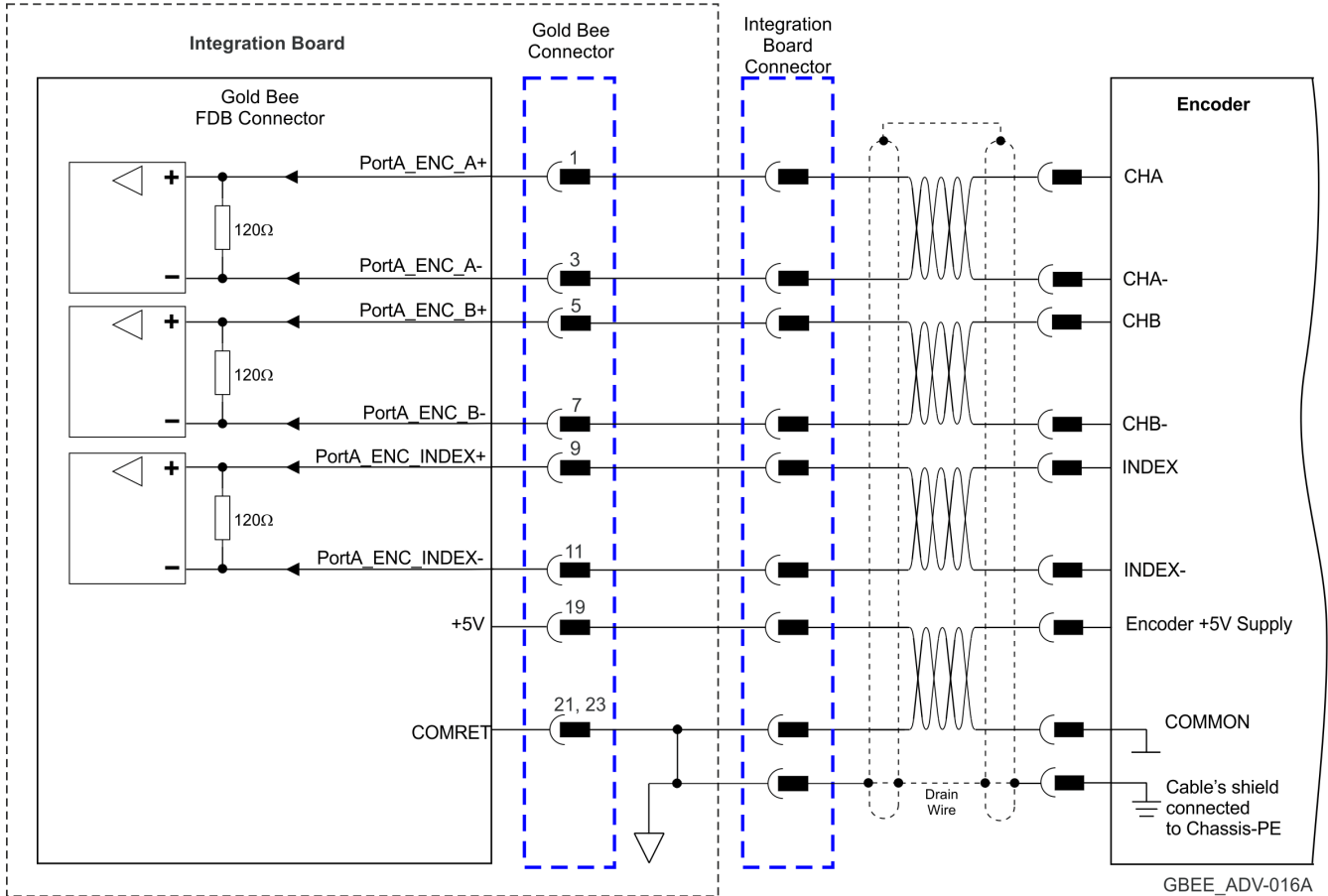

Figure 11: Port A Incremental Encoder Input – Recommended Connection Diagram



8.2.1.2. Absolute Serial Encoder

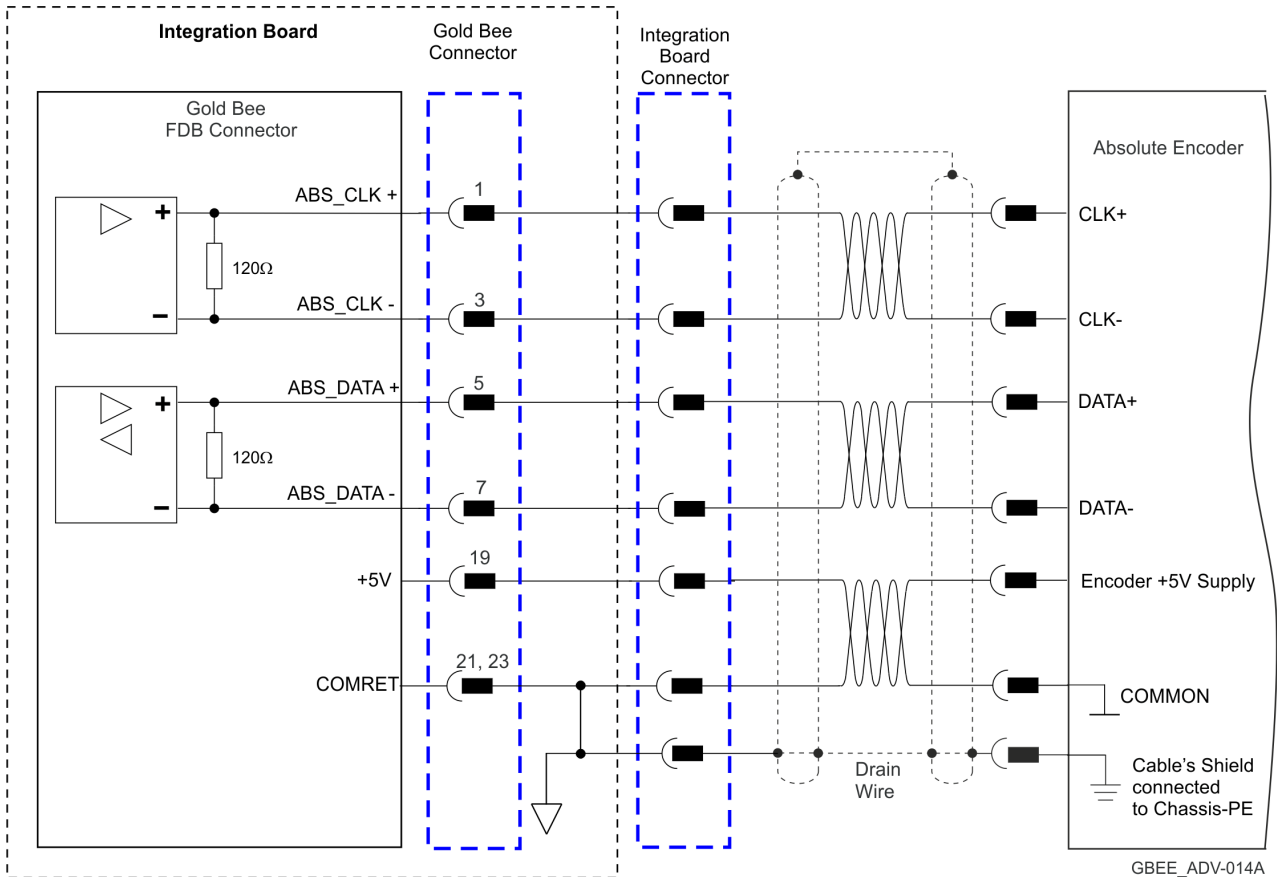

Figure 12: Absolute Serial Encoder – Recommended Connection Diagram for Sensors Supporting Data/Clock (e.g., Biss / SSI / EnDAT, etc.)

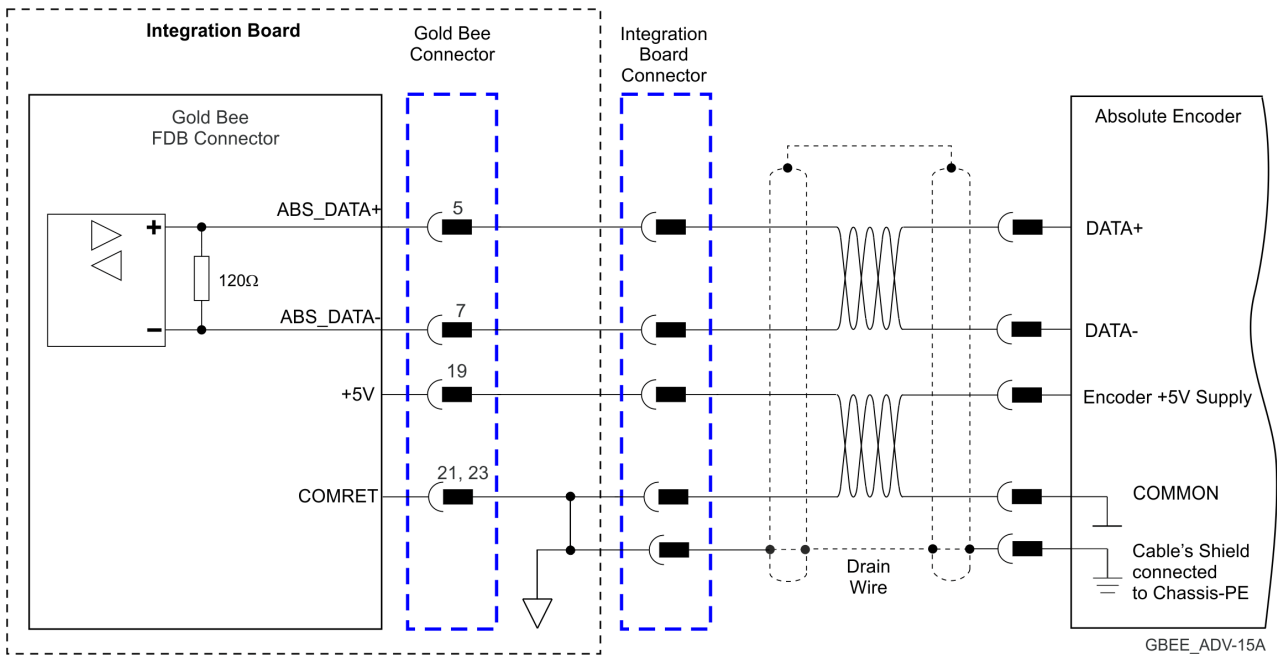

Figure 13: Absolute Serial Encoder – Recommended Connection Diagram for Sensors Supporting Data Line Only (NRZ types, e.g., Panasonic / Mitutoyo / etc.)



8.2.1.3. Hall Sensors

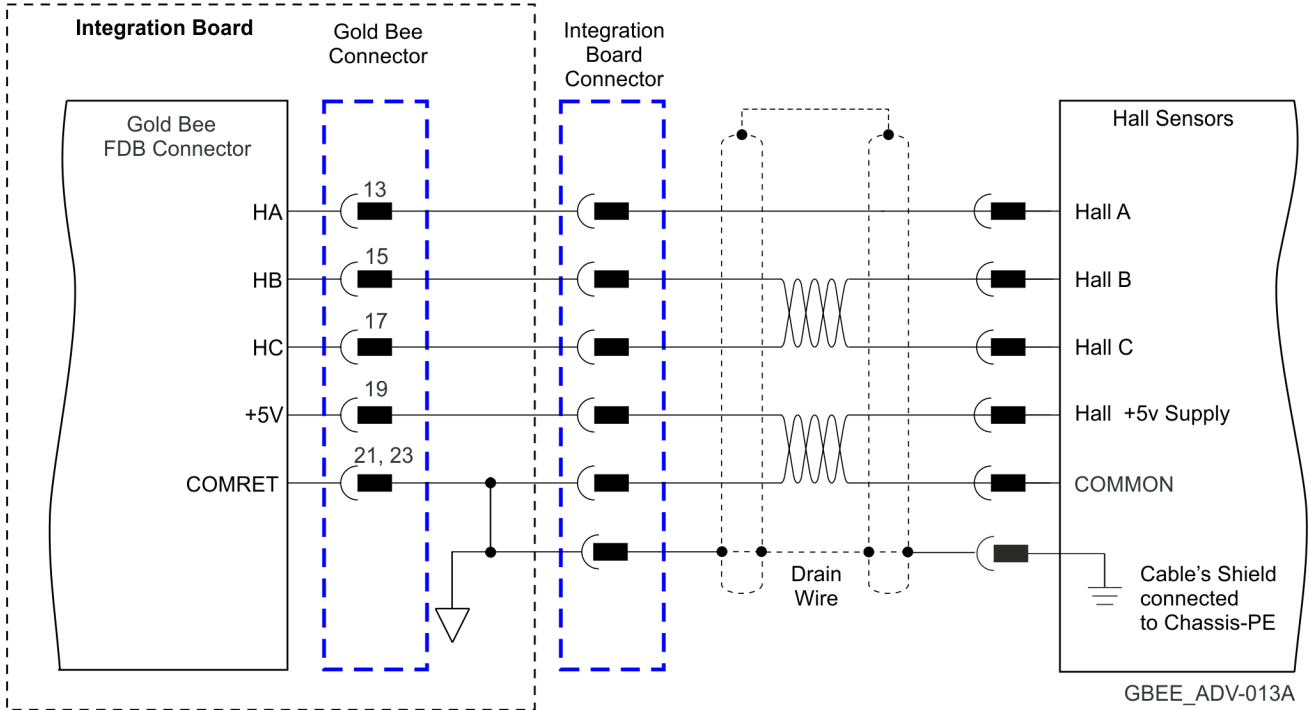

Figure 14: Hall Sensors Connection Diagram



8.2.2. Port B

Refer to section 10.4 in the MAN-G-Board Level Modules Hardware Manual for further details of the Port B connections.

8.2.2.1. Incremental Encoder

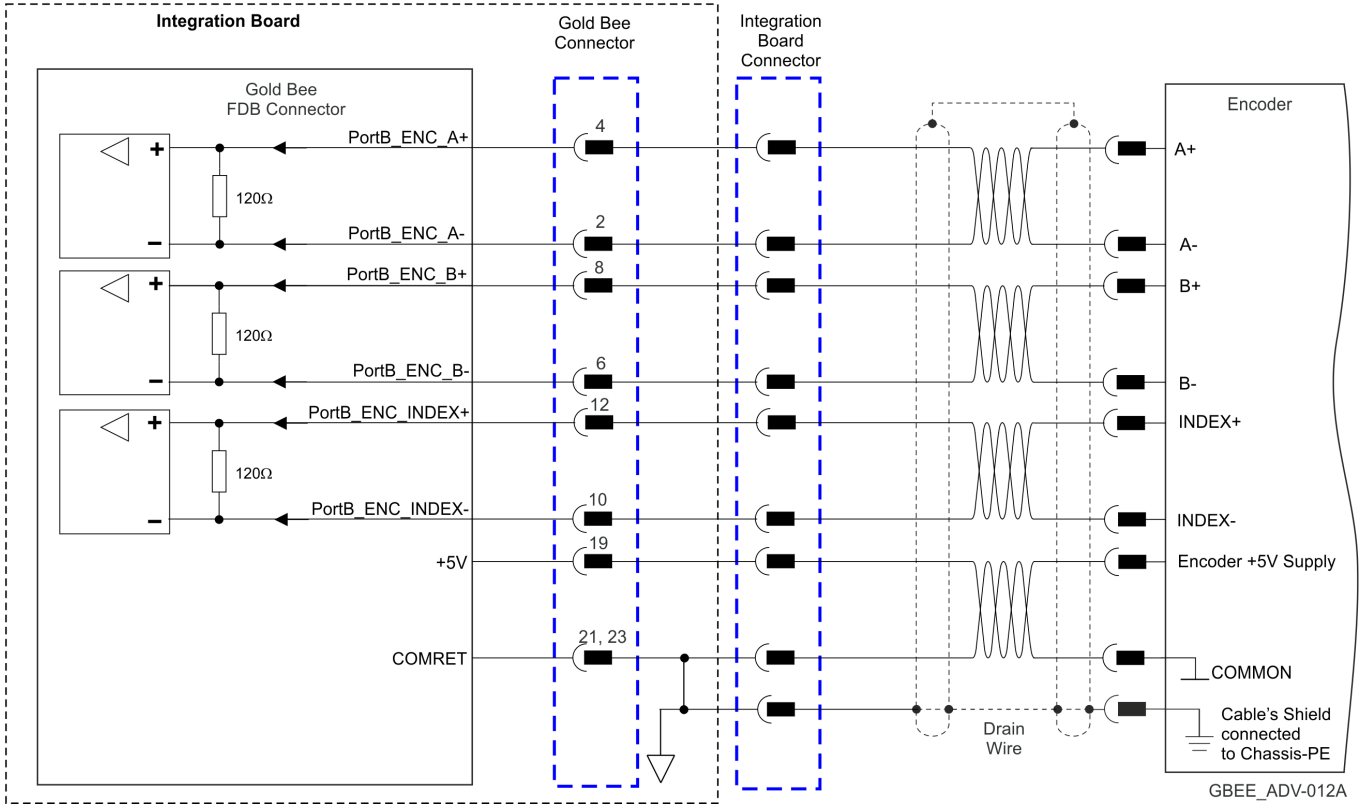

Figure 15: Port B Incremental Encoder Input – Recommended Connection Diagram



8.2.2.2. Interpolated Analog Encoder

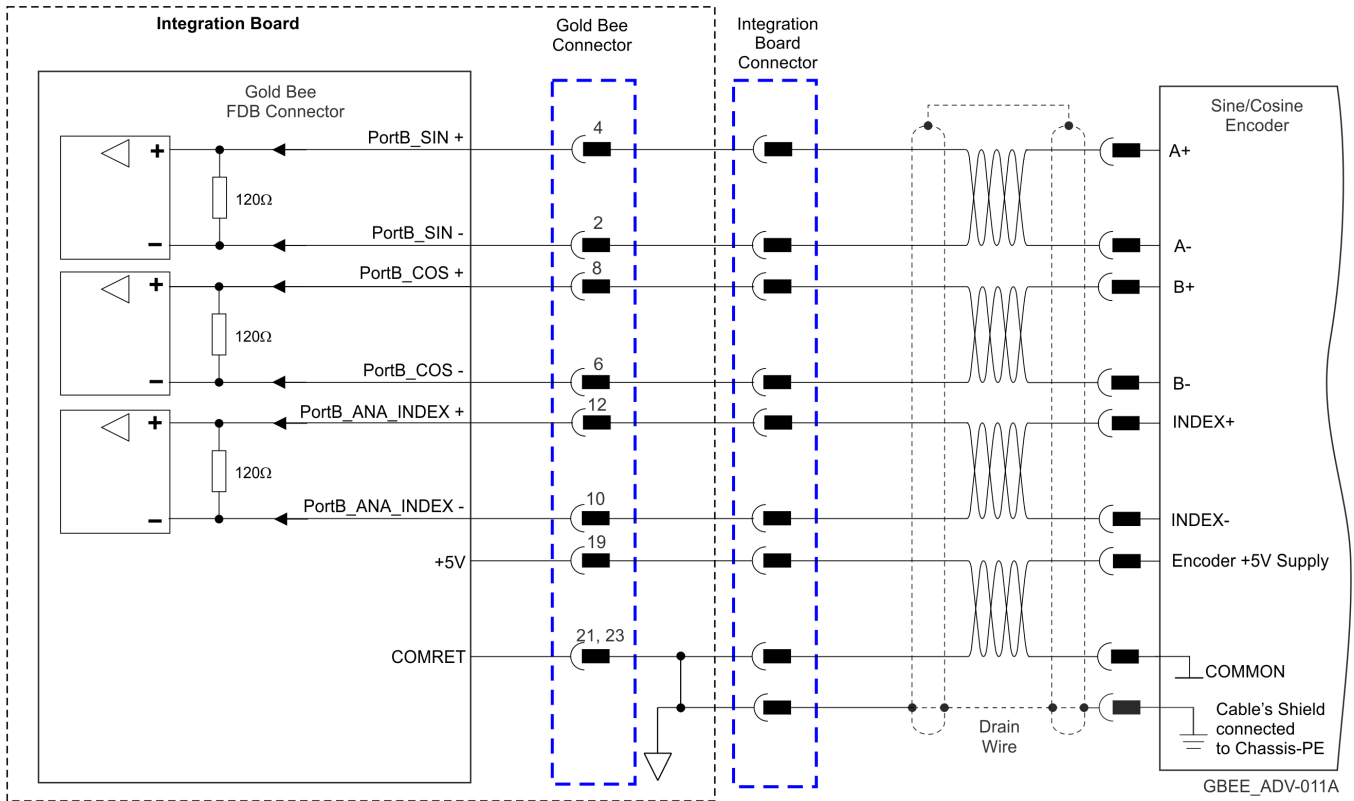

Figure 16: Port B - Interpolated Analog Encoder Connection Diagram



8.2.2.3. Resolver

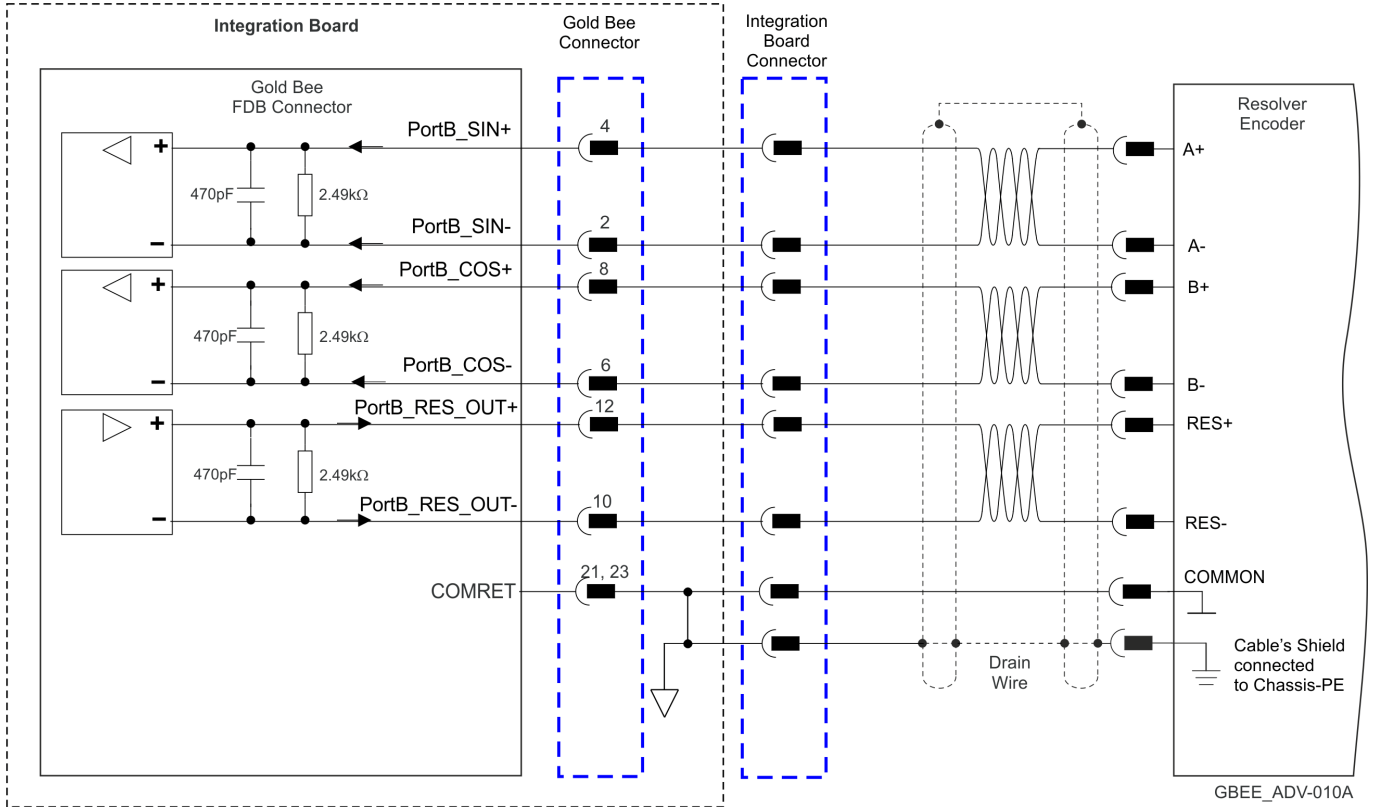

Figure 17: Port B – Resolver Connection Diagram



8.2.3. Port C – Emulated Encoder Output (FDB)

See Section 10.5 in the manual: MAN-G-Board Level Modules Hardware Manual for further details of Port C.

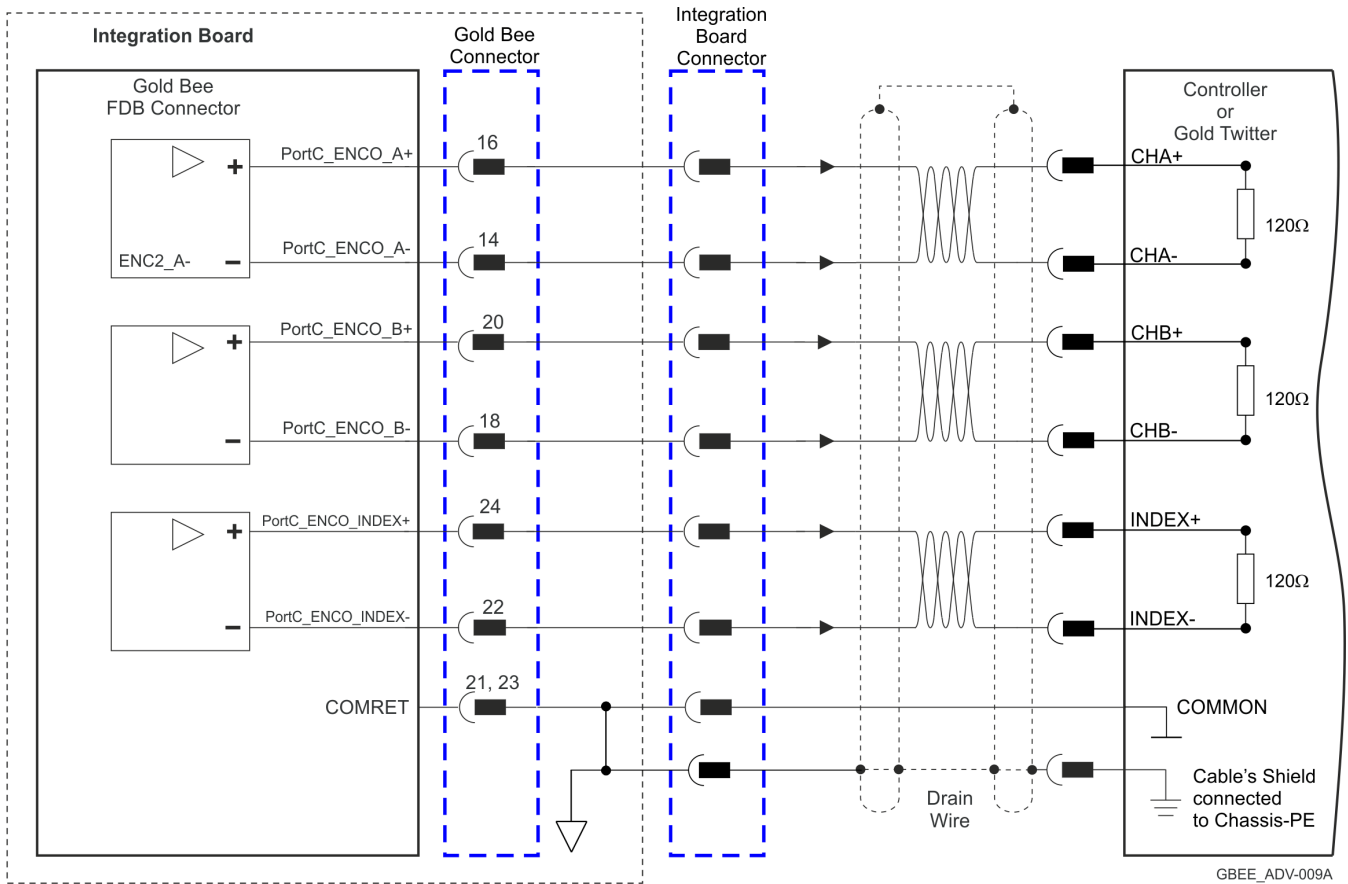
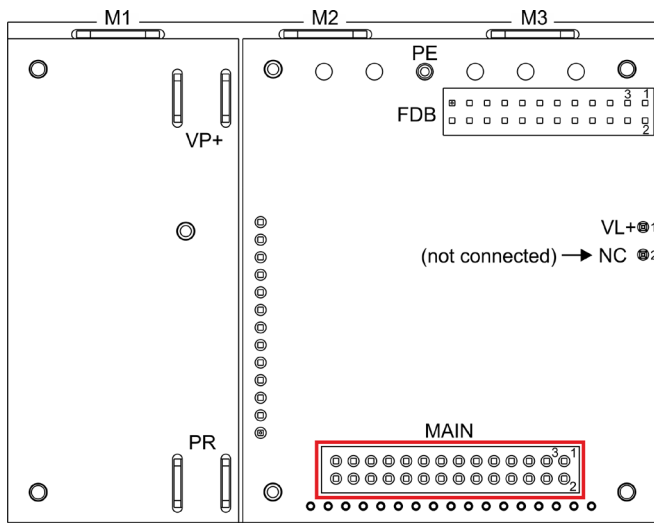

Figure 18: Emulated Encoder Differential Output – Recommended Connection Diagram



8.3. Main Connector (MAIN)



GBEE_ADV-108A-G

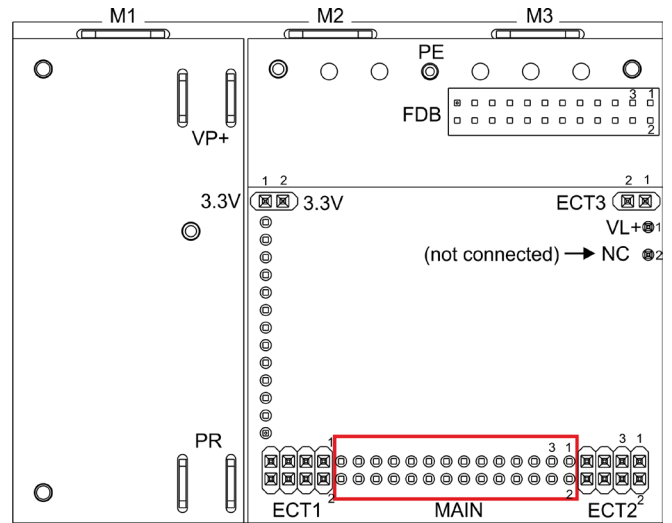

G-TWI_ADV-008B-F

MAIN Connector in the CAN option

MAIN Connector in the EtherCAT option

Pin (MAIN)	Signal	Function
1	CAN Version: CANH	CAN Version: CAN_H BUS Line(dominant high)
	ECAT Version: LED_ET_ERR	ECT Version: EtherCAT status LED Error
2	CAN Version: CANL	CAN Version: CAN_L BUS Line(dominant low)
	ECAT Version: LED_ET_RUN	ECT Version: EtherCAT status LED Run
3	RS232_TX_S	Standard RS232 transmit
4	RS232_RX_S	Standard RS232 receive
5	RS232_TX /SB_IN	There are two options for this pin: Option 1: TTL RS232 transmit (Default) Option 2: Serial Bus IN for extended I/O (refer to MAN-G-Board Level Modules Hardware manual) This option is only available for EtherCAT
6	RS232_RX /SB_OUT	There are two options for this pin: Option 1: TTL RS232 receive (default) Option 2: Serial Bus output for extended I/O (refer to MAN-G-Board Level Modules Hardware manual) This option is only available for EtherCAT
7	COMRET	Common return



Pin (MAIN)	Signal	Function
8	COMRET	Common return
9	ANALOG1+	Analog input 1
10	ANALOG1-	Analog input 1 complement
11	ANALOG_IN2	Analog input 2
12	STO1	STO 1 input, opto isolated from control (COMRET)
13	STO_RET	STO signal return. The two digital STO inputs are optically isolated from the other parts of the drive, and share one return line.
14	STO2	STO 2 input
15	LED1	Bi-color indication output 1 (Cathode) Internal Resistor 1K Ω
16	LED2	Bi-color indication output 2 (Cathode) Internal Resistor 1K Ω
17	OUT4	Programmable output 4 (connected to COMRET) (3.3V logic level)
18	OUT2	Programmable output 2 (connected to COMRET) (5V logic level)
19	OUT3	Programmable output 3 (connected to COMRET) (3.3V logic level)
20	OUT1	Programmable output 1 (connected to COMRET) (5V logic level)
21	COMRET	Common return
22	COMRET	Common return
23	IN6	Programmable digital input 6 (connected to COMRET) (5V logic level)
24	IN5	Programmable digital input 5 (connected to COMRET) (5V logic level)
25	IN4	Programmable digital input (connected to COMRET) (5V logic level)
26	IN3	Programmable digital input 3 (connected to COMRET) (5V logic level)
27	IN2	Programmable digital input 2 (connected to COMRET) (5V logic level)
28	IN1	Programmable digital input 1 (connected to COMRET) (5V logic level)

Table 6: Connector MAIN – I/O, STO, Analog, LEDs



8.3.1. LEDs

For full details on the LEDs, see Chapter 7, and section 12.2.1 in the in the MAN-G-Board Level Modules Hardware manual for full details.

8.3.2. STO (safety)

For full details on STO, see Chapter 9 in the in the MAN-G-Board Level Modules Hardware manual for full details.



8.3.3. Digital Inputs

The following table describes the electrical specification of the inputs IN1 and IN6:

Feature	Details
Input Voltage (VIN)	0 to 6V
V _{ih} min	2.2V
V _{il} max	0.6V
R ₁ Pull-up Resistor	If VT = 3.3V, R1<3.3KΩ If VT = 5V, R1<10KΩ
Minimum pulse width	> 250 μsec
Execution time (all inputs): the time from application of voltage on input until execution is complete	0 < T < 250 μsec
High-speed inputs – 1–6 minimum pulse width, in high-speed mode	T = 5 μsec if the input functionality is set to latch/capture (index/strobe). Note: Home mode is high-speed mode and can be used for fast capture and precise homing.
Capture with differential input Port A, Port B Index	T > 0.1 μsec if the differential input functionality is set to touch probe/capture (index/strobe).

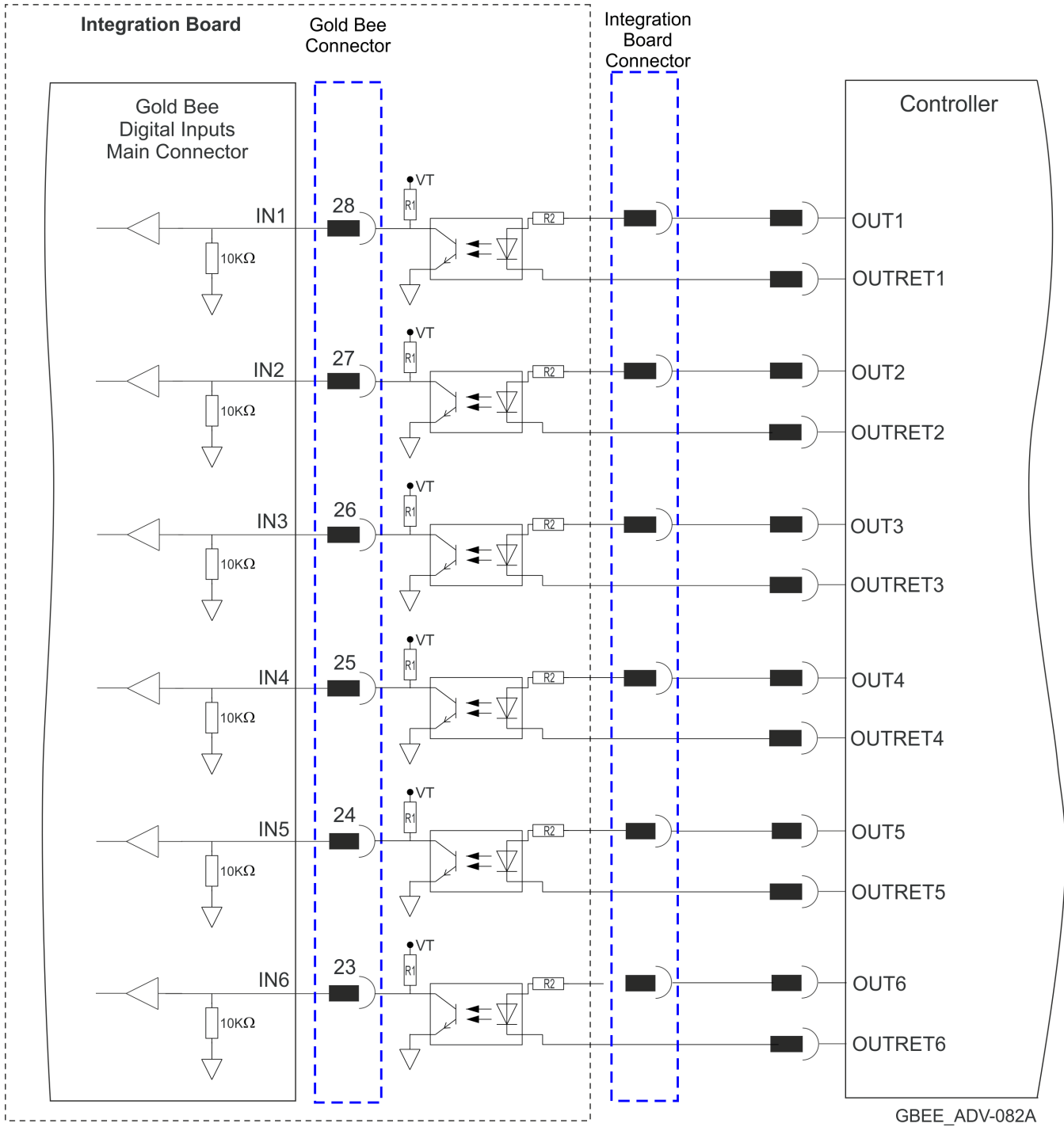

Figure 19: Digital Input 5V Logic level Mode Connection Diagram



8.3.4. Digital Outputs

There are two types of Digital outputs:

- Out1 and Out2 5V Logic
- Out3 and Out4 3.3V Logic

The following table describes the electrical specification of the outputs OUT1 and OUT2:

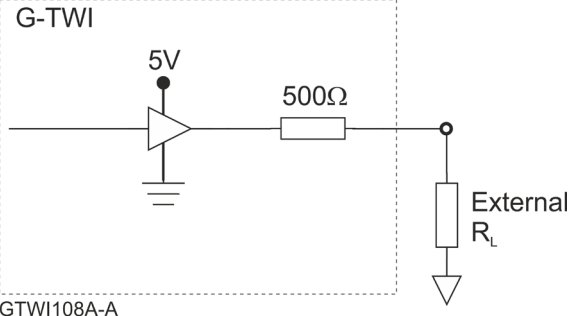
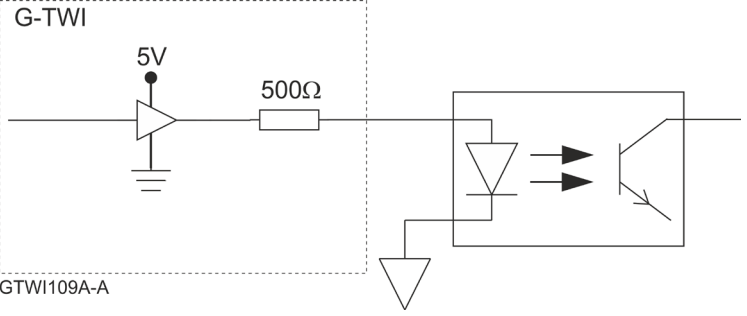
Feature	Details
Type of output	5V Logic
Output Configuration	 <p>GTWI108A-A</p>
V _{OL} max of TTL Buffer (low level)	V _{out} (Low) ≤ 0.44V @ 8mA
V _{OH} min of TTL Buffer (High level)	V _{out} (High) >4.4V @ 8mA
Output current	$I_{out(max)} = \frac{5V}{500\Omega + R_L (external)}$ <p>Where:</p> $V_{R_L(High)} = 5V - 500 * I_{out(max)}$
Example of connection to the opto-couplers	 <p>GTWI109A-A</p> <p>Where:</p> $I_{out(max)} = \frac{5V - 2.0V}{500\Omega} = 6.0mA$
T _{on} (time from low to high)	<1μsec
T _{off} (time from high to low)	<1μsec
Executable time	0 < T < 250 μsec

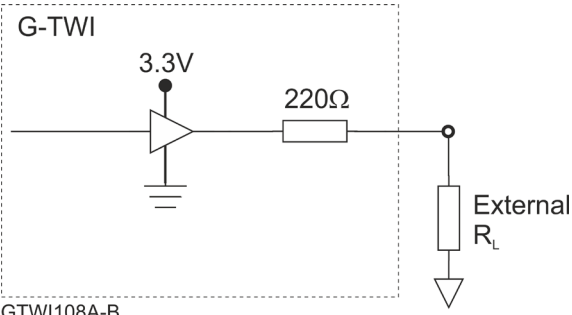
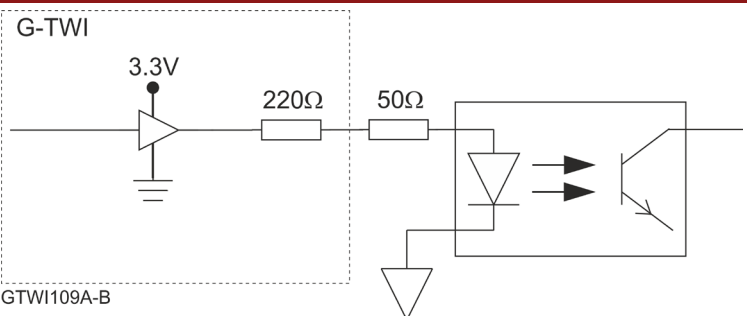

The following table describes the electrical specification of the outputs OUT3 and OUT4.

Feature	Details
Type of output	3.3V Logic
Output Configuration	<p>G-TWI</p>  <p>GTWI108A-B</p>
V _{OL} max of TTL buffer (low level)	V _{out} (On) ≤ 0.4V @ 8mA
V _{OH} min of TTL buffer (High level)	V _{out} (High) >2.9V @ 8mA
Output current	$I_{out(max)} = \frac{3.3V}{220\Omega + R_L (external)}$ <p>Where:</p> $V_{R_L(High)} = 3.3V - 220 * I_{out(max)}$
Example of connection to the opto-couplers	<p>G-TWI</p>  <p>GTWI109A-B</p> <p>Where:</p> $I_{out(max)} = \frac{3.3V - 2.0V}{220\Omega + 50\Omega} = 4.8 mA$
T _{on} (time from low to high)	<1usec
T _{off} (time from high to low)	<1usec
Executable time	0 < T < 250 μsec

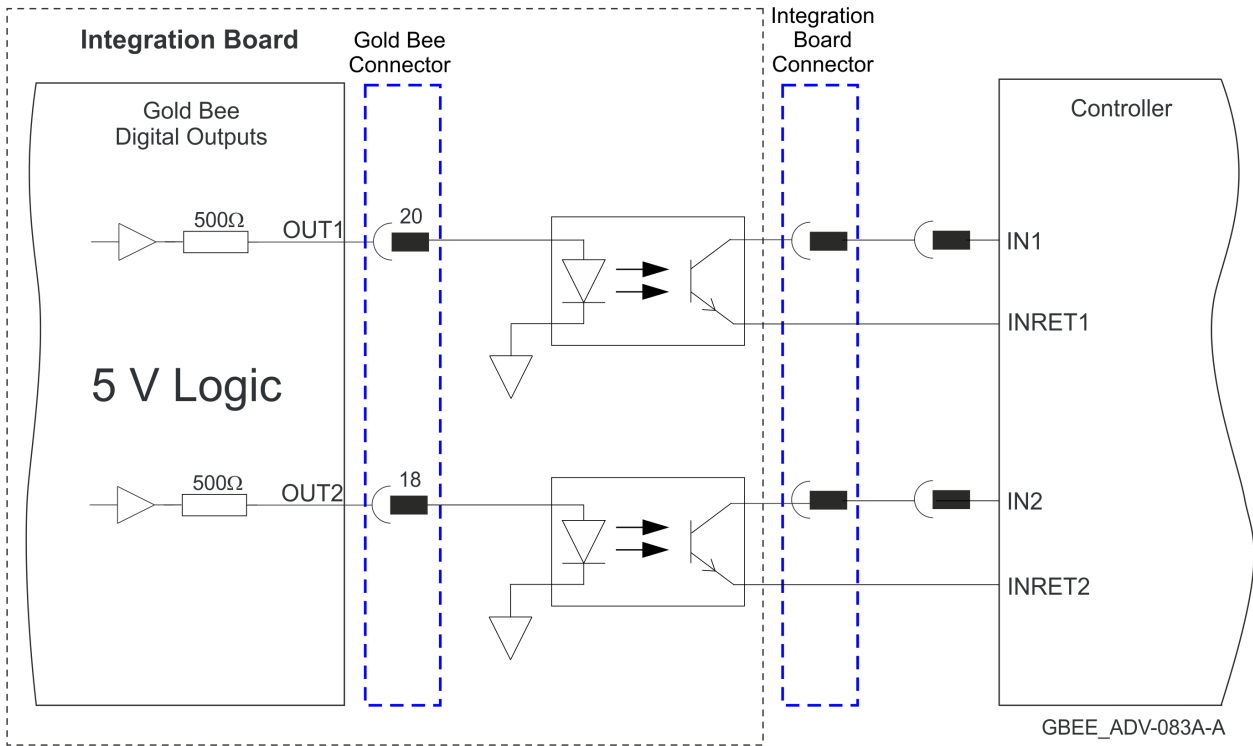

Figure 20: Digital Output 5V Logic Mode Connection Diagram

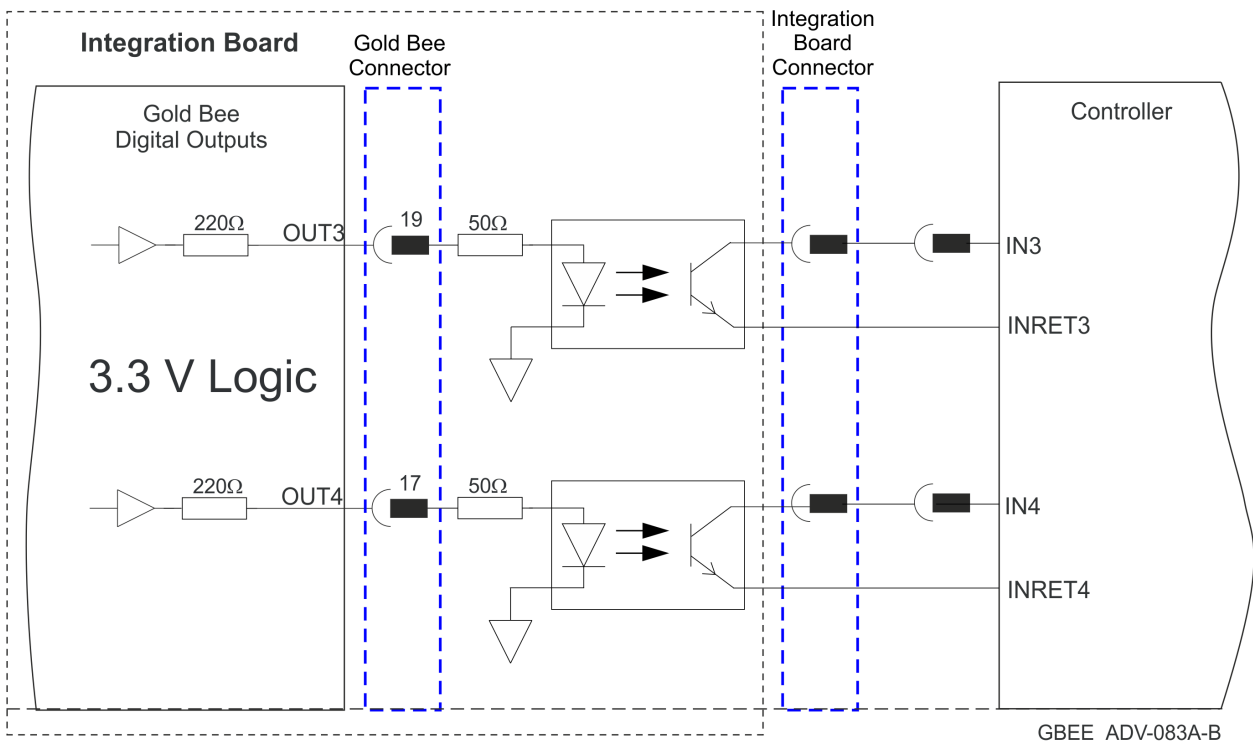

Figure 21: Digital Output 3.3V Logic Mode Connection Diagram



8.3.5. STO (Safe Torque Off)

For full details on STO, see Chapter 9 in the MAN-G-Board Level Modules Hardware manual.

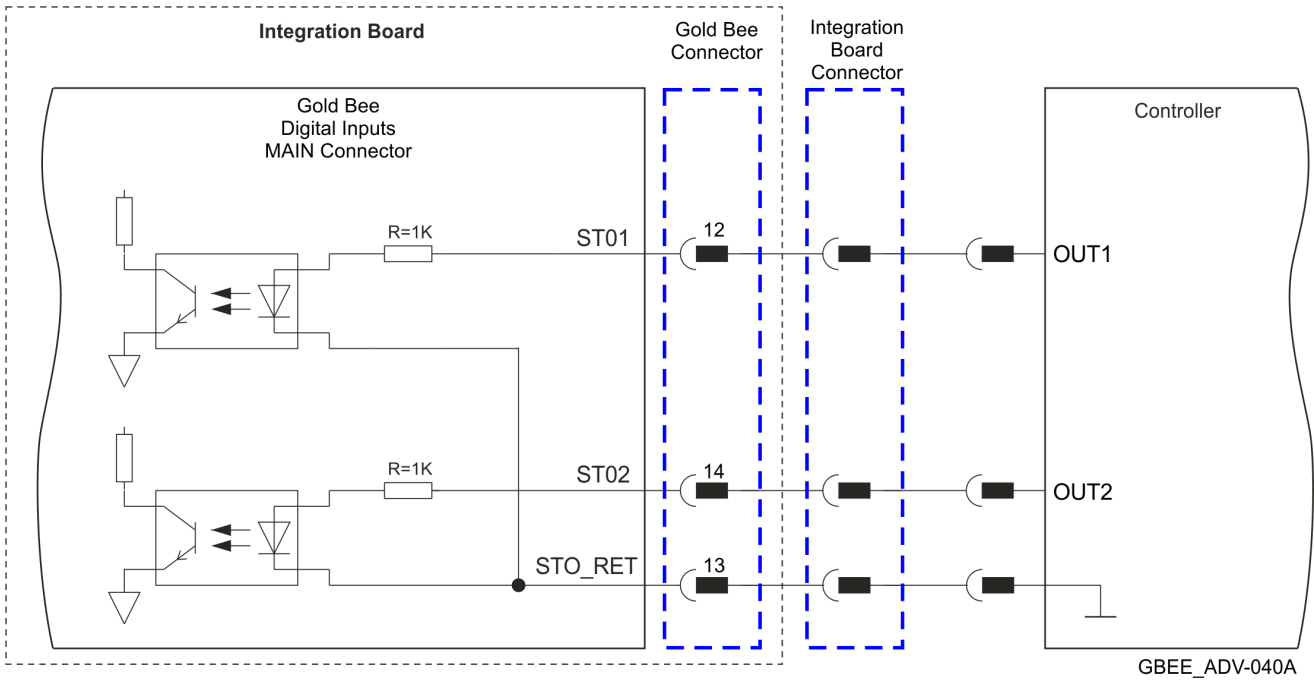

Figure 22: STO Input Connection – 5V Logic Level

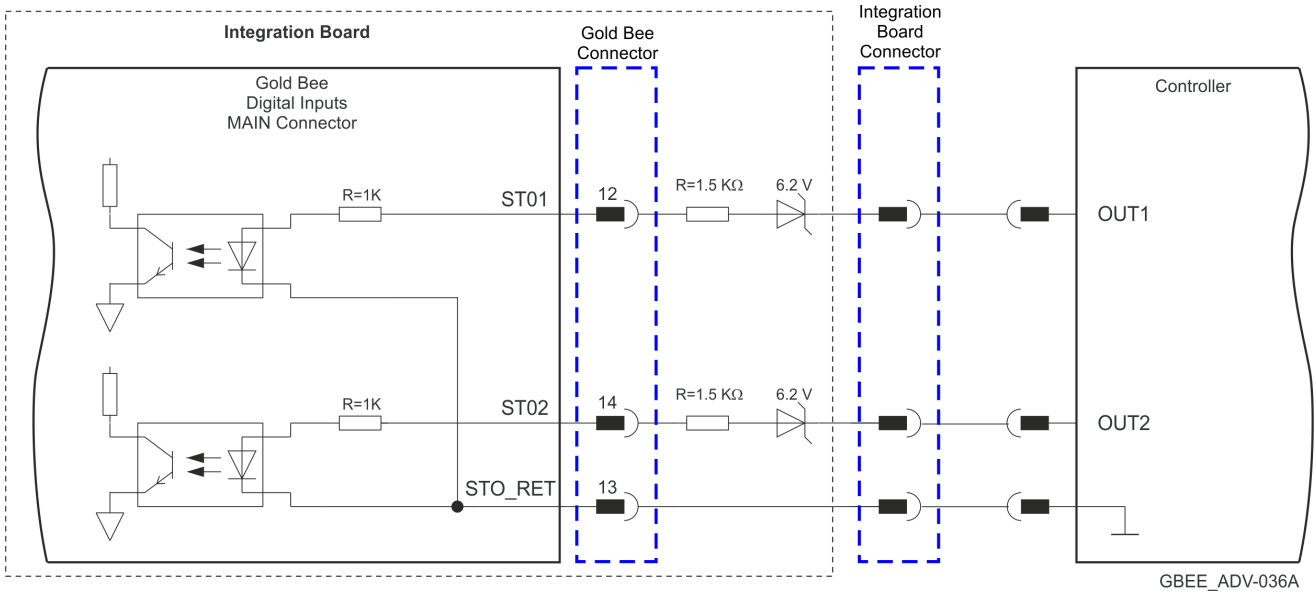

Figure 23: STO Input Connection – PLC (24V Logic)



8.3.6. Analog Input

For full details on Analog Inputs, see section 11.3 in the MAN-G-Board Level Modules Hardware manual.

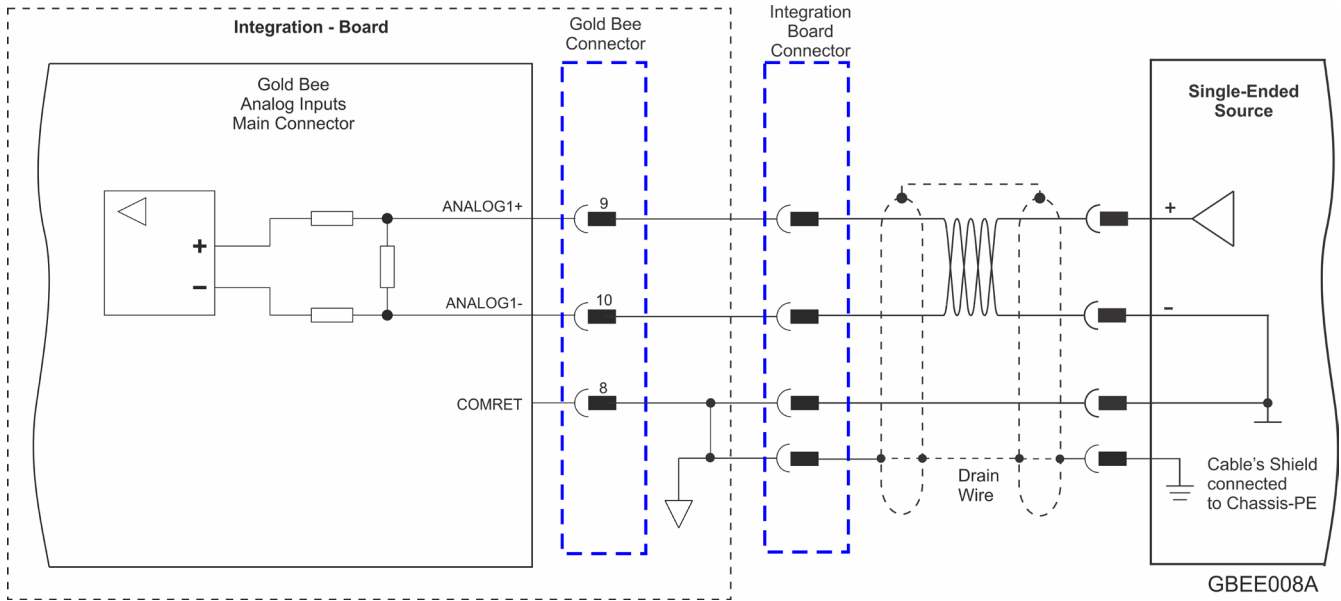

Figure 24: Analog Input



8.3.7. CAN Option

For full details on CANopen communication, see section 14.3 in the MAN-G-Board Level Modules Hardware manual.

8.3.7.1. Interface

The PCB-Mounted Module includes the CAN transceiver and mode choke. Therefore it is required to add a CAN Bus Protector for ESD and other harmful transient voltage events.

The following signals describe how to connect CAN to the external connector.

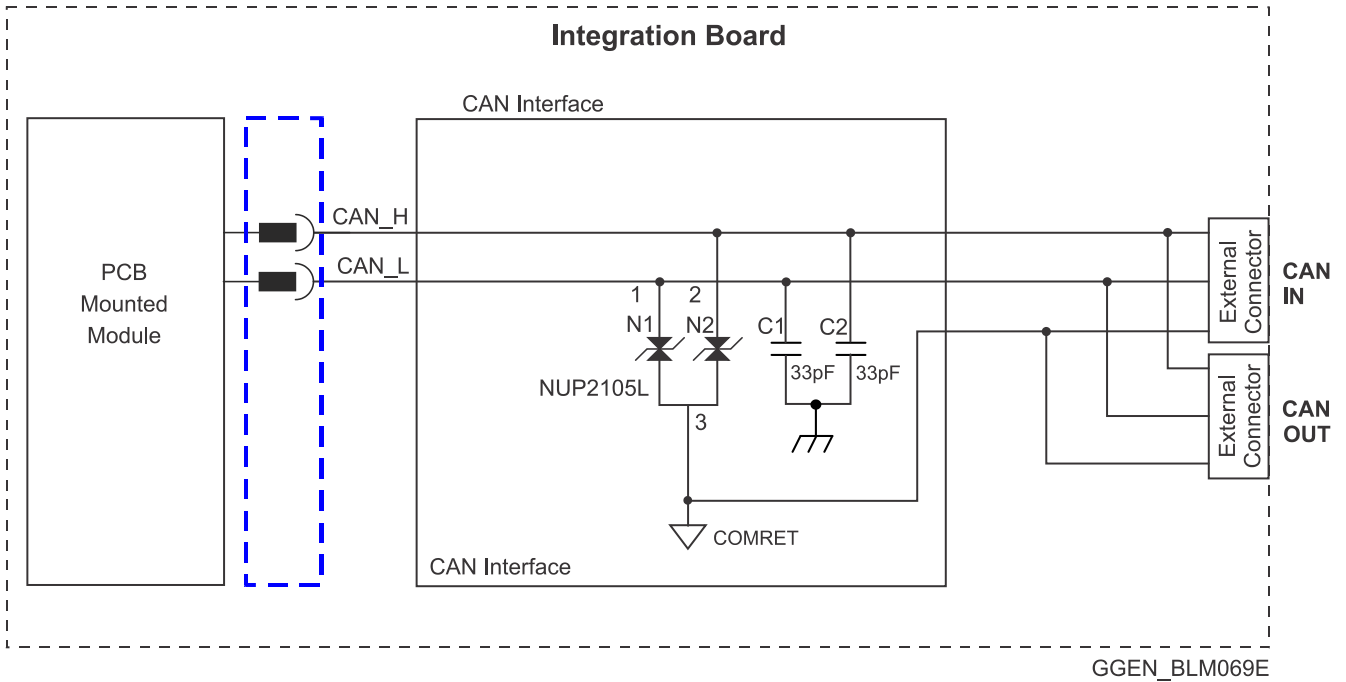

Figure 25: CAN Interface

The following are examples of the components described in Figure 25.

Interface Components	Part	P/N
33PF/50V,NPO,10%	AVX	06035A330JAT1A
DUAL BIDIRECTIONAL VOLTAGE SUPPRESSOR,NUP2105L	ON SEMIC	NUP2105LT1G



8.3.7.2. CAN Layout

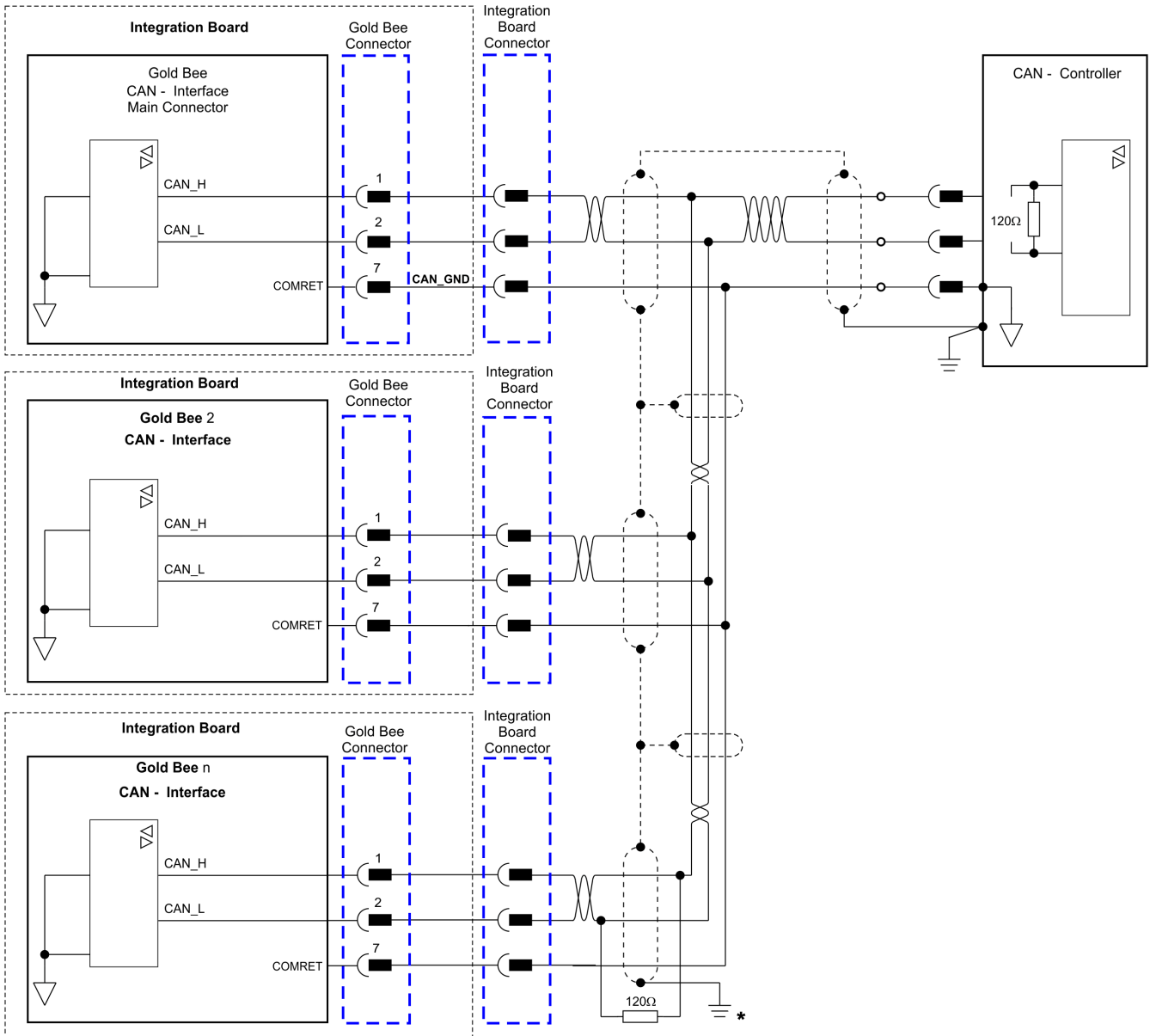

GBEE_ADV-018A

* Note: If cable is long (>5M) it is recommended to ground at both ends

Figure 26: CAN Network Diagram



Caution: When installing CAN communication, ensure that each servo drive is allocated a unique ID. Otherwise, the CAN network may “hang”.



8.3.8. RS232

There are two types of RS232: Standard RS232 and RS232 TTL Level.

Figure 27 describes the Standard RS232 connection diagram.

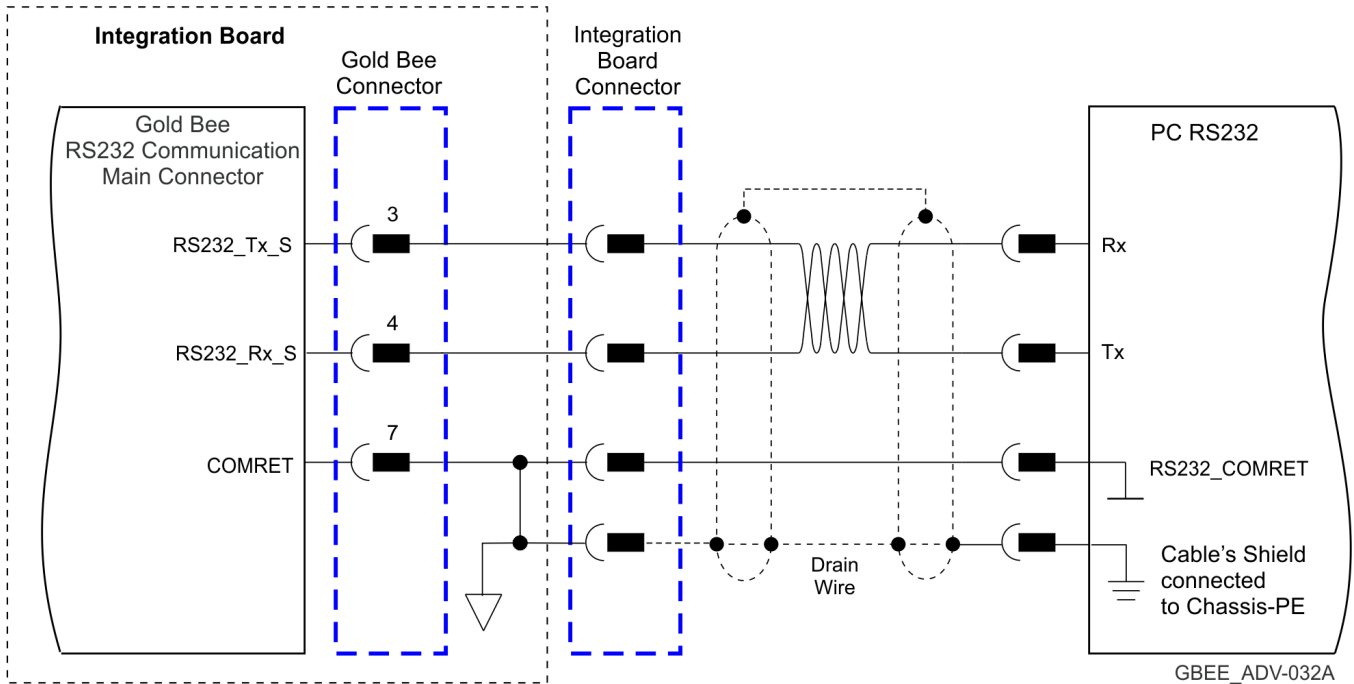

Figure 27: RS232 Connection Diagram

For full details on RS232 TTL Level communication, see section 12.5.1 in the MAN-G-Board Level Modules Hardware manual.



The RS232 TTL Level will be used in order to connect Differential RS232 (RS422).

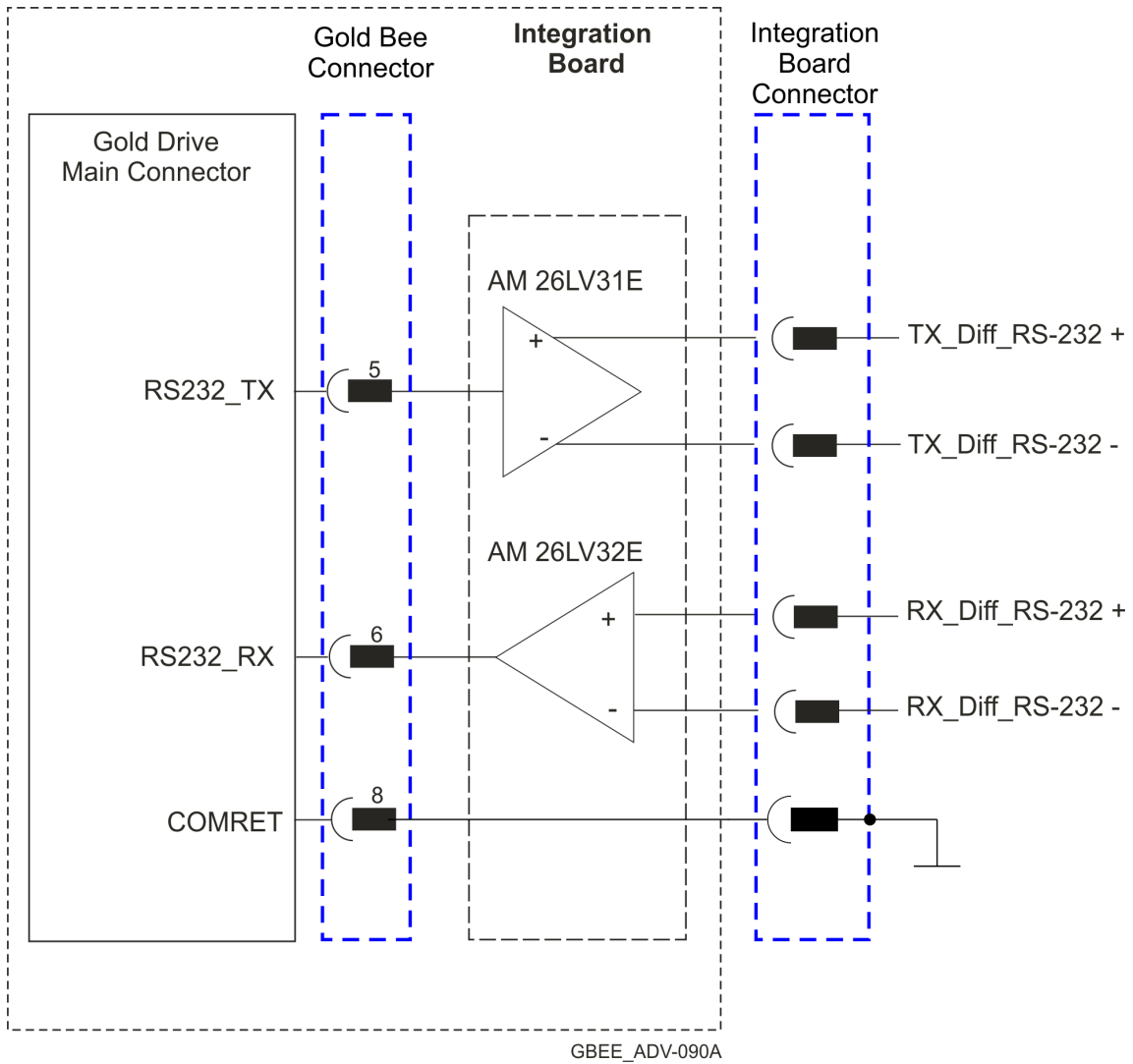
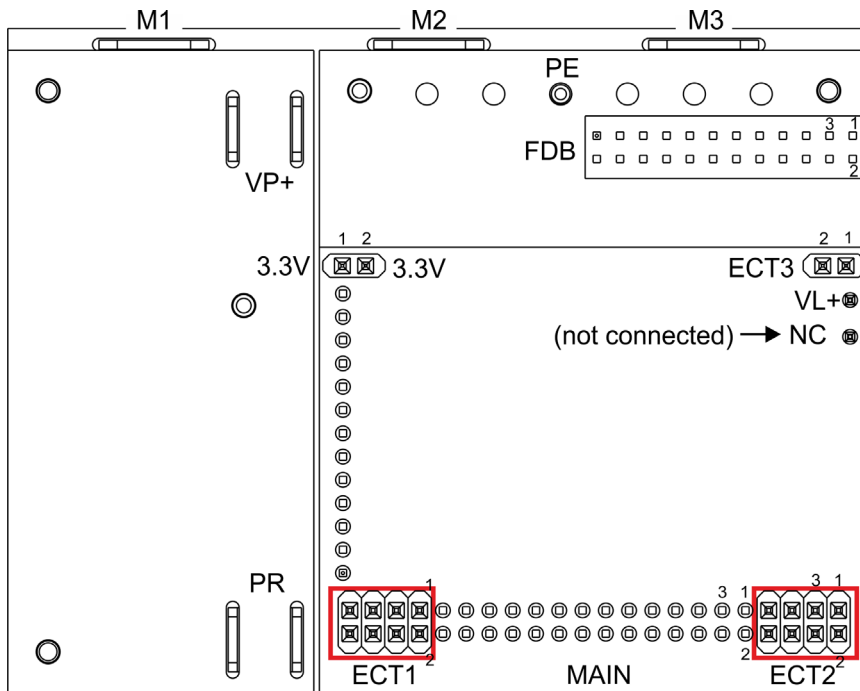

Figure 28: Differential RS232 (RS422) Connection Diagram



8.4. EtherCAT Module



For full details on EtherCAT communication, see Section 12.2 in the in the MAN-G-Board Level Modules Hardware manual.

G-TWI_ADV-008B-H

8.4.1. EtherCAT Module Connectors

8.4.1.1. ECT2 connector

Pin (ECT2)	Signal	Function
1	USB_VBUS	USB VBUS 5V Detector
2	USBD+	USB_P line
3	COMRET	USB communication return
4	USBD-	USB_N line
5	PHY_IN_LINK_ACT	Indicates EtherCAT IN/Ethernet LINK input
6	PHY_OUT_LINK_ACT	Indicates EtherCAT OUT LINK
7	PHY_IN_SPEED	Indicates EtherCAT IN/Ethernet Speed input
8	PHY_OUT_SPEED	Indicates EtherCAT OUT Speed

Table 7: Connector ECT2

**8.4.1.2. ECT1 connector**

Pin (ECT1)	Signal	Function
1	PHY_OUT_RX+	EtherCAT OUT RX+ Line
2	PHY_OUT_TX+	EtherCAT OUT TX+ Line
3	PHY_OUT_RX-	EtherCAT OUT RX- Line
4	PHY_OUT_TX-	EtherCAT OUT TX- Line
5	PHY_IN_RX+	EtherCAT IN/Ethernet RX+ Line
6	PHY_IN_TX+	EtherCAT IN/Ethernet TX+ Line
7	PHY_IN_RX-	EtherCAT IN/ Ethernet RX- Line
8	PHY_IN_TX-	EtherCAT IN/Ethernet TX- Line

Table 8: Connector ECT1

Note: EtherCAT IN port can be configured to an Ethernet Port.

8.4.1.3. ECT3 Connector

Pin (ECT3)	Signal	Function
1	SB_Load	Serial Bus Load for extended IO (refer to the MAN-G-Panel Mounted Drives Hardware Manual)
2	SB_Clock	Serial Bus_Clock (9.375Mhz) for extended IO (refer to the MAN-G-Panel Mounted Drives Hardware Manual)

Table 9: Connector ECT3**8.4.1.4. 3.3V Connector**

Pin	Signal	Function
1	3.3V	3.3 V supply voltage for EtherCAT LEDs
2	3.3V	3.3 V supply voltage for EtherCAT LEDs

Table 10: 3.3V Connector



8.4.2. EtherCAT Communication

This section only describes the EtherCAT communication, and the pinout drawing of the connector.



When the EtherCAT is connected and the FoE is in operation, the USB cable connection must be disconnected.

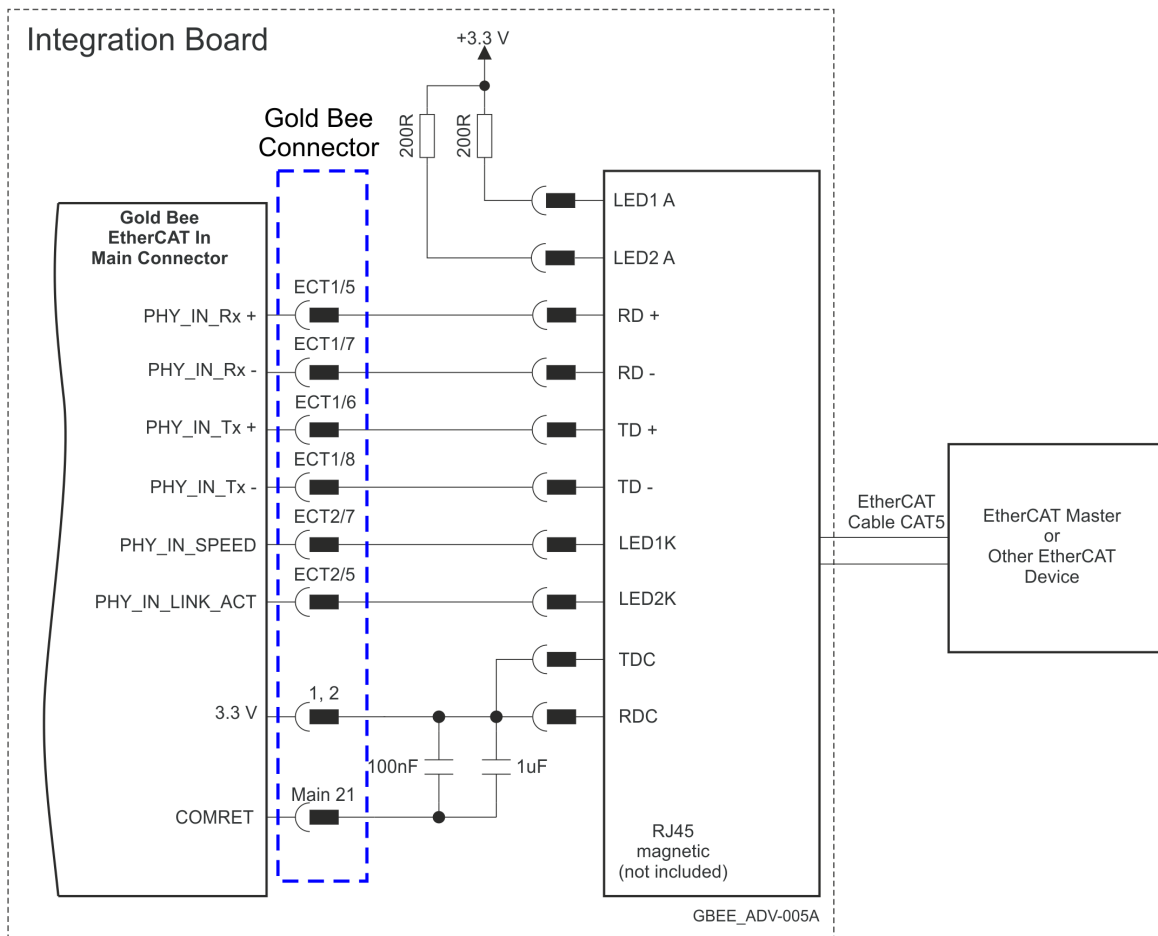
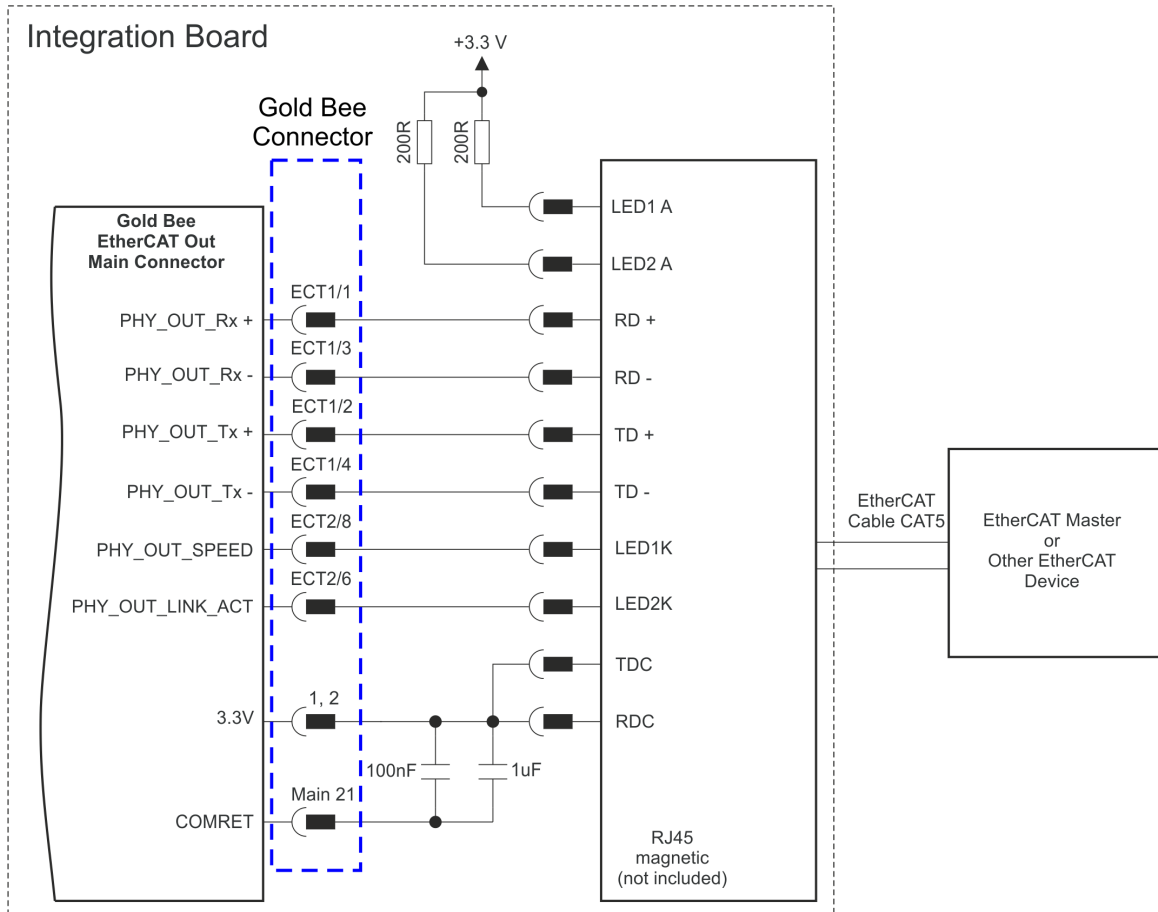

Figure 29: EtherCAT Connection Schematic Diagram



8.4.3. USB 2.0 Communication

For full details on USB communication, see section 12.1 in the MAN-G-Board Level Modules Hardware manual.

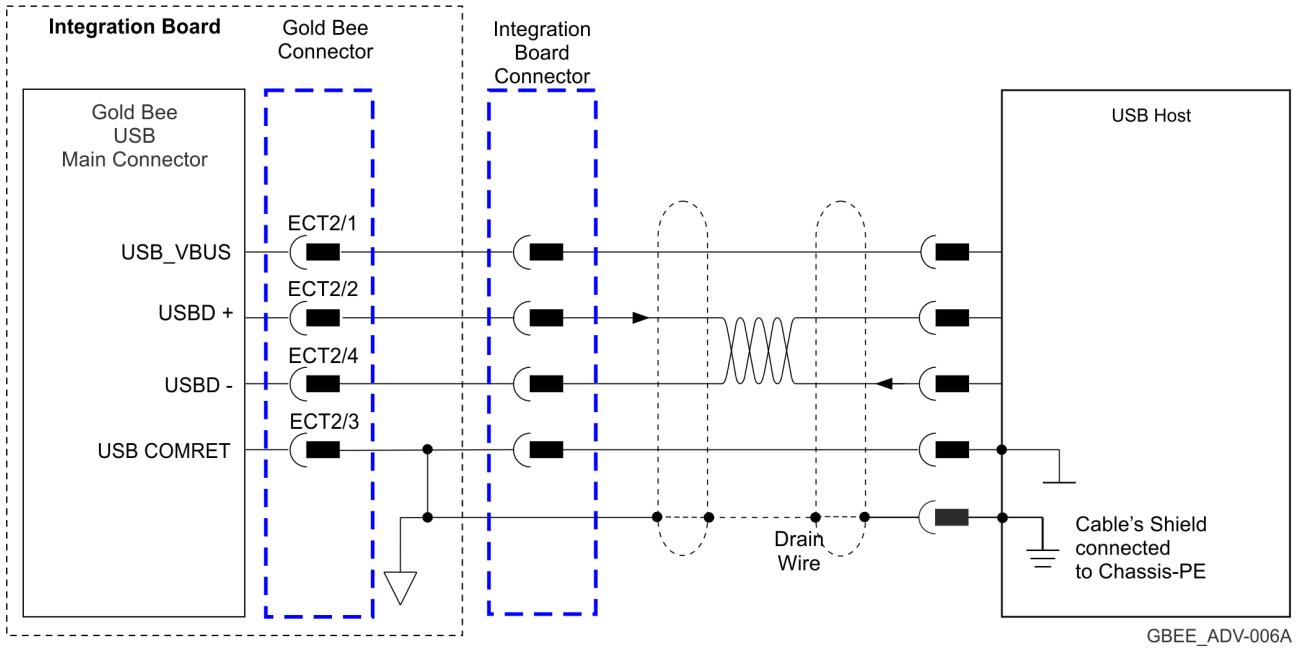

Figure 30: USB Network Diagram



Chapter 9: Powering Up

After the Gold Bee is connected to its device, it is ready to be powered up.



Caution:

Before applying power, ensure that the DC supply is within the specified range and that the proper plus-minus connections are in order.

9.1. Initializing the System

After the Gold Bee has been connected and mounted, the system must be set up and initialized. This is accomplished using the *EASII*, Elmo's Windows-based software application. Install the application and then perform setup and initialization according to the directions in the *EASII User Manual*.



9.2. Heat Dissipation

The best way to dissipate heat from the Gold Bee is to mount it so that its heat-sink is attached to the machine chassis. If mounted with its heat-sink suspended, then for best results mount the servo drive faced upwards and leave approximately 10 mm of space between the Gold Bee's heat-sink and any other assembly.

9.2.1. Heat Dissipation Data

Heat Dissipation is shown graphically below.

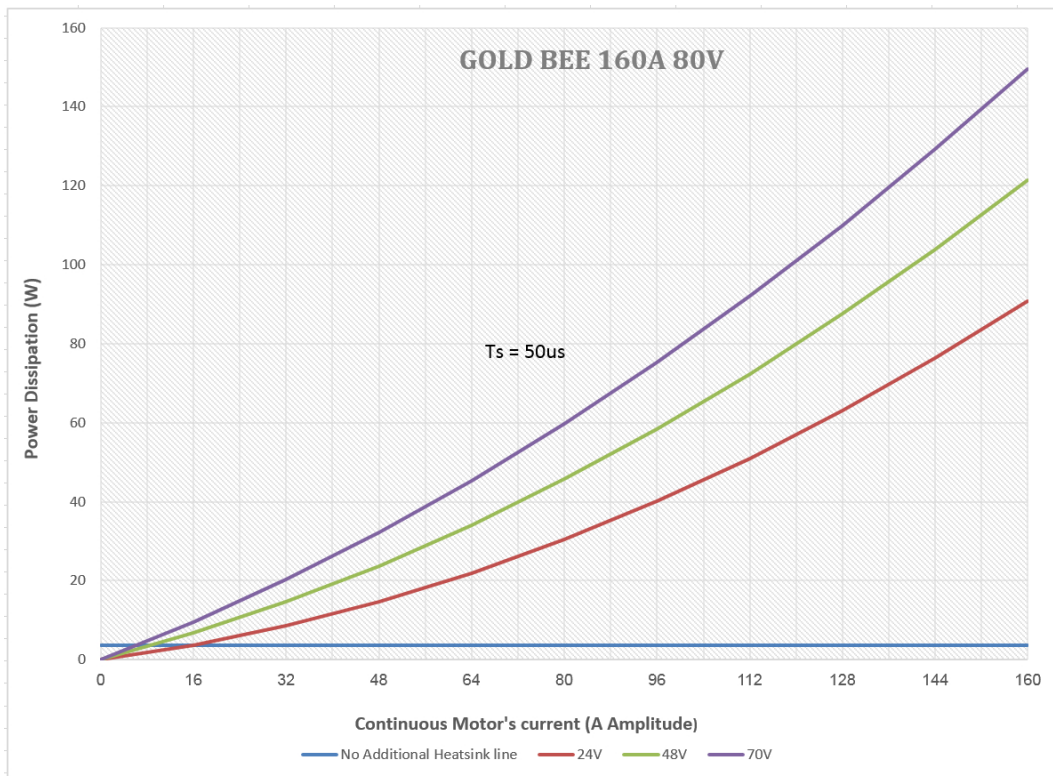
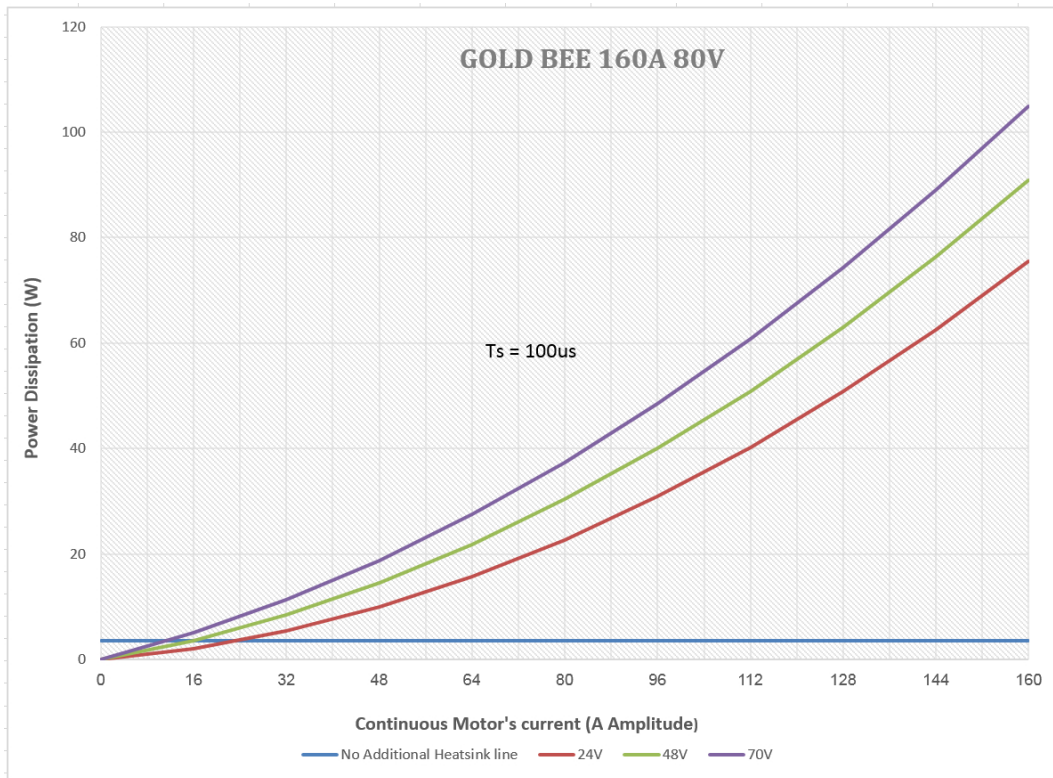

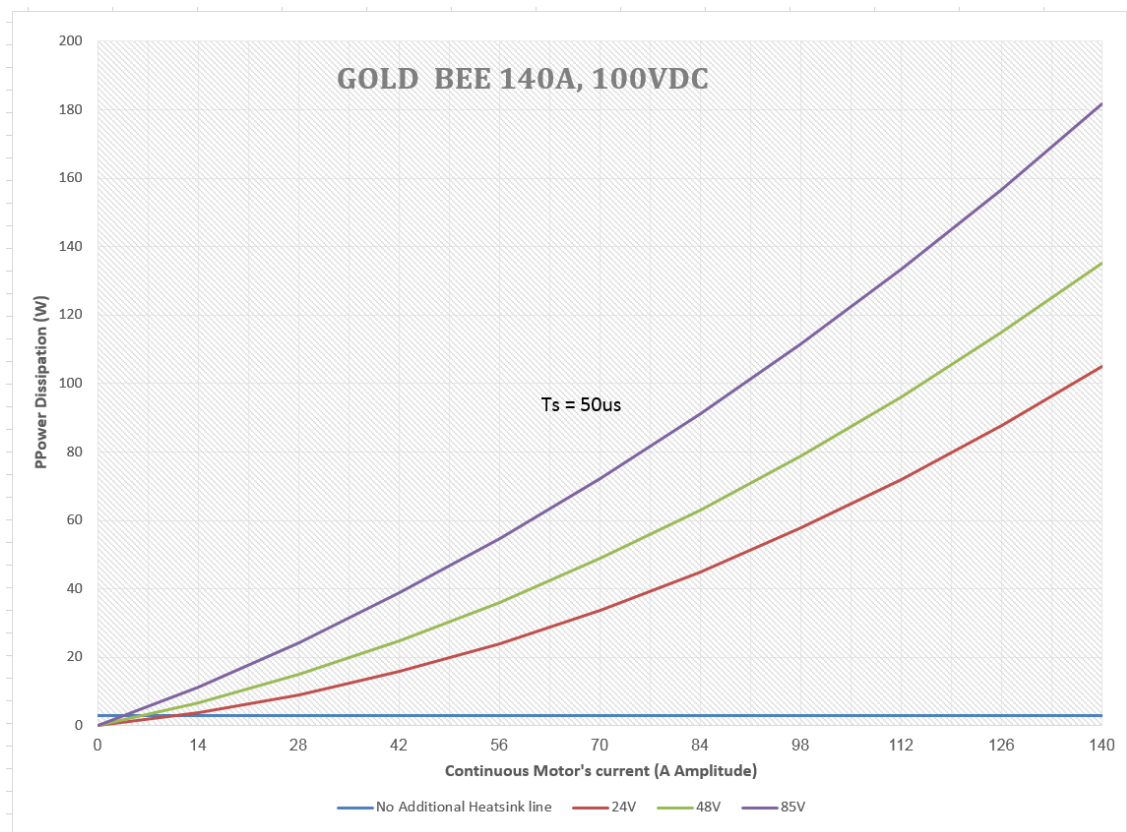
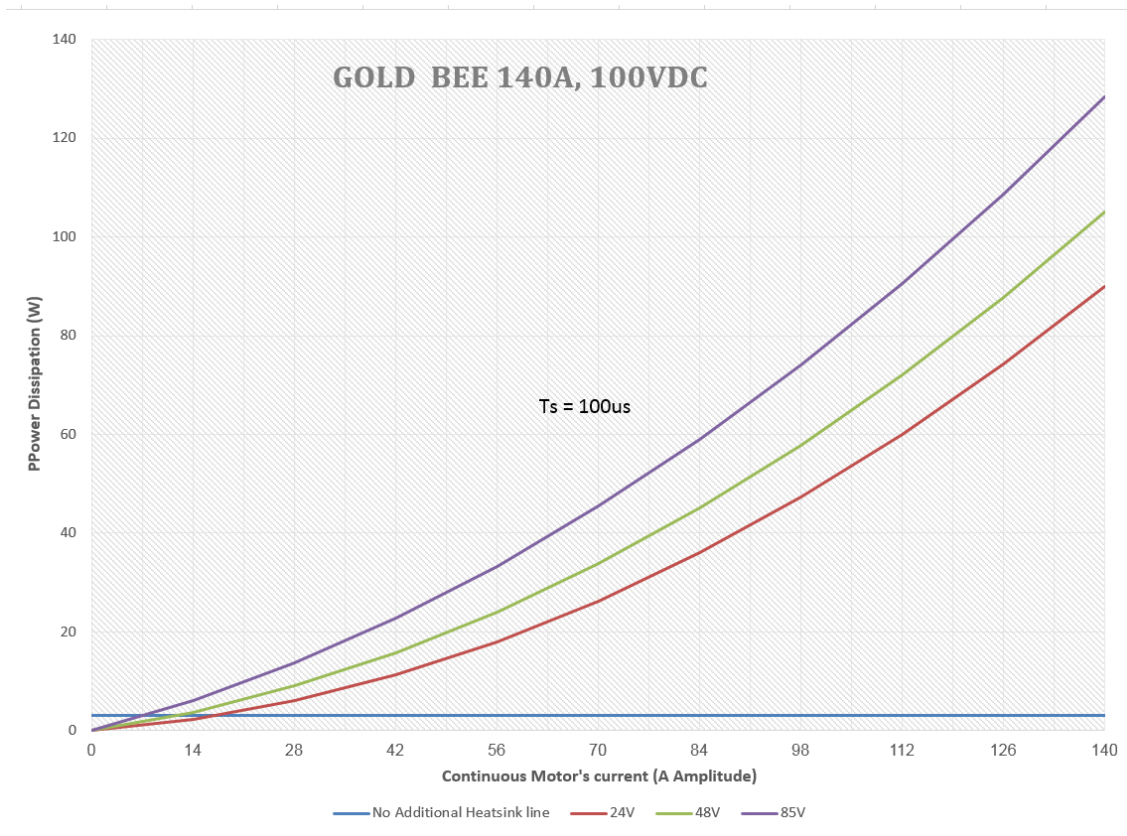

9.2.2. How to Use the Chart

The charts above are based upon the theoretical worst-case scenario. The actual test results display a 20% -30% lower power dissipation.

The above charts indicate the net power conversion losses and exclude the control losses.



To determine if your application heat dissipation requires a heat sink:

1. Determine the power dissipation according to the "continuous current" and the DC bus voltage curve.
If the DC bus is not one of the three curves above, estimate the dissipation by interpolation. The estimation error is not critical.
2. The chart is calculated for continuous current operation, if the actual operation is pulsed current, add 25% to 30% to the power dissipation of the average (RMS) current.
3. When the Heat-Sink temperature reaches $\approx 85^\circ\text{C}$, the Gold Bee will shut down. Design the system for continuous operation so that the maximum Heat Sink temperature should be no higher than between 80°C to 82°C .
4. If the average heat dissipation capability of the Heat-sink is less than $\approx 3\text{W}$ to 4W (Average operating power of 300W to 500W there will be no requirement for an additional external heat sink.
5. If the average Heat dissipation is higher than 3W then an additional heat dissipation means is required, usually by connecting to an external heat-sink.
6. When an external Heat-Sink is required, calculate the thermal resistance of the heat sink according to:

$$\theta_{\text{C/W}} = \frac{80^\circ\text{C} - T_{\text{Ambient}}}{\text{Heat Dissipation}}$$



Chapter 10: Dimensions

This chapter provides detailed technical dimensions regarding the Gold Bee.

10.1. Gold Bee CAN Version

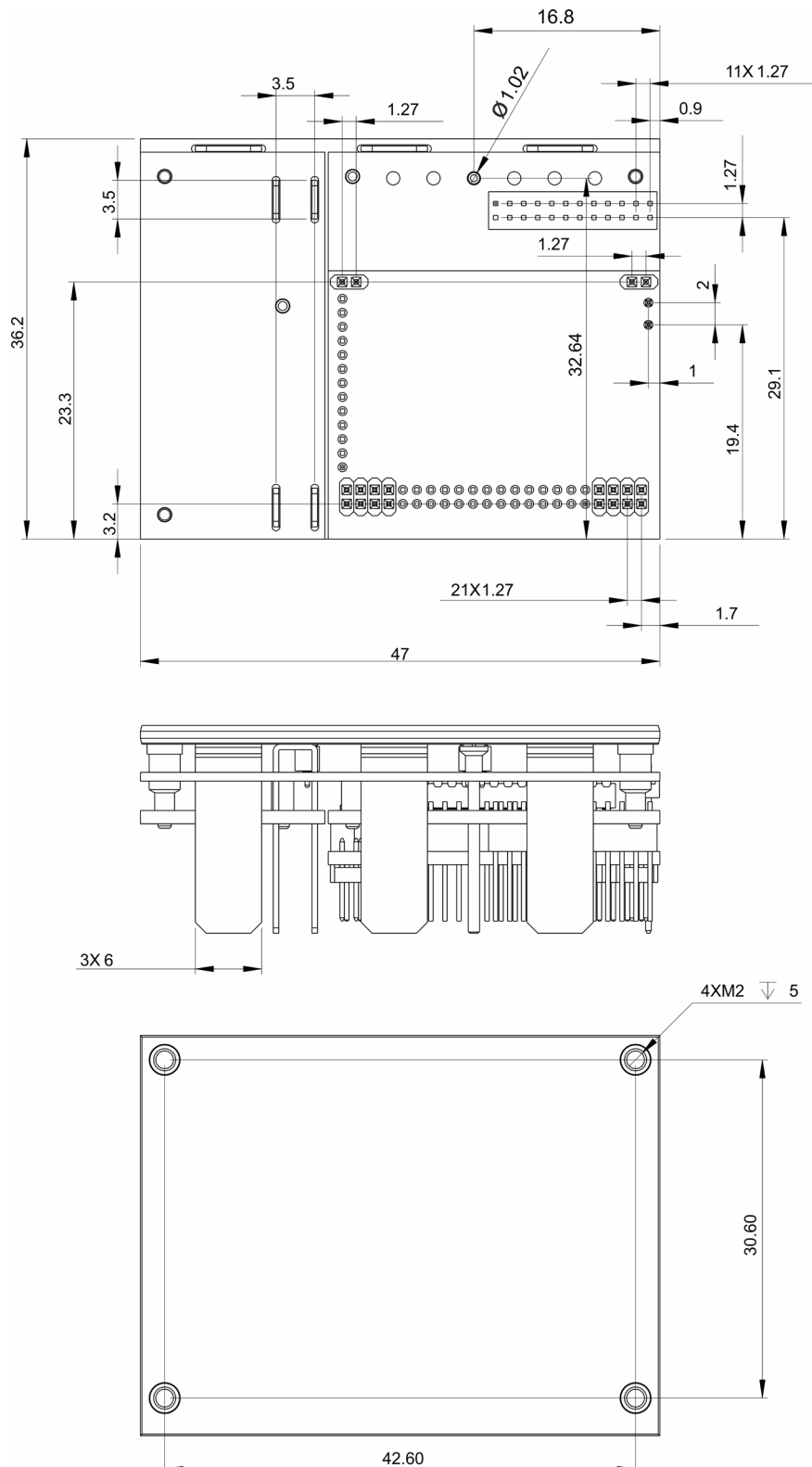

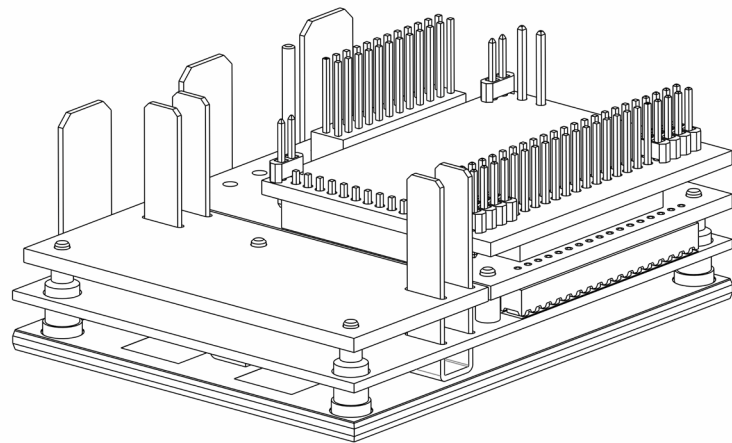
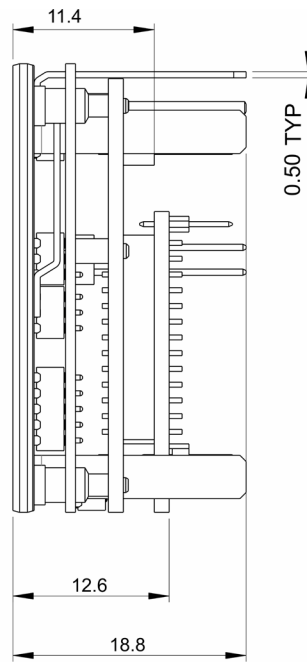

G-TWI_ADV-001A

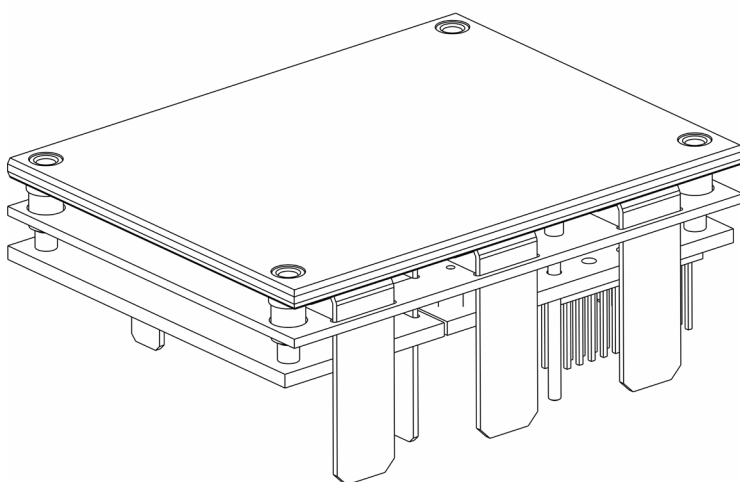
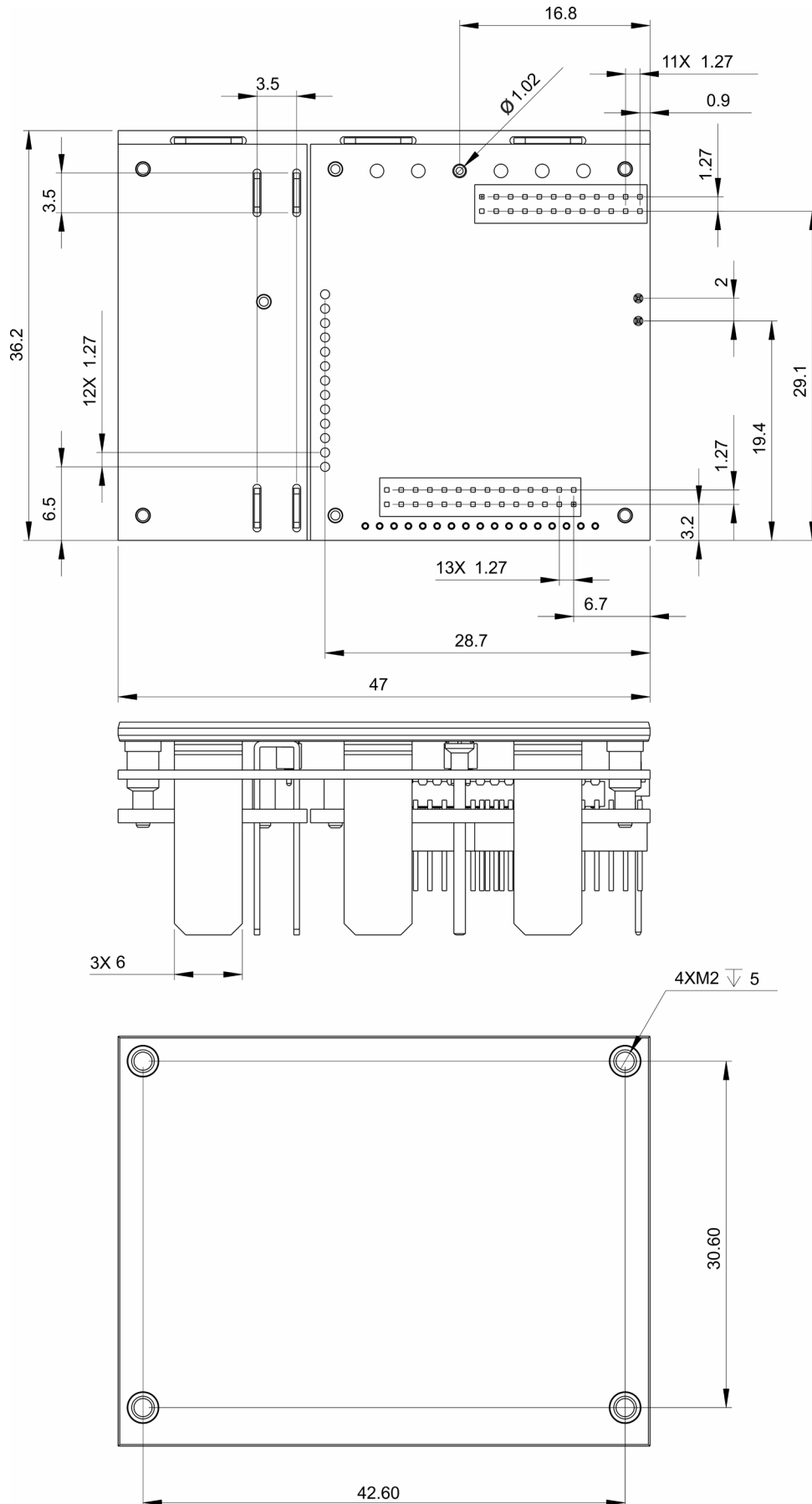
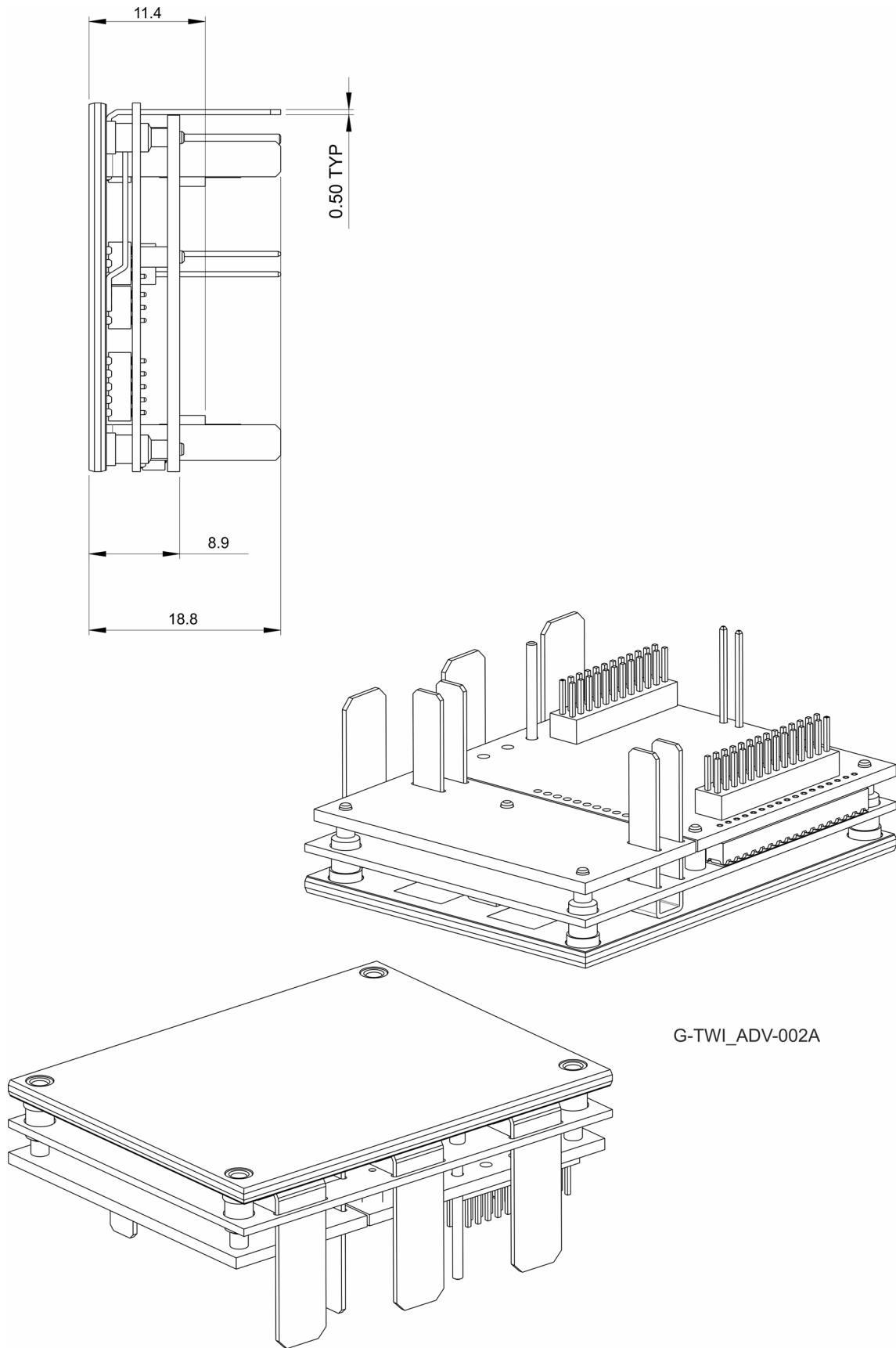

Figure 31: Gold Bee CAN Version



10.2. Gold Bee EtherCAT Version





G-TWI_ADV-002A

Figure 32: Gold Bee EtherCAT version

Inspiring Motion

Since 1988

For a list of Elmo's branches, and your local area office, refer to the Elmo site www.elmomc.com

