

# Terminology and Definition

## 1. Rated Torque

This indicates the permissible continuous load when the input rotational speed is 2000 r/min.

## 2. Permissible Peak Torque for Start/Stop

Load torque is larger than the steady torque which applied to reducer by the load inertia moment for start and stop. Values from the ratings show the acceptable value at peak torque .

## 3. Permissible maximum momentary torque

Unexpected impact torque may be applied from the exterior except regular-load torque and load torque for emergency stop.

The maximum value of the impact torque must not exceed the maximum momentary torque, if not , it can damage the reducer.

## 4. Ratcheting Torque

When excess impact torque is applied during operation, the engagement of the teeth between the circular spline and the flexspline may be put momentarily out of alignment instead of damaging the flexspline. This phenomenon is called“ratcheting, and the torque is called“ratcheting torque”(see values on the corresponding page of each series).Operating the drive without fixing ratcheting will cause earlier teeth abrasion and shorter life of the wave generator bearing due to the effect of the grinding powder generated by ratcheting.

Please pay attention for below two points:

- ① When ratcheting is occur, the teeth may not be engaged correctly (out of alignment ) , Operating without fix it will cause vibration and damage the flexspline.
- ② Once ratcheting is occur, the tips of the teeth are worn and the torque value generated by ratcheting will be lowered.

## 5. Buckling Torque

When excess torque is applied to the flexspline(output) with the wave generator fixed,the flexspline causes elastic deformation, buckles on the body before long and will be destroyed.The torque at the time is called buckling torque.

### Starting Torque(N·cm)

Model	14			17			20				25				32				40			
Reduction Ratio	50	80	100	50	80	100	50	80	100	120	50	80	100	120	50	80	100	120	50	80	100	120
HMCG-I	3.6	2.6	2.3	5.6	3.6	3.2	7.3	4.5	4.1	3.6	13	8.5	7.6	6.9	29	18	17	14	51	32	29	26
HMCG-II HMHG-II/III	4.5	3.1	2.8	6.7	4.4	3.7	8.6	5.4	4.7	4.2	17	10	8.8	8	34	21	20	17	61	39	34	31
HMHG-I	8.8	7.5	6.9	27	25	24	36	33	32	31	56	50	49	48	85	74	72	68	136	117	112	110
HMHG-IV	5.7	4.4	3.7	9.7	7.2	6.5	14	11	9.9	9.3	22	15	14	13	41	29	27	24	72	52	47	44
HMHG-V	7.9	6.4	6	11.9	9.4	8.6	16	12.7	12	11.4	30.2	23.3	21.8	21	61.2	46.8	45.6	42	-	-	-	-

Model	14			17			20				25				32			
Reduction Ratio	50	80	100	50	80	100	50	80	100	120	50	80	100	120	50	80	100	120
HMCD	4.4	3.5	2.8	6.7	4.5	3.8	8.9	5.5	5.1	-	16	10	9.1	-	32	20	20	-
HMHD	6.2	5.2	4.8	10	9	9	13	12	11	-	20	18	17	-	30	28	25	-

## Performance Parameter

### HMCG、HMHG Series

Model	Reduction Ratio	Rated torque at input 2000r/min	Permissible peak torque at start / stop	Permissible max. value of ave. load torque	Instantaneous permissible max. torque	Permissible max. input rotational speed	Permissible ave. input rotational speed	Backlash (arc sec)	Transmission accuracy (arc sec)
		Nm	Nm	Nm	Nm	r/min	r/min	≤	≤
14	50	7	23	9	46	8000	3500	20	90
	80	10	30	14	51			20	90
	100	10	36	14	70			10	90
17	50	21	44	34	91	7000	3500	20	90
	80	29	56	35	113			20	90
	100	31	70	51	143			10	90
	120	31	70	51	112			10	90
20	50	33	73	44	127	6000	3500	20	60
	80	44	96	61	165			20	60
	100	52	107	64	191			10	60
	120	52	113	64	191			10	60
	160	52	120	64	191			10	60
25	50	51	127	72	242	5500	3500	20	60
	80	82	178	113	332			20	60
	100	87	204	140	369			10	60
	120	87	217	140	395			10	60
	160	87	229	140	408			10	60
32	50	99	281	140	497	4500	3500	20	60
	80	153	395	217	738			10	60
	100	178	433	281	841			10	60
	120	178	459	281	892			10	60
	160	178	484	281	892			10	60
40	50	178	523	255	892	4000	3000	10	60
	80	268	675	369	1270			10	60
	100	345	738	484	1400			10	60
	120	382	802	586	1530			10	60
	160	382	841	586	1530			10	60

### HMCG Series Ratcheting Torque(Nm)

Reduction Ratio \ Model	14	17	20	25	32	40
50	110	190	280	580	1200	2300
80	140	260	450	880	1800	3600
100	100	200	330	650	1300	2700
120	-	150	310	610	1200	2400
160	-	-	280	580	1200	2300

### HMCG Series Buckling Torque (Nm)

Model	14	17	20	25	32	40
All Ratios	260	500	800	1700	3500	6700

### HMHG Series Ratcheting Torque(Nm)

Reduction Ratio \ Model	14	17	20	25	32	40
50	110	190	280	580	1200	2300
80	140	260	450	880	1800	3600
100	100	200	330	650	1300	2700
120	-	150	310	610	1200	2400
160	-	-	280	580	1200	2300

### HMHG Series Buckling Torque(Nm)

Model	14	17	20	25	32	40
All Ratios	210	420	700	1300	2800	5200

## HMCD、HMHD Series

Model	Reduction Ratio	Rated torque at input 2000r/min	Permissible peak torque at start / stop	Permissible max. value of ave. load torque	Instantaneous permissible max. torque	Permissible max. input rotational speed	Permissible ave. input rotational speed	Backlash (arc sec)	Transmission accuracy (arc sec)
		Nm	Nm	Nm	Nm	r/min	r/min	≤	≤
14	50	3.5	11.4	4.6	23	8000	3500	20	90
	80	5.1	15	6.2	29			20	90
	100	5.1	18	7	33			20	90
17	50	10.5	22	17	46	7000	3500	20	90
	80	14	29	21	54			20	90
	100	15	35	26	67			20	90
20	50	16	37	23	66	6000	3500	20	90
	80	23	49	28	78			10	90
	100	27	54	32	90			10	90
25	50	26	66	36	121	5500	3500	20	60
	80	42	91	62	157			10	60
	100	45	105	71	175			10	60
32	50	50	143	71	255	4500	3500	20	60
	80	79	202	126	350			10	60
	100	91	221	143	399			10	60

### HMCD Series Ratcheting Torque(Nm)

Reduction Ratio	Model	14	17	20	25	32
50		88	150	220	450	980
80		90	170	280	550	1050
100		84	160	260	500	1000

### HMCD Series Buckling Torque(Nm)

Model	14	17	20	25	32
All Ratios	190	330	560	1000	2200

### HMHD Series Ratcheting Torque(Nm)

Reduction Ratio	Model	14	17	20	25	32
50		88	150	220	450	980
80		90	170	280	550	1050
100		84	160	260	500	1000

### HMHD Series Buckling Torque(Nm)

Model	14	17	20	25	32
All Ratios	130	260	470	850	1800

## Performance Parameter

HMCG HMHG Series Hysteresis Loss and Rigidity									
Model	Reduction Ratio	T1	T2	Hysteresis Loss arcmin	Torsional Stiffness (10000 Nm/rad)			Torsional Quantity (arcmin)	
		Nm	Nm		K1	K2	K3	θ1	θ2
14	50	2	6.9	2	0.41	0.47	0.57	1.7	5.6
	>80			1	0.56	0.61	0.71	1.2	4.2
17	50	3.9	12	2	0.97	1.00	1.30	1.4	4.2
	>80			1	1.20	1.40	1.60	1.1	3.3
20	50	7	25	2	1.56	1.80	2.30	1.6	5.3
	>80			1	1.92	2.50	2.90	1.3	3.9
25	50	14	48	2	3.00	3.40	4.40	1.6	5.4
	>80			1	3.72	5.00	5.70	1.3	3.8
32	50	29	108	2	6.48	7.80	9.80	1.6	5.4
	>80			1	8.00	11.00	12.00	1.2	4.0
40	50	54	198	2	12.00	14.00	18.00	1.6	5.3
	>80			1	15.60	20.00	23.00	1.2	3.8

\*The values of Rigidity in this table are for reference, the lower-limit value is about 80% of the value listed above..

HMCD HMHDSeries Hysteresis Loss and Rigidity									
Model	Reduction Ratio	T1	T2	Hysteresis Loss arcmin	Torsional Stiffness (10000 Nm/rad)			Torsional Quantity (arcmin)	
		Nm	Nm		K1	K2	K3	θ1	θ2
14	50	2	6.9	2.5	0.29	0.37	0.47	2.4	6.4
	>80			2	0.4	0.44	0.61	1.7	5.4
17	50	3.9	12	2	0.67	0.88	1.20	2.0	4.6
	>80			1	0.84	0.94	1.30	1.6	4.3
20	50	7	25	2	1.1	1.3	2	2.2	6.6
	>80			1	1.3	1.7	2.5	1.8	5.0
25	50	14	48	2	2	2.7	3.7	2.4	6.1
	>80			1	2.7	3.7	4.7	1.8	4.5
32	50	29	108	2	4.7	6.1	8.4	2.1	6.1
	>80			1	6.1	7.8	11	1.7	4.8

\*The values of Rigidity in this table are for reference, the lower-limit value is about 80% of the value listed above..

### Rigidity

Fixing the input side (wave generator), the torsional angle and torsional stiffness when applying torque to the output side (flexspline) generates torsion almost proportional to the torque on the output side.

Torsional Stiffness = Torque T / Torsional Angle θ

K1...The torsional stiffness of the torque from 0 to T1

K2...The torsional stiffness of the torque from T1 to T2

K3...The torsional stiffness of the torque from T3 to T4

### Hysteresis Loss

Fixing the input side (wave generator), after the torque is applied up to the rated torque value, the torque is brought back to zero, the torsional angle will not become absolutely zero and a small amount remains, this calls hysteresis loss.

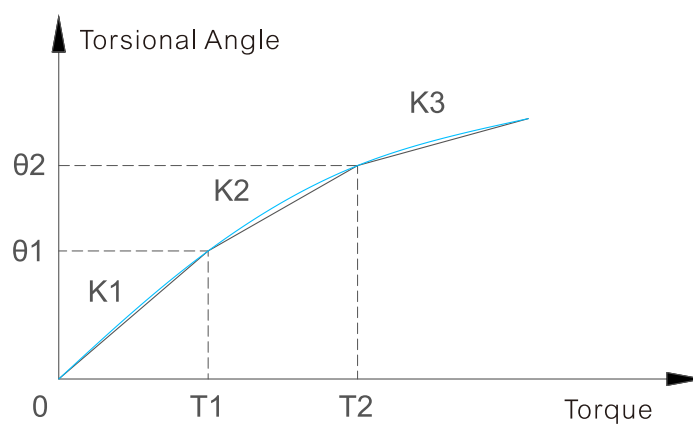

# Selection process

Please select the model according to the following flow chart. Whenever a value exceeds the rating table, reconsider a larger model or consider to reduce the load torque and other conditions.

In general, the servo system can nearly impossible operate continuously with a certain amount of load. Input speed and load torque will change, and there will be a large torque effect when starting and stopping. In addition, there will be unexpected impact torque.

### Confirmation of load torque mode

First, the mode of load torque must be mastered, please confirm the specifications shown below.

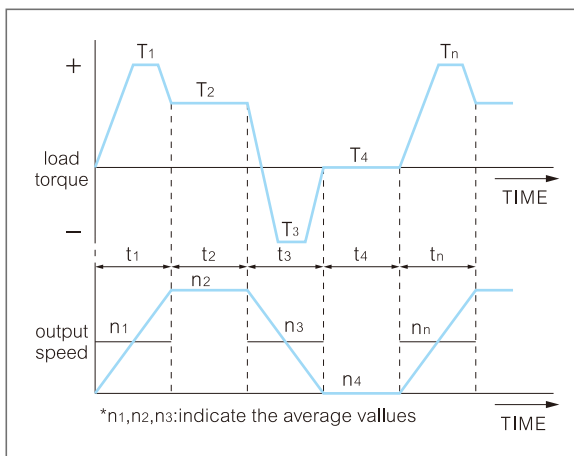

Calculate the average load torque applied to the output side of the harmonic drive according to the load torque model:  $T_{av}$  (Nm)

$$T_{av} = \sqrt[3]{\frac{n_1 \cdot t_1 \cdot |T_1|^3 + n_2 \cdot t_2 \cdot |T_2|^3 + \dots + n_n \cdot t_n \cdot |T_n|^3}{n_1 \cdot t_1 + n_2 \cdot t_2 + \dots + n_n \cdot t_n}}$$

Select the model temporarily according to the following conditions  $T_{av} \leq$  Maximum permissible value of average load torque (refer to the rated tables of each series)

- Calculate the average output speed:  $no_{av}$  (r/min)

$$no_{av} = \frac{n_1 \cdot t_1 + n_2 \cdot t_2 + \dots + n_n \cdot t_n}{t_1 + t_2 + \dots + t_n}$$

- Confirm the reduction ratio (R)  $ni_{max}$  Will be restricted according to the motor  $\frac{ni_{max}}{no_{max}} \geq R$

- Calculate the average input speed ( $ni_{av}$  (r/min)) according to the average output speed ( $no_{av}$ ) and reduction ratio (R)

$$ni_{av} = no_{av} \cdot R$$

- Calculate the maximum input speed ( $ni_{max}$  (r/min)) according to the maximum output speed ( $no_{max}$ ) and reduction ratio (R)

$$ni_{max} = no_{max} \cdot R$$

Calculate the values of each load torque mode

Load Torque	$T_n$ (Nm)
Time	$t_n$ (sec)
The output speed	$n_n$ (r/min)

### Normal mode of operation

Starting Time	$T_1, t_1, n_1$
Steady operation time	$T_2, t_2, n_2$
Stopping time (slowing)	$T_3, t_3, n_3$
Break Time	$T_4, t_4, n_4$

### Maximum rotational speed

Maximum output speed	$no_{max}$
Maximum input speed	$ni_{max}$

(restricted by motor)

### Impact torque

When impact torques applied	$T_s, t_s, n_s$
-----------------------------	-----------------

Study working condition or model again

NO Verify that the temporarily selected model is within value of the rated table.  
 $ni_{av} \leq$  Permissible average input rotational speed (r/min)  
 $ni_{max} \leq$  Permissible maximum input rotational speed (r/min)

NO Confirm whether  $T_1, T_3$  is within the allowable peak torque value of the rated table (Nm) when start or stop.

NO Confirm whether  $T_3$  is within the permissible maximum momentary torque value (Nm) of the rated table.

NO According to the output speed ( $n_s$ ) and time ( $t_s$ ) when impact torque is applied, calculate the allowable number and confirmed whether it is in accordance with the operating conditions.  

$$N_s = \frac{10^4}{2 \cdot \frac{n_s \cdot R}{60} \cdot t} \quad (r) \quad \dots \quad N_s \leq 1.0 \times 10^4 \quad (r)$$

Model is selected

## Main roller bearings Specification

Crossed roller bearing is used in the unit type to directly support the external load.

Crossed Roller Bearing Specification					
Series	Model	Rigidity	Permissible Static Torque	Rated Dynamic load	Rated Static Load
		$10^4 \text{ Nm/rad}$	Nm	$\times 10^2 \text{ N}$	$\times 10^2 \text{ N}$
HMCG-II HMCG-II-E	14	4.38	41	47	60.7
	17	7.75	64	52.9	75.5
	20	12.8	91	57.8	90
	25	24.2	156	96	151
	32	53.9	313	150	250
	40	91	450	213	365
HMHG-I HMHG-IV HMHG-II HMHG-II-E HMHG-III	14	8.5	74	58	86
	17	15.4	124	104	163
	20	25.2	187	146	220
	25	39.2	258	218	358
	32	100	580	382	654
	40	179	849	433	816
HMCD-II	14	4.38	41	47	60.7
	17	7.75	64	52.9	75.5
	20	12.8	91	57.8	90
	25	24.2	156	96	151
	32	53.9	313	150	250
HMHD-III	14	7.08	37	29	43
	17	12.7	62	52	81
	20	21	93	73	110
	25	21	129	109	179
	32	82.1	290	191	327

\*The values of Rigidity in this table are for reference, the lower-limit value is about 80% of the value listed above..

# HMHG-V series Harmonic gearbox

## HMHG-V series product details



### Unit type (Hollow & Long Shaft )

The flexspline of HMHG-V is hollow flanging standard type , the input shaft can connect to motor directly, the cable can go through the low speed hollow shaft , encoder can be installed on both input and output side. Usually it's used for cobot and joint module application.

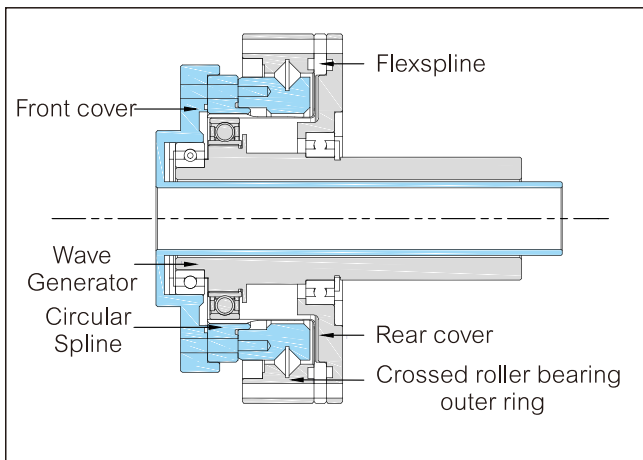

### Product features

1. Cable can go through the hollow shaft, safer and reliable
2. Doubled torque/volume ratio, as well as modular design, make it more compact with motor
3. No Backlash
4. Excellent positioning accuracy and rotation accuracy
5. Installing position of motor and encoder is small
6. Compared to HMHS series, torque capacity has been improved by 30%
7. Compared to HMHS series, life time has been improved by 43%

## HMHG-V series performance parameter

Model	Reduction ratio	Rated torque at input 2000r/min	Permissible peak torque at start / stop	Permissible max. value of ave. load torque	Instantaneous permissible max. torque	Permissible max. input rotational speed	Permissible ave. input rotational speed	Backlash (arc sec)	Transmission accuracy (arc sec)
		Nm	Nm	Nm	Nm	r/min	r/min		
14	50	7	23	9	46	8000	3500	≤ 20	≤ 90
	80	10	30	14	51			≤ 20	≤ 90
	100	10	36	14	70			≤ 10	≤ 90
17	50	21	44	34	91	7000	3500	≤ 20	≤ 90
	80	29	56	35	113			≤ 20	≤ 90
	100	31	70	51	143			≤ 10	≤ 90
20	50	33	73	44	127	6000	3500	≤ 20	≤ 60
	80	44	96	61	165			≤ 20	≤ 60
	100	52	107	64	191			≤ 10	≤ 60
	120	52	113	64	191			≤ 10	≤ 60
25	50	51	127	72	242	5500	3500	≤ 20	≤ 60
	80	82	178	113	332			≤ 20	≤ 60
	100	87	204	140	369			≤ 10	≤ 60
	120	87	217	140	395			≤ 10	≤ 60
32	50	99	281	140	497	4500	3500	≤ 20	≤ 60
	80	153	395	217	738			≤ 10	≤ 60
	100	178	433	281	841			≤ 10	≤ 60
	120	178	459	281	892			≤ 10	≤ 60
40	50	178	523	255	892	4000	3000	≤ 10	≤ 60
	80	268	675	369	1270			≤ 10	≤ 60
	100	345	738	484	1400			≤ 10	≤ 60
	120	382	802	586	1530			≤ 10	≤ 60

# HMHG-V series Harmonic gearbox

HMHG-14-XX-V

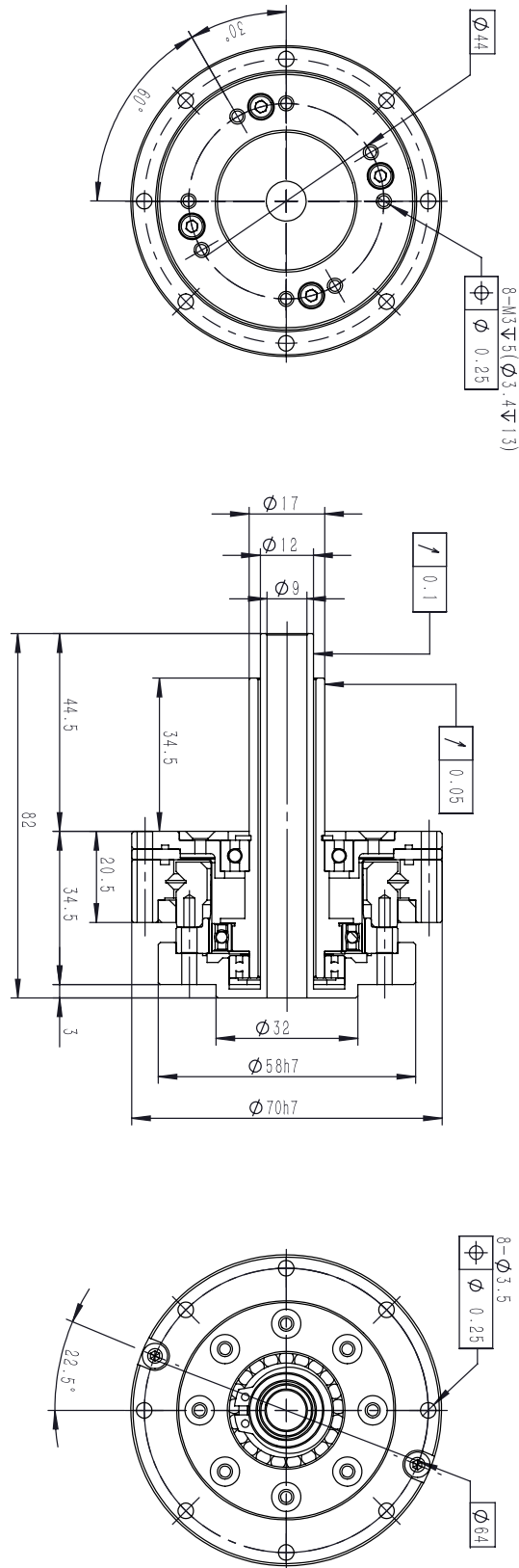



# HMHG-V series Harmonic gearbox

HMHG-17-XX-V

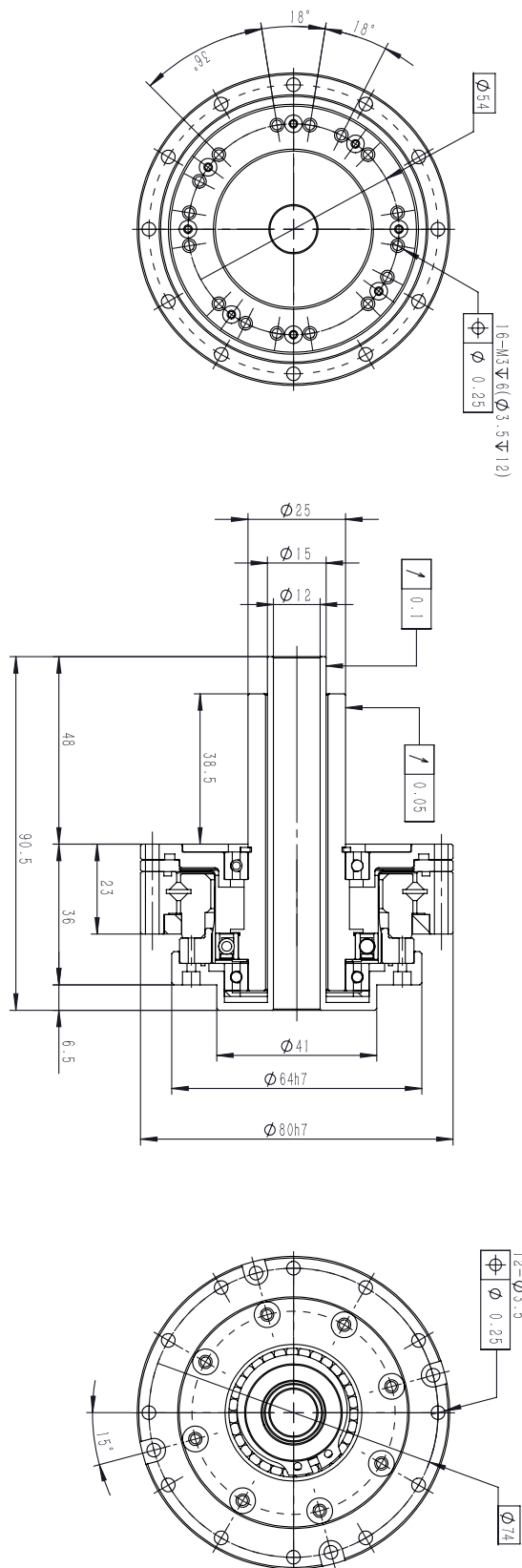

# HMHG-V series Harmonic gearbox

HMHG-20-XX-V

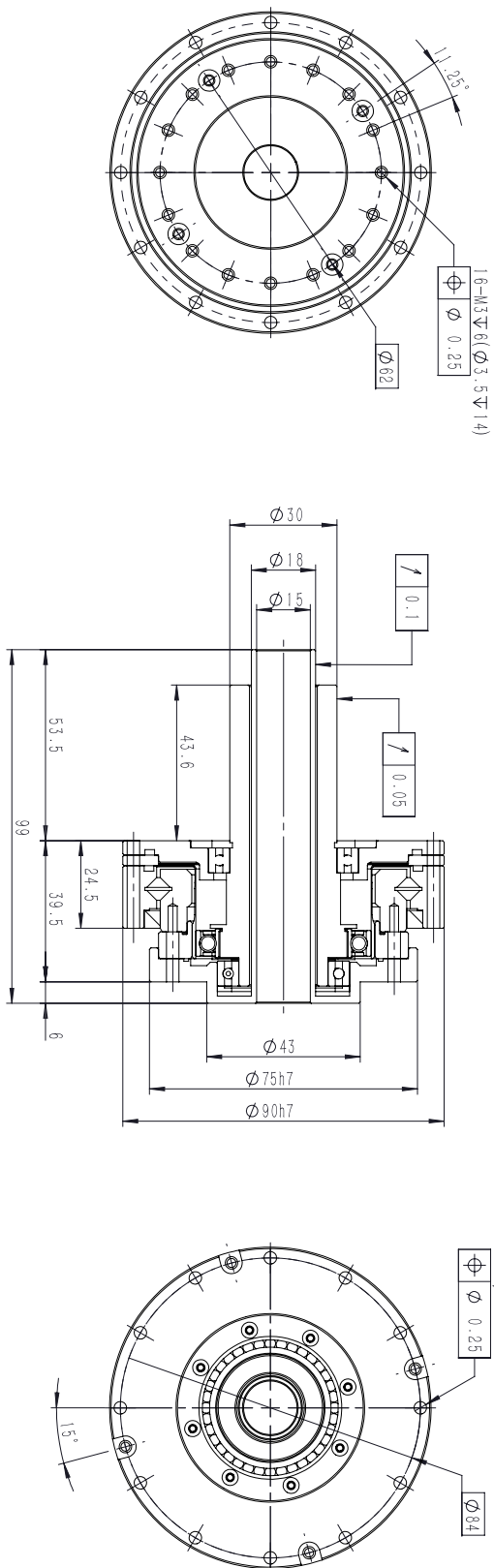

# HMHG-V series Harmonic gearbox

HMHG-25-XX-V

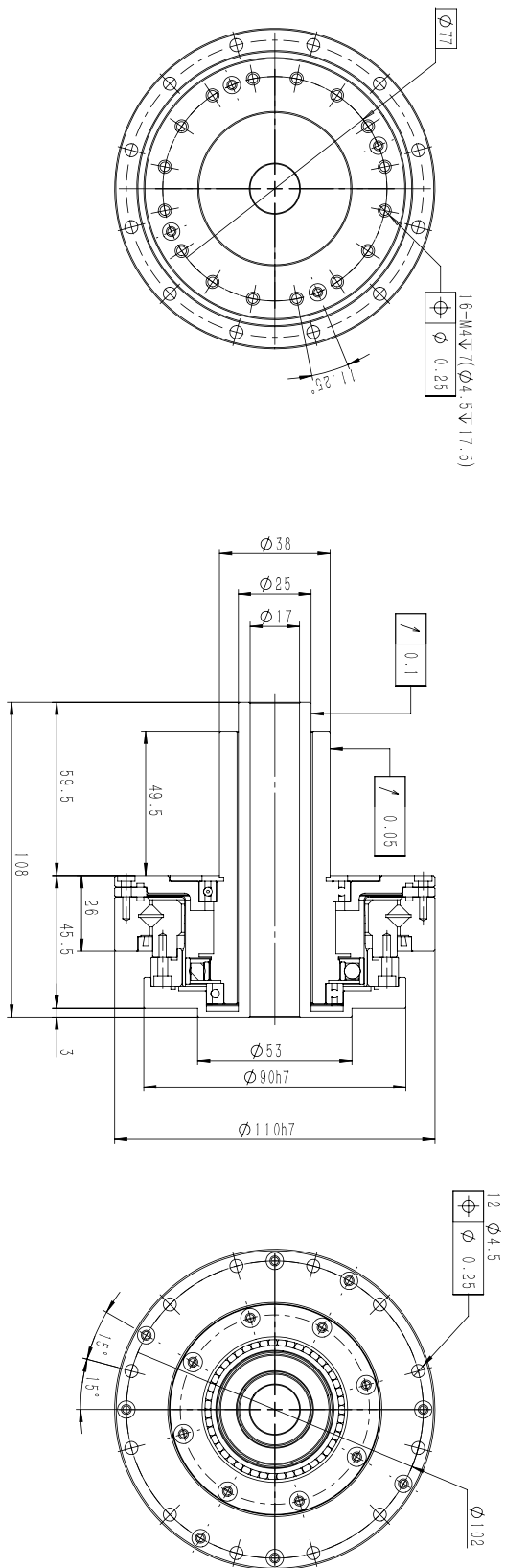

# HMHG-V series Harmonic gearbox

HMHG-32-XX-V

