





MEMS Inertial Measurement Unit V 1.00

BS-IC208-M-D6EC



### Product characteristics

---

-  Gyroscope measuring range: 500 °/s optional
-  0.3 °/H gyroscope bias stability (Allan variance)
-  Acceleration range: 16g
-  0.02 mg acceleration bias stability (Allan variance)

### Field of application

---

UAV Navigation



Vehicle & Robot Navigation



AUV & ROV



## 1. Product overview

---

The BS-IC208-M-D6EC is an inertial measurement unit (IMU) based on micromachining technology (MEMS) with built-in high-performance MEMS gyroscope and MEMS accelerometer, which outputs 3 angular velocities and 3 accelerations. The utility model has the advantages of high reliability and strong environmental adaptability. By matching different software, the product can be widely used in tactical and industrial UAV, smart ammunition, seeker and other fields.

## 2. Product features

---

### 1) Three-axis digital gyroscope:

A)  $\pm 500^\circ/\text{s}$  dynamic measuring range;

B) Zero bias stability:  $10^\circ/\text{H}$  (GJB, 10s),  $2.0^\circ/\text{H}$  (ALLAN);

### 2) Triaxial digital accelerometer:

A)  $\pm 16\text{ G}$  dynamic measuring range;

B) Zero-bias stability:  $0.5\text{ mg}$  (GJB, 10s),  $0.1\text{ mg}$  (ALLAN);

3) High reliability: MTBF > 20000h;

4) Guaranteed accuracy within the full temperature range ( $-40^\circ\text{C} \sim 80^\circ\text{C}$ ): built-in high-performance temperature calibration and compensation algorithm;

5) Suitable for working under strong vibration conditions

6) Interface 1-way RS422

7) Compatible with STIM300

## 3. Product indicators

Parameter		Test conditions	Design accuracy	Unit
Peg-top	Dynamic measuring range	-	$\pm 500$	$^\circ/\text{s}$
	Zero bias stability	Allan variance (500 $^\circ/\text{s}$ range, normal temperature)	0.3	$^\circ/\text{h}$
		10 s average ( $-40^\circ\text{C} \sim +80^\circ\text{C}$ , constant temperature),	3.0	$^\circ/\text{h}$
	Zero bias	Zero bias range	0.1	$^\circ/\text{s}$
		Zero-bias variation over full temperature range	0.01	$^\circ/\text{s}$
		Start repeatability	0.005	$^\circ/\text{s}$
		Effect of linear acceleration on bias	0.002	$^\circ/\text{s/g}$
		Influence of vibration on zero bias, change before and after vibration	0.002	$^\circ/\text{s/g}$

Parameter		Test conditions	Design accuracy	Unit
		Influence of vibration on zero bias, change before and during vibration	0.001	°/s/g
	Scale factor	Scale factor accuracy	0.1	%
		Scale factor nonlinearity	0.01	%FS
	Angular random walk	-	0.06	°/√hr
Bandwidth	-	200	Hz	
Accelerometer	Dynamic measuring range	-	16	g
	Zero bias stability	Allan variance (16g range, normal temperature)	0.02	mg
		10 s average (-40 °C ~ + 80 °C, constant temperature)	0.03	mg
	Zero bias	Zero bias range	1	mg
		Zero-bias variation over full temperature range	1	mg
		Start repeatability	0.2	mg
	Scale factor	Scale factor accuracy	0.3	%
		Scale factor nonlinearity	0.02	%FS
Speed random walk	-	0.08	m/s/√hr	
Bandwidth	-	200	Hz	
Communication interface	1-way SR422	Baud rate	460.8	MHz
	Sampling frequency	UART	1000	Hz
Electrical characteristics	Voltage	-	5	V
	Power consumption	-	1.5	W
	Ripple	P-P	150	mV
Structural characteristics	Size	-	38.6×44.6×21.5	mm
	Weight	-	65±2	g
Use environment	Operating temperature	-	-40~80	°C
	Storage	-	-45~85	°C

Parameter		Test conditions	Design accuracy	Unit
	temperature			
	Vibration	-	20~2000Hz, 6.06g	
	Impact	-	6000g, 0.5m s	
Reliability	MTBF	-	20000	h
	Continuous working time	-	120	h

#### 4. Electrical interface

The electrical connector of BS-IC208-M-D6EC product is J30J-15 TjL, and the specific contact definition and allocation are shown in the following table

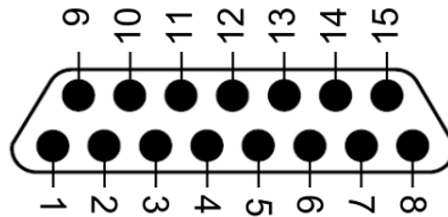

Figure 1 Connector Node Configuration

Stitch	Name	Type		Stitch	Name	Type
1	TxD-	Output	RS422	8	VCC_5V	Power source
2	RxD-	Input	RS422	9	TxD+	Output (RS422)
3	TST_1	Output		10	RxD+	Input (RS422)
4	TOV_1	Output		11	ExtTrig	Input (synchronous)
5	RST	Input		12	GND	Input
6	GND	Input		13	GND	Input
7	Spare			14	Spare	
8	VCC_5V	Power	+5v	15	GND	Power ground

Table 1 3 J0J-15 TjL Connector Contact Definition Distribution Table

## 5. Fabric interface

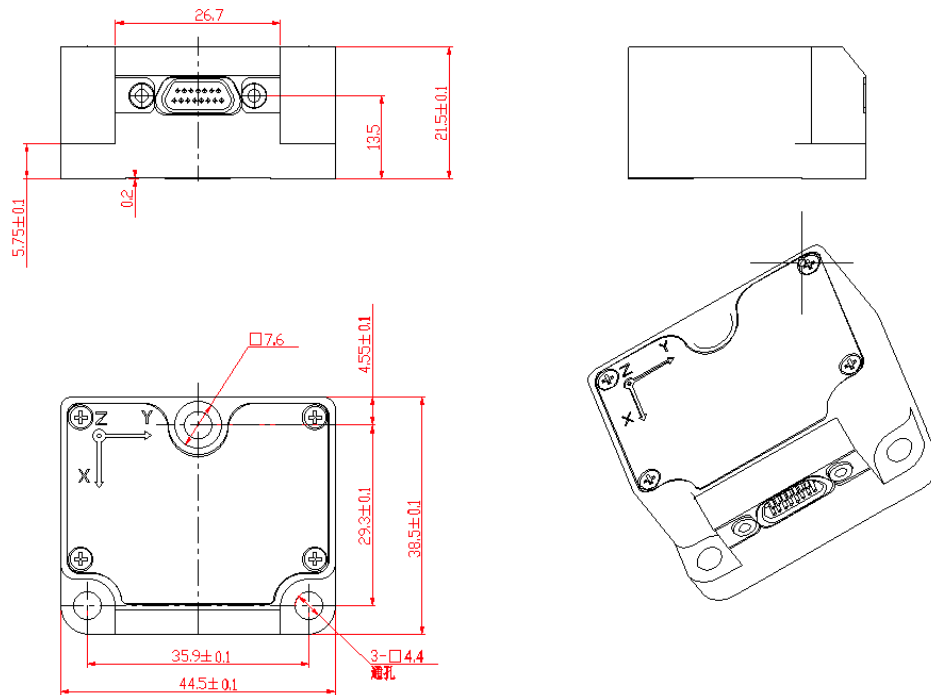

Fig. 2 Schematic Diagram of Structure Appearance

## 6. Instructions for use

### 6.1 UART read-write data

#### 6.1.1 protocol format

Agreement	Byte sequence number	Data	Unit	Data type	Remark
Protocol header	0	0x5a			
	1	0x5a			

Protocol body	2~5	X-axis gyro	°/s	float	
	6~9	Y-axis gyro	°/s	float	
	10~13	Z-axis gyro	°/s	float	
	14~17	X-axis plus table	g	float	
	18~21	Y-axis plus table	g	float	
	22~25	Z-axis plus table	g	float	
	26~29	Spare			
	30~33	Spare			
	34~37	Spare			
	38~41	Spare			
	42~45	Spare			
	46~49	Temperatur e	°C	float	
	50~53	Spare			
	54~57	Spare			
End of agreement	58	Checksum			Accumulate and sum 2 to 57 bytes, take the low byte

## 7. Update the record

Serial		Change the	Before	After the change	Reason for the	Changed
1	1.00	20230103		New preparation,	New	Zzy