

---

# **BS-FL80x-M-D6EC**

**Fiber optic inertial measurement unit**

## **Operation Instructions**



# BS-FL80x-M-D6EC

## Technical specifications of fiber optic inertial measurement units

### 1.Introduction

The fiber optic inertial measurement unit is an inertial product developed for navigation guidance, attitude measurement and control systems of small missiles and guided bombs. It consists of three solid-state fiber optic gyroscopes, three quartz accelerometer, and a data packaging board. It measures the angular velocity and linear acceleration of the carrier's motion, providing information for the carrier's attitude and navigation control. The measurement results are output through the RS422 serial port.

#### 1.1 Application scope

This manual is only applicable to BS-FL80x-M-D6EC products and includes performance indicators, technical conditions, external dimensions, and installation and use. Among them, the technical conditions include the environmental range, electrical performance, and physical characteristics of the product.

#### 1.2 Parameters

**Product name: BS-FL80x-M-D6EC, x - gyroscope parameters**

**BS-FL80H-M-D6EC**

**BS-FL80M-M-D6EC**

##### 1.2.1 Main performance indicators of fiber optic gyroscope:

Table 1 Main Performance Indicators of the Product

	Main indicator parameters	H-type	M-type
Main performance indicators of fiber optic gyroscope	Room temperature zero bias repeatability (sequential, daily) (°/h)	≤0.3	≤0.5
	Zero bias stability at constant temperature (°/h)	≤0.3	≤0.5
	Repeatability of Room Temperature Scale Factor (ppm)	≤30	≤50
	Asymmetric scaling factor at constant temperature (ppm)	≤20	≤30
	Scale factor nonlinearity at constant temperature (ppm)	≤20	≤30

	Threshold (°/h)	$\leq 0.5^\circ / h$
	Angular rate range (°/s)	-500~+500 °/s
	Bandwidth (Hz)	100
	Size (mm)	$\Phi 80*70$
	Weight (g)	780±20 (Including accelerometer)
	Working temperature (°C)	-40~+65

Quartz accelerometer parameters		
Number	Main indicator parameters	technical regulations
1	Range (g)	$\geq \pm 40$
2	Scale factor temperature coefficient (ppm/°C)	$\leq 100$
3	Scale Factor Monthly Stability (ppm)	$\leq 100$
4	Bias value (mg)	$\leq \pm 7$
5	Bias temperature coefficient ( $\mu g/^\circ C$ )	$\leq 100$
6	Partial monthly stability ( $\mu g$ )	$\leq 100$
7	Second-order nonlinear coefficient ( $\mu g/g^2$ )	$\leq 20$
8	Installation angle (")	$\leq 200$
9	appearance	No scratches, cracks, or rust
10	insulation	$\geq 20M \Omega$ ; (100V), 25 °C ± 5 °C, humidity $\leq 80\%$

## 1.2.2 Mechanical testing

### 1.2.2.1 Sinusoidal scanning vibration

The gyroscope is fixed on the vibration table through tooling in the vibration direction, and the gyroscope performs sine scanning in three directions, corresponding to the X axis, Y axis, and Z axis

directions. Vibration steps; Excitation is applied to the vibration table, and the gyroscope is powered on. After preheating for a certain time (starting time of the gyroscope), the output value of the gyroscope is tested for about 5 minutes; Perform sinusoidal vibration. Vibration conditions: 20Hz-2000Hz, scanning time 5 minutes, amplitude 4.2g. During the vibration process, record the output of the gyroscope.

Random vibration

Vibration frequency: 20Hz~2000Hz

Vibration time: 5 minutes for each axis

Vibration direction: X, Y, Z axis

Vibration spectrum diagram: see Figure 1

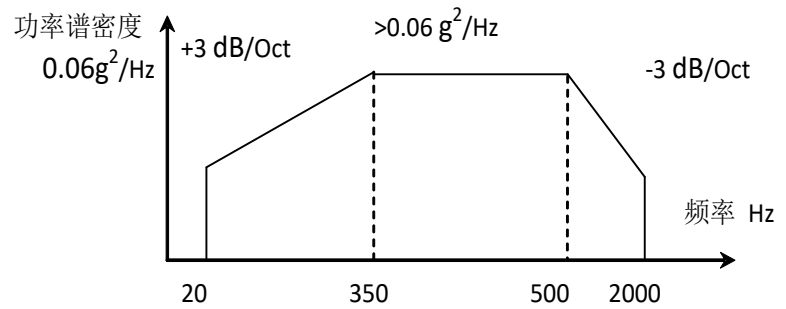

Indicator requirements:

Fiber optic gyroscope has no resonance during sine sweep frequency scanning in the range of 20Hz to 2000Hz;

Random vibration: The absolute value between the zero deviation value at the center of the vibration and the average zero deviation value before and after the vibration should be less than 1 °/h.。

### 1.2.2.2 Mechanical impact shall comply with the requirements of Table 2.

Table 2 Impact Test Conditions

Peak acceleration (g)	30
Duration (ms)	10
Number of impacts	3 times in each direction
Waveform	half sine wave
Direction	X、 Y、 Z
	Note: The interval between two impacts shall not be less than 1.5 seconds

During the impact process, the product is in an energized state, and after completing the mechanical impact, it should be able to work normally. The zero position change before and after the impact is less than 1 °/h.

---

## 2.1 IMU Data Transmission Protocol

### Attachment A:

Baud rate: 460800, no check bit, 1 stop bit

Sending frequency: 400Hz

Sending data protocol:

Byte	Name	Unit	Value	Conversion	Type
0	Frame header byte 1		0xAA		uchar
1	Frame header byte 2		0xAA		uchar
2	Data transmission count		1~200		uchar
3	Self check byte		255		uchar
4~7	X-axis gyroscope		32bit low in front, high in back		signed int32
8~11	Y-axis gyroscope		32bit low in front, high in back		signed int32
12~15	Z-axis gyroscope		32bit low in front, high in back		signed int32
16~19	X-axis accelerometer		32bit low in front, high in back		signed int32
20~23	Y-axis accelerometer		32bit low in front, high in back		signed int32
24~27	Z-axis accelerometer		32bit low in front, high in back		signed int32
28,29	X-axis gyroscope temperature		16bit low in front, high in back	1/16	signed int16
30	Checksum		4-29 Byte XOR and		uchar
31	End of Frame		0xBB		uchar

## 3、Wiring Definition

BS-FL80x-M-D6EC Output definition
-----------------------------------

J30J-15ZK	define	notes
5、13	+24V	Inertial group power supply
6、7	+24V (ground)	
1	T3+	Inertial Navigation Data Serial Port
2	T3-	
3	R3+	
4	R3-	
11	T2+	IMU Data output serial port
12	T2-	
14	T1+	Debug UART
15	T1-	
9	R1+	
10	R1-	

#### 4、Product dimensions

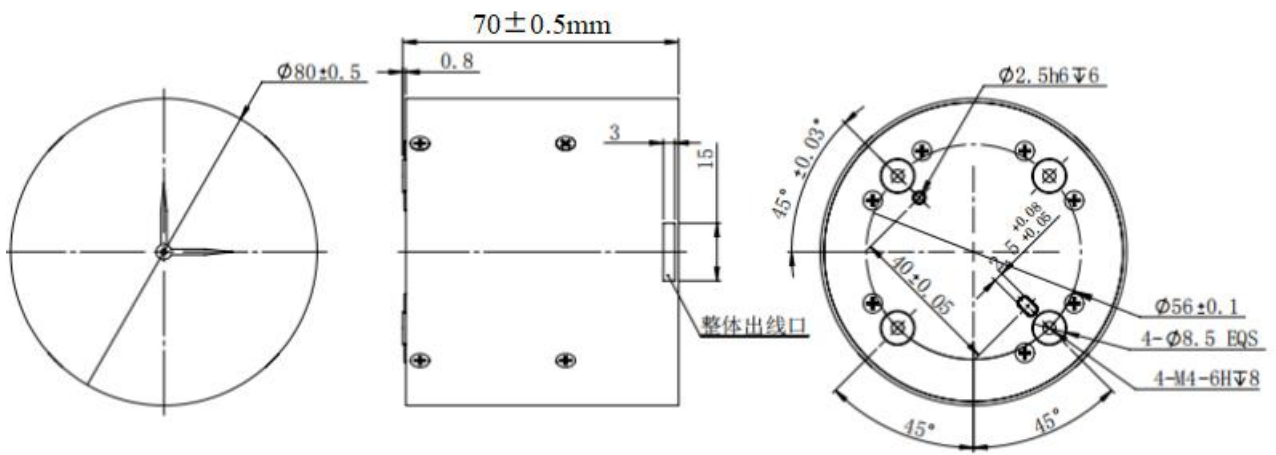

**BS-FL80x-M-D6EC Outline Dimensional Drawing**