

BS-FG91-240-A1EC Fiber Optic Gyro



1 Introduction

1.1 Product Review

BS-FG91-240-A1EC fiber gyro (hereinafter referred to as this product) is an angular rate sensor integrating light, mechanical and electrical. Based on the Sagnac effect, it integrates a variety of highly reliable micro-nano fiber devices to achieve the detection process by detecting, processing and feedback the phase difference generated by two beams of light propagating in the opposite direction. This product realizes ultra-high rotational speed measurement through the redesign of optics, structural support, and control algorithms.

This product is mainly composed of optical path components, circuit components and structural components. It has the characteristics of simple structure, no moving parts, no wear parts, impact resistance, fast start, small size, light weight and high reliability. It can be applied to the control and measurement of motion carriers.

1.2 Composition

The product is mainly composed of the following components:

- a) optical path components;
- b) Detection and control signal circuit board;
- c) Optical fiber ring skeleton, shell and other structural parts;

1.3 Size

82mm×82mm×19.5mm (not include plug) .

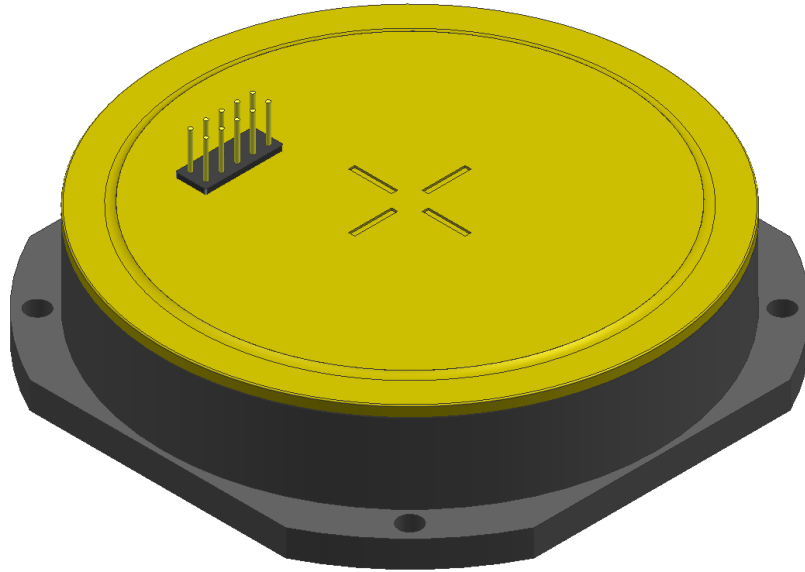

Fig 1 BS-FG91-240-A1EC

1.4 Weight

≤150g。

1.5 Working Temperature

-40℃~+70℃。

1.6 Store Temperature

-55℃~+85℃。

1.7 Random vibration

Random vibration level: 20g, frequency range: 20Hz~ 2000Hz.

1.8 Main Parameters

Table 1 Parameters

No.	Items	Value
1	Range (°/s)	±240
2	Scale factor (mV/°/s)	47±5
3	Scale factor nonlinearity (ppm)	≤1000
4	Bias stability (10s,1σ, °/h)	≤0.8
5	Bias repeatability (1σ, °/h)	≤0.8
6	3dB bandwidth (Hz)	≥1000
7	Random walk (°/√h)	≤0.02
8	Power supply (V)	5±0.25 ±12
9	Power Consumption(W)	≤1.5
10	Vibration	5g(10~2000Hz)
11	Impact (g)	≥1500
12	Acceleration (g)	≥70
13	Working life years (Computational Evaluation)	≥15
14	MTBF (Computational Evaluation)	≥100000

2 Interface

2.1 physical interface

The bottom surface of the product is the mounting surface, and the external dimensions and mounting interfaces are as follows:

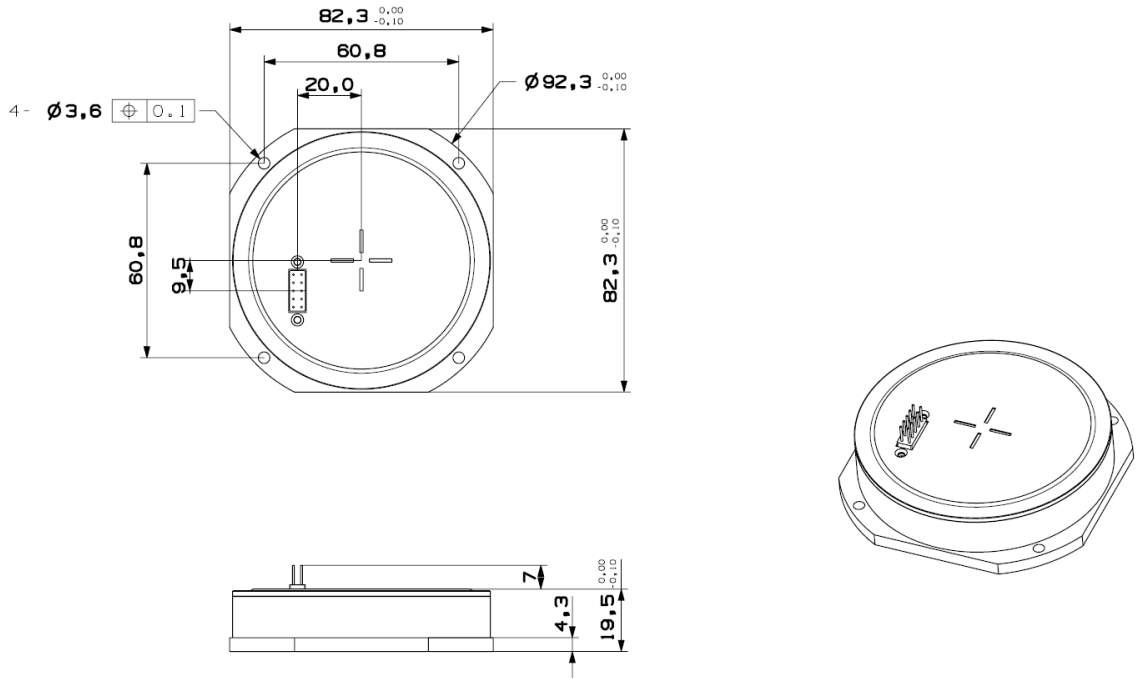

Fig 2 BS-FG91-240-A1EC dimension

2.2 Power supply requirement

The external power supply to the product is three-way, and the requirements are shown in

Table 2:

Table 2 power supply requirement

	voltage (v)
1	5 \pm 0.25
2	12 \pm 0.5
3	-12 \pm 0.5

2.3 Electrical Interface

BS-FG91-240-A1EC The micro-nano fiber gyro adopts a pitch of 2.54mm double-row pins to connect electrically with the outside.

Table 3 BS-FG91-240-A1EC Node definition

No.	Definition	Remark
1	5V	Power consumption is less than 1W

2	12V	
3	Output	Differential output with AGND
4	-12V	
5	AGND	Analog GND
6	GND	
7	空	
8	GND	Power GND
9	TS	TMP temperature sensor signal Conversion relationships $T = (TS - 750) / 10 + 25$ The unit is mV, T is the temperature in Celsius

Electrical connection as fig 3:

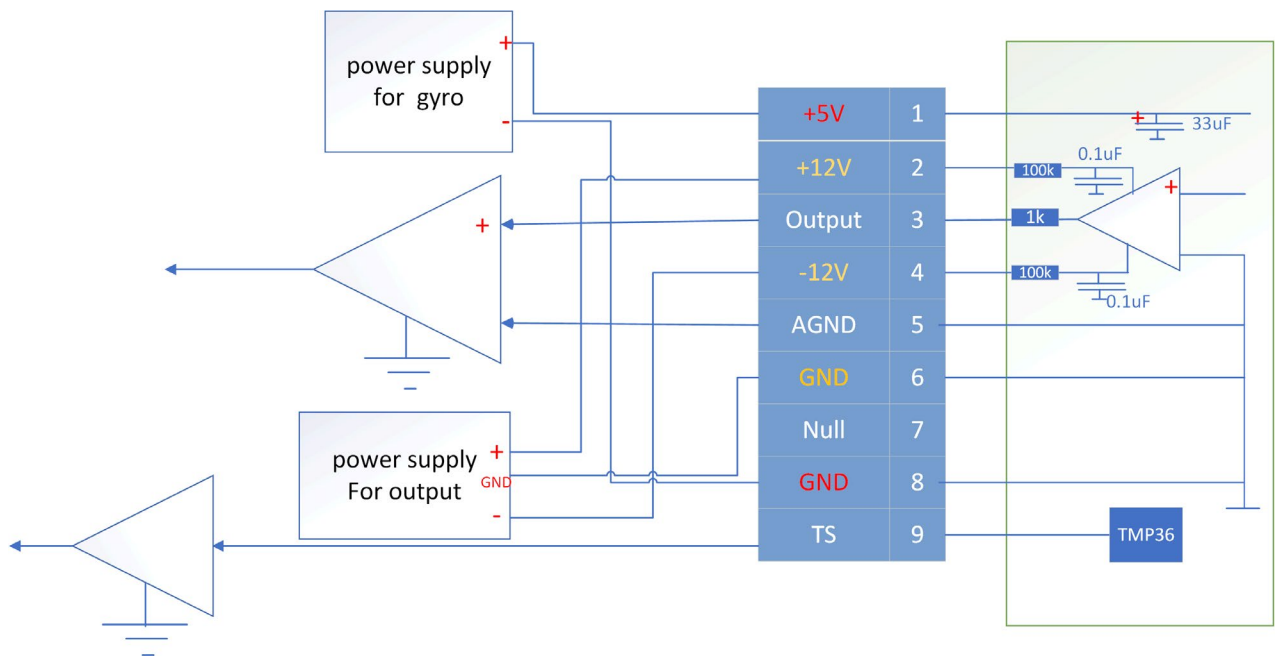

Fig 3 electrical connection