BS-FC103-350-A1EC

FOG

Product Specification



BS-FC103-350-A1EC product specification

1 Product introduction

1.1 Product Overview

BS-FC103-350-A1EC is an angular rate sensor that integrates optics, structure, and electricity. Based on the Sagnac effect, it integrates a variety of high-reliability micro-nano fiber optic devices, and feeds back the detection process by detecting the phase difference between two beams of light propagating in opposite directions.

This product is mainly composed of optical path components, circuit components, and structural components. It has the characteristics of simple structure, no moving parts, no wear parts, shock resistance, fast start-up, small size, light weight, and high reliability. It can be used for control and measurement of motion carriers.

1.2 Product Composition The product mainly consists of the following components, etc:

- a) Optical circuit assembly;
- b) detection and control signal circuit board;
- c) Fiber ring skeleton, housing and other structural components.

1.3 Dimensions

63 mm×63 mm×22 mm (Connector not included)

Figure 1 BS-FC103-350-A1EC

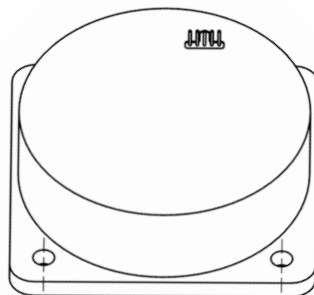

1.4 Weight

≤80 g.

1.5 Operating Temperature

-40°C~+70°C.

1.6 Endurance Temperature

-55°C~+85°C.

1.7 Random Vibration

20g, 20Hz~ 2000Hz.

1.8 Specifications

Table 1 Specifications

No.	Content	Parameters
1	Input range (°/s)	±350
2	Scale factor (mV/°/s)	6.2±10%
3	Scale factor RMS (ppm)	≤200
4	Scale factor OTR (ppm/°C)	300±50
5	Bias stability (10s, 1σ, °/h)	≤0.8
6	Bias Repeatability (1σ, °/h)	≤0.8
7	3dB Bandwidth (Hz)	≥2000
8	Angular random walk (°/√h)	≤0.02
9	Output noise PSD (mV/√Hz)	≤2
10	Bias offset (mV)	≤0.1
11	Bias OTR (mV/°C)	≤±1
12	Start-up (s)	≤ 0.03
13	Power supply (V)	5±0.25
14	Dissipation (W)	≤0.5
15	shocks (g)	≥1500
16	Acceleration (g)	≥70
17	Life (years)	≥15

18	MTBF	≥100000
----	------	---------

2 Interface

2.1 Mount Interface

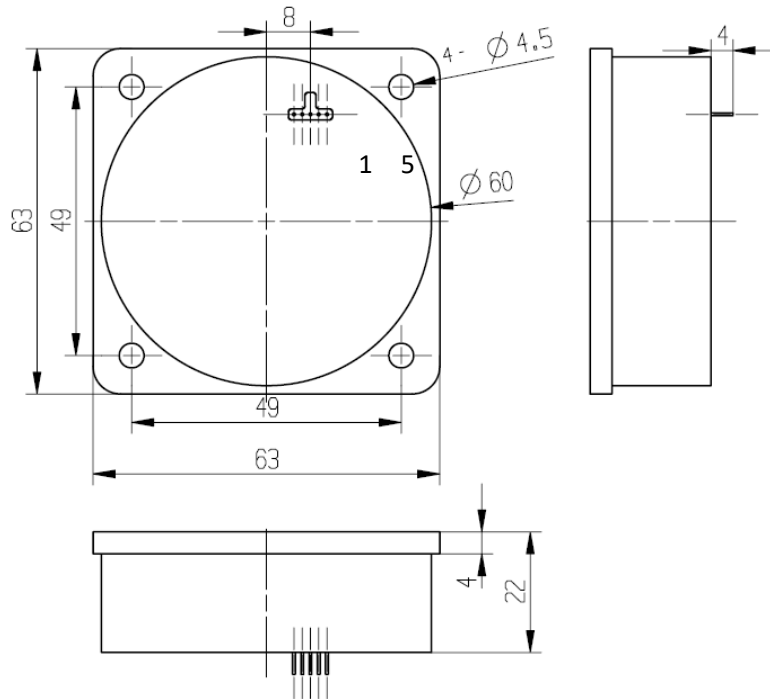

Figure 2 Mount interface of BS-FC103-350-A1EC

2.3 Electric Interface

BS-FC103-350-A1EC uses a single row of pins with a pitch of 2.54 mm for electrical connection to the outside.

Table 3 BS-FC103-350-A1EC Pin Assignment

No.	Definition	Remark
1	TS	$V(TS) = 0.5 + t^{\circ}C/100$
2	5V	
3	Output-	
4	Output+	
5	GND	