

AM-40XB(CSF-11) Series

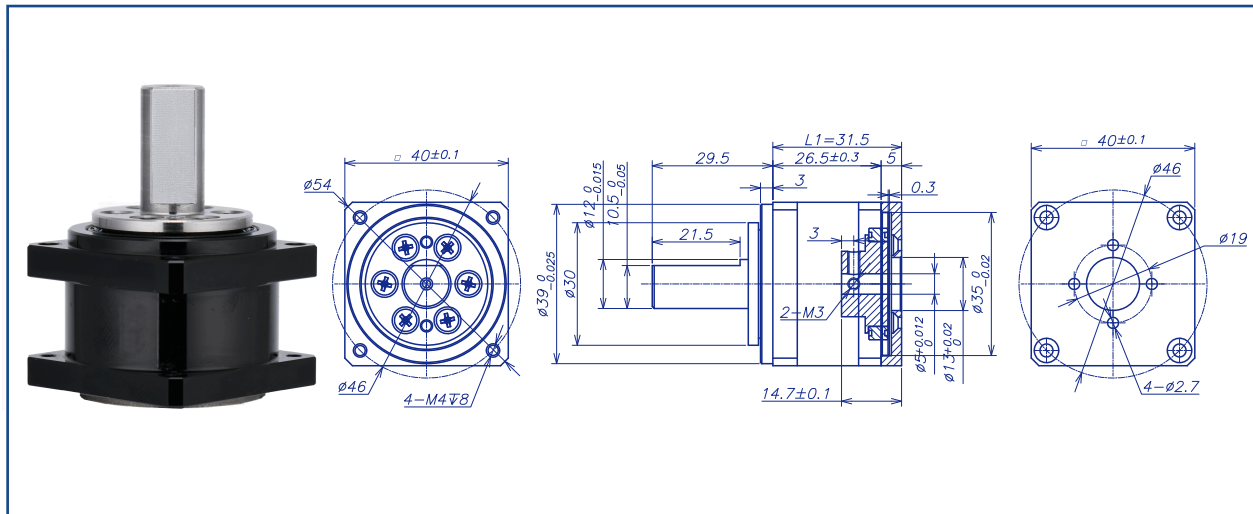

PARAMETER

Reduction ratio	30	50	80	100
Nominal torque at input speed 2000r/min(N.m)	2.1	3.5	4.5	5
Peak torque at start-stop(N.m)	4.1	8.3	10.2	11
Maximum of average load torque(N.m)	3.1	5.5	8.5	8.9
Max intermittent torque(N.m)	8.2	17	22	25
Backlash(Arcses)	≤20	≤20	≤20	≤10
Maximum input speed(r/min)	8500			
Average input speed(r/min)	3500			
Inertia(1/4GD)(g.cm ²)	1.4x10 ²			
Weight (g)	≤0.14kg			
Designed life	7000			
Efficiency in nominal torque(25 °C)	62%	65%	60%	60%
Harmonic drive gearbox model	AM-40XBC-30	AM-40XBC-50	AM-40XBC-80	AM-40XBC-100

		INPUT GEARBOX DATA Max gear hole "A" $\phi 5 \text{ h}7$ With 2-M3x4 GB/T77-2000 hexagon flat-end set screws	MOTOR DIMENSION
Recommend Motor: Coreless Motor (w/E) AM-CL35** AM-CL40**	Recommend Encoder: Suitable for Coreless Motor Encoder S: AM-EN2211S*** Encoder T: AM-EN2412T***	GEARBOX MOTOR LENGTH "LT"	
Brushless Motor (w/E) AM-BL36** AM-BL40**		Suitable for Brushless Motor Encoder S: AM-EN2211S*** Encoder T: AM-EN2412T***	
		Gear motor length L _T 112.7 Harmonic length L ₁ 31.5 Motor length L ₂ 70.5 Encoder length L ₃ 10.7	

Download datasheet: <https://assunmotor.com/documents-download>

Visit Our Website and Online Shop at <https://assunmotor.com> Contact: info@assunmotor.com