

AM-40HP Series

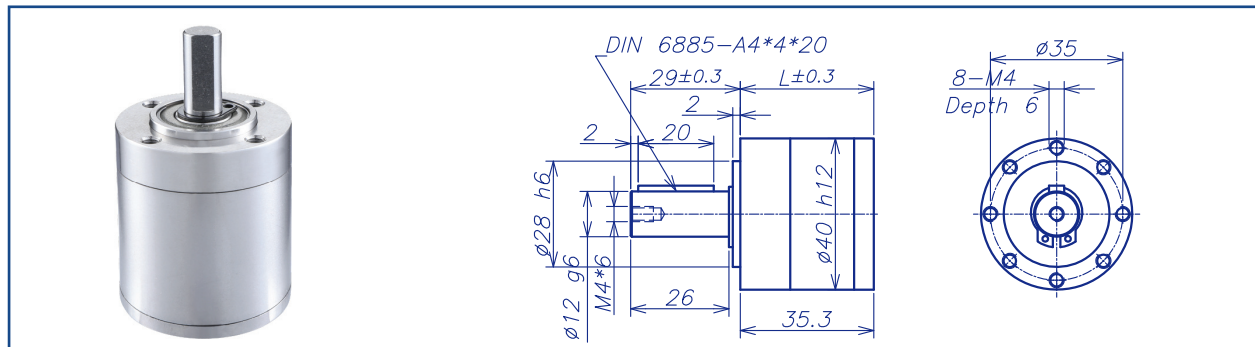

GEARBOX CHARACTER

Gear type	Straight teeth	Radial Play (10mm from flange)	max 0.1mm			
Output shaft	Stainless steel hardened	Permissible force press fits	max. 150 N			
Main gear	Alloy steel hardened	Permissible axial load (dynamic)	max. 150N			
Ring gear	Stainless steel hardened	Recommended input speed	10000RPM			
Adapter plate	Stainless steel	Operating temperature range	-40°C ~ +100°C			
Bearing AT output	Ball bearing	Operating humidity range	10-90%RH			
Axial play	0-0.3	Number of stages	1	2	3	4
Directions	CW/CCW	Permissible load (18mm from flange)	210N	310N	380N	380N

GEARBOX DATA

Number of stage	1			2		3			4			
Reduction ratio X:1	3.3	4	5.5	11	30	34	64	166	112	256	541	915
				13		42	72		137	286	666	
				16		52	88		169	320		
				18		58	98		189	352		
				22			121		208	393		
									232	484		
Reduction ratio absolute	13/4	4/1	11/2	169/16	121/4	2197/64	64/1	1331/8	28561/256	256/1	17303/32	14641/16
				13/1		169/4	143/2		2197/16	286/1	1331/2	
				16/1		52/1	88/1		169/1	20449/64		
				143/8		1859/32	1573/16		24167/128	352/1		
				22/1			121/1		208/1	1573/4		
									1859/8	484/1		
Motor shaft max. diameter (mm)	6	5		6	5		6	5		6		5
Gearbox length "L" (mm)	35.3			46.8		58.3			69.8			
Max. continuous torque (N.m)	3.5			7		14			15			
Max. intermittent torque (N.m)	5.25			10.5		21			22.5			
Average backlash no load	0.7°			0.8°		0.8°			0.8°			
Gearbox efficiency	90%			81%		73%			65%			
Max. mass inertia (g.cm ²)	8.14			8.58		8.62			8.63			
Gearbox weight approx (g)	320			420		520			620			
gearbox model	AM-40HPA-X			AM-40HPB-X		AM-40HPC-X			AM-40HPD-X			

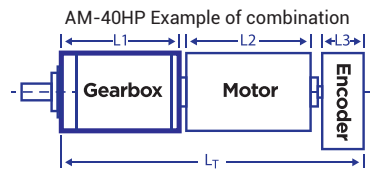

Recommend Motor:
Coreless Motor (w/E)
AM-CL3570GAN
AM-CL4071GAE

Brushless Motor (w/E)
AM-BL3660AN
AM-BL3675BF
AM-BL3690BF
AM-BL4060BF
AM-BD3660AN

Recommend Encoder:
Suitable for Coreless Motor
Encoder S: AM-EN2211S***
Encoder T: AM-EN2412T***

Suitable for Brushless Motor
Encoder S: AM-EN2211S***
Encoder T: AM-EN2412T***
AM-EN3612T***

INPUT GEARBOX DATA

Modulus	0.6		
Press angle	20°		
Teeth number	12	18	24
Max gear hole "A"	5	6	6
Max motor shaft	5	6	6
Motor dimension "D"	9.5	13	16

MOTOR DIMENSION

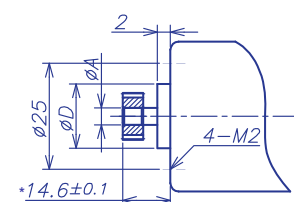

GEARBOX MOTOR LENGTH "LT"

Gear motor length L _T	127.5	129	141.8
Gear box length L ₁ *	46.8	58.3	69.8
Motor length L ₂	70	60	60
Encoder length L ₃	10.7	10.7	12

*Note: If combined with AM-CL3570, L₁=L+5mm, distance between gear and motor=14.6+5mm.

Download datasheet: <https://assunmotor.com/documents-download>

Visit Our Website and Online Shop at <https://assunmotor.com> Contact: info@assunmotor.com