

AM-22GP Series

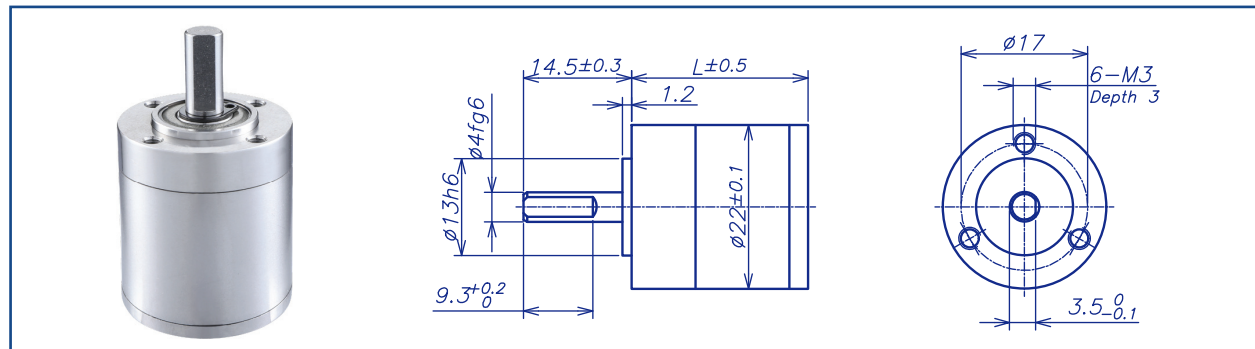

GEARBOX CHARACTER

Gear type	Straight teeth	Radial Play (8mm from flange)	max. 0.1mm
Output shaft	Stainless steel hardened	Permissible force press fits	max. 100 N
Main gear	Alloy Steel hardened	Permissible axial load (dynamic)	max. 40N
Ring gear	Stainless steel hardened	Recommended input speed	12000RPM
Adapter plate	Stainless steel	Operating temperature range	-40°C ~ +100°C
Bearing AT output	Ball bearing	Operating humidity range	10-90%RH
Axial play	0-0.3	Number of stages	1 2 3 4
Directions	CW/CCW	Permissible load (10mm from flange)	55N 75N 100N 100N

GEARBOX DATA

Number of stage	1			2			3			4		
Reduction ratio X:1	3.1	4.0	6.0	10	19	31	75	113	158	356	679	
				13	24	40	96	144	186	384	864	
				16	36	50		216	201	453	1296	
						59			237	576		
						64			256			
									302			
Reduction ratio absolute	22/7	4/1	6/1	484/49	132/7	10648/343	528/7	792/7	7744/49	17424/49	4752/7	
				88/7	24/1	1936/49	96/1	144/1	63888/343	384/1	864/1	
				16/1	36/1	352/7		216/1	1408/7	3168/7	1296/1	
						2904/49			11616/49	576/1		
						64/1			256/1			
									2112/7			
Motor shaft max. diameter (mm)	3	1.5	3	1.5	3	1.5	3	1.5	3	1.5	3	
Gearbox length "L" (mm)	18.9			23.7			28.5			33.3		
Max. continuous torque (N.m)	0.4			0.7			1.2			1.5		
Max. intermittent torque (N.m)	0.6			0.8			1.4			1.7		
Average backlash no load	1.1°			1.3°			1.3°			1.3°		
Gearbox efficiency	90%			81%			73%			65%		
Max. mass inertia (g.cm ²)	0.28			0.31			0.31			0.31		
Gearbox weight approx (g)	45			55			65			75		
gearbox model	AM-22GPA-X			AM-22GPB-X			AM-22GPC-X			AM-22GPD-X		

AM-22GP Example of combination

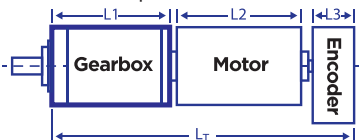

INPUT GEARBOX DATA

Modulus	0.4
Press angle	20°
Teeth number	9 15 21
Max gear hole "A"	1.5 3 3
Max motor shaft	1.5 3 3

MOTOR DIMENSION

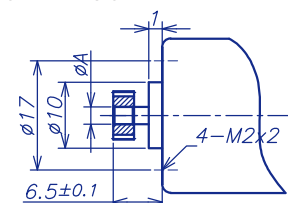

Recommend Motor:

Coreless Motor (w/E):
AM-CL16***
AM-CL19***
AM-CL22***

Brushless Motor (w/E):
AM-BL16***
AM-BL20***

Recommend Encoder:

Suitable for Coreless Motor
Encoder S: AM-EN1611S***
AM-EN2211S***

Suitable for Brushless Motor

Encoder S: AM-EN1611S***
Encoder T: AM-EN1612T***

GEARBOX MOTOR LENGTH "LT"

Gear motor length L_T	41.9	74.4	80.5
Gear box length L_1	18.9	23.7	28.5
Motor length L_2	23	40	40
Encoder length L_3	-	10.7	12

Download datasheet: <https://assunmotor.com/documents-download>

Visit Our Website and Online Shop at <https://assunmotor.com> Contact: info@assunmotor.com