

BS-FU26-6-D1E9

Fiber Optical Gyro

Specifications



Military Fiber Optic Gyro

- UAV/AUV/Helicopter
- Tactical nuclear weapons
- Aeronautics and astronautics
- Integrated navigation system
- Inertial platform stabilizing
- Vehicle navigation

Descriptions

BS-FU26-6-D1E9 is the interferometric digital close-loop single-axis fiber optic gyro. It is the perfect substitution for traditional mechanical gyro, featuring of high bandwidth, short activation time, shock resistance, vibration resistance and affordable cost.

The BS-FU26-6-D1E9 FOG adopt the embedded digital signal processor. The integrated adaptive filter reduces the bias stability and angle random walk by 50%-70%, technology which not only reduces the impact of the temperature but also significantly improves the bias stability, angle random walk, scale factor linearity and robustness. The exceptional bias stability, angle random walk and resistance to shock make it ideal for various military and industrial applications.

BS-FU26-6-D1E9 is a angular speed sensor integrated with light, mechanism and electricity. it is based on Sagnac effect and close loop control test technology. it tests, processes and feedbacks by the phase difference produced by two opposite transmission light, realizing the whole close loop process. the item is mainly composed by optical path units, circuit units and structural unit. it has simpler structure, no moving parts, no wearing parts, quicker start, smaller volume and lighter comparing with electromechanical gyro. It could be widely used in missile guidance and control, positioning and aiming system of tank and fighting vehicle, ship's photoelectrical tracking system

Features

- All-fiber design -long lifespan, small package size, high stability and more resistance to interference.
- Integrated fiber polarizer -minimum insertion loss and high extinction ratio, offering more resistance to temperature and mechanical shock, as well as intense vibration.
- Reliable compact package -operationally robust for all kinds of environments, ideal for a wide of applications in both civilian and military areas.
- QuickLaunch technology -minimum activation time with no external calibration required.
- Optimal wavelength -improves the sensibility by 50% with the same structure, size and cost.
- Noise isolation and compression -significantly reduces the angle random walk.
- SelfTrack technology -improves the gyro dynamic range

Applications

- UAV/AUV/Helicopter ● Tactical nuclear weapons ● Aeronautics and astronautics
- Integrated navigation system ● inertial platform stabilizing ● Vehicle navigation



Components inside

- a) Optical components: Fiber optic ring、Y waveguider、Coupler、SLD light、PIN-FET detector;
- b) The source of light drive circuit, Detection and signal control circuit board;
- c) Fiber optic ring frame、Outcover、Topcover、Bottom plate;

Performance Characteristics

No.	Parameter	BS-FU26-6-D1E9	Unit	Remarks
1	Maximum angular rate	±600	°/s	
2	Scale factor	45000x (1±10%)	SP/°/s	
3	Scale factor nonlinearity in room temperature	≤50	ppm	@25°C
4	Scale factor repeatability in room temperature	≤50	ppm	@25°C
5	Scale factor repeatability in full temperature	≤150	ppm	-40°C~+70°C
6	Bias stability in room temperature	≤0.1	10s 1σ, °/h	@25°C
7	Bias repeatability in room temperature	≤0.1	1σ, °/h	Bias
8	Bias repeatability in tull temperature	≤0.3	1σ, °/h	-40°C~+70°C
9	Activation time	0	min	
10	Bias value during vibration/before vibration/after vibration	≤0.5	°/h	
11	Bias value before/after vibration)	≤0.5	°/h	

12	Magnetic sensitivity		≤ 0.3	$^{\circ}/h/Gs$	Optional
13	Vibration	20Hz~2000Hz			Hz/10min
		X	Y	Z	
13	Vibration spectrum				
14	Impact	15g(3times)			Half sine wave/11ms
		$\pm X$	$\pm Y$	$\pm Z$	

Environment requirement

Power supply	+5V	
The fluctuation of voltage	4.75V~5.25V	-4.75V~-5.25V
Rated ripple voltage	20mV	20mV
Power consumption	1.5A	0.6A

Interface definition

DB9 Connector Definition

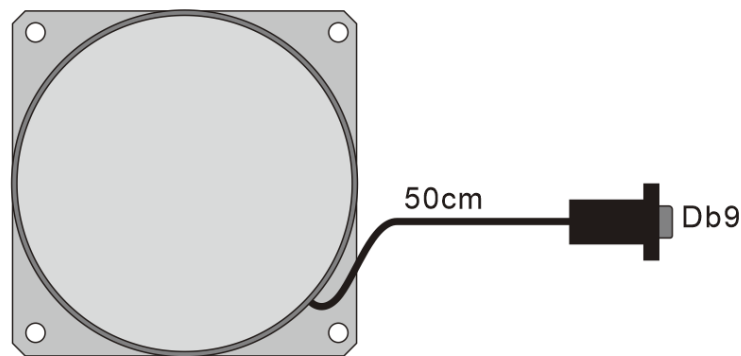

No.	Definition	noted
1	+5V	Power input
2	GND	Power GND
3	--	NC
4	RXD+	Data output

No.	Definition	noted
5	TXD+	Data output
6	+5V	Power input
7	GND	Power GND
8	RXD-	Data output
9	TXD-	Data output

Dimensions

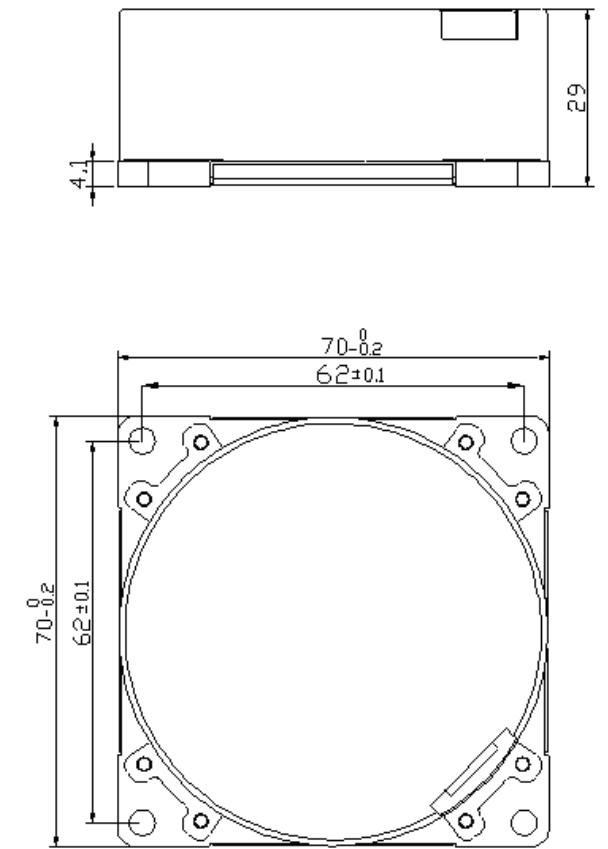

Gyro communication protocol

- 1) Input synchronous square wave: gyro receive external 400Hz square wave through RS422, synchronization time is positive pulse falling edge synchronization
- 2) Canbus type: RS422
- 3) Baudrate:460,800 bps
- 4) Data refresh rate: 2000Hz
- 5) Each byte has 11 bits, Include: 1 is start bit(0), 2~9is data bits, 10 is parity check bit, 11 is stop bit;
- 6) One frame data include gyro and temperature output value, The valid data for gyro is 32bits,The valid data for temperature is 12bits(The high bit is sign bit, 0 is positive,1 is negative)
- 7) Interface definition: see table below:

Package header	1	0	0	0	0	0	0	0
1 byte	0	D6	D5	D4	D3	D2	D1	D0
2 byte	0	D13	D12	D11	D10	D9	D8	D7
3 byte	0	D20	D19	D18	D17	D16	D15	D14
4 byte	0	D27	D26	D25	D24	D23	D22	D21
5 byte	0	0	0	0	D31	D30	D29	D28
6 byte	0	X	X	X	X	X	X	X
Note:the bytes was check byte,It is the XOR value from 1byte to 5byte.								
7 byte	0	D6	D5	D4	D3	D2	D1	D0
8 byte	0	D13	D12	D11	D10	D9	D8	D7
9 byte	0	X	X	X	X	X	X	X
Note:the bytes was check byte,It is the XOR value from 7byte to 9byte.								

Note on installation

Please avoid impact during installation, and no machining work on its surface is allowed.

Check before installation:

- a) check if there is physical damage on the product
- b) Under ordinary temperature, use insulation resistance meter test the insulation resistance between all pins of output interface and its shell, should $\geq 60M\Omega$
- c) Test all technical parameters when necessary
- d) The flatness of installation surface against the product should be better than 0.05mm
- e) When installation, 0.2~0.5mm layer of heat conducting silica gel is required to be coated under the bottom of the product
- f) Check if all screws are fixed steadily after installation

Product maintenance

- a) Before loading into the carrier, it is required to electrify the product one time at least every year, and the power one time is 3600s, and the electrical parameters of the product are not required to be detected when the power is switched on;
- b) After the product is loaded into the carrier, it is required to electrify the product one time at least every year, and the power one time is 3600s, and the electrical parameters of the product are not required to be detected when the power is switched on;
- c) Products should be re calibrated every 8 years.

Common fault phenomena and troubleshooting methods

- a) This product is in the state of full seal, and can not be repaired on the spot after any fault occurs at the user's sides, and needs to be returned to the product manufacturer for repair.

b) Here below are only a list of possible failures of the non - product itself, see table 5. If there are other technical problems occurs during using of products, please the user to contact the products manufacturer.

(Common fault and resolvent)

Item	Fault phenomena	Reason analysis	Resolvent
1	Product electrify, +5V、-5V ,the current indicator of the ammeter is basically 0	No power supply or current supply is too small for the product	Check the power supply and power supply circuit to restore the power supply
2	Product electrify, +5V、-5Vthe ammeter current is normal, but the computer acquisition program doesn't work	The acquisition system of test equipment unusual	Check the connection cable, equipment power supply situation
		Software program conflict	Restart the test computer
3	Product electrify, +5V、-5V the current indicator of the ammeter is abnormal	A short circuit may occur inside the test equipment	Inspection and test equipment

Requirements for transportation and storage of products

1 Transportation notice

- a) Place the product according to the direction shown in the packing box;
- b) When the temperature range is -40°C ~ +65°C, it is allowed to be transported by road, railway, air and water transportation;
- c) Ensure that the packing box is fastened to the carrier without moving during shipment。

2 Storage notice

- a) The products placed in the packing box should be stored in an air conditioned warehouse under standard atmospheric pressure, environmental temperature is 15°C ~ 35°C;
- b) The storage period of the product is 15 years 。

Unpacking and inspection

1 Unpacking inspection

- a) Check the appearance of the packing box for collision and other physical damage;
- b) Static electricity protection should be carried out when taking out the product 。

2 Inspection of supporting delivery documents

- a) Product qualification certificate;
- b) BS-FU26-6-D1E9 Acceptance report of closed loop fiber optic gyroscope;
- c) BS-FU26-6-D1E9 Maintenance instructions for closed-loop fiber optic gyroscope (1pcs per batch) 。